



ATD-WB Wheel Balancer Installation and Operation Manual



Features:

- Large Rim Diameter Balancing up to 24" Rim diameter & 39" overall Wheel Diameter
- LED, touch-panel Keypad with easy to read icons
- Multi-Mode Vehicle Balancing for Car & Motorcycle
- Manual Measurement Input for Distance & Diameter
- Static / Dynamic & 3 ALU balancing methods
- Self-Calibrating & Self Diagnostic
- Multi-User Operation
- Integrated Centering Spring for Balancing Shaft
- Pegs for Accessories
- Included: Hood, Hammer, Caliper, Cone Sets (small, medium, large & extra large), Bowl Clamps, Calibration Weight, Large Indicator & Speed Nut

CONTENTS

1	Introduction	P	3
2	Intended Use	P	3
3	General Safety Rules	P	3
	3.1 Safety Devices	P	4
4	Transport and Handling	P	4
5	Unpacking	P	5
6	Installation and Commissioning	P	5
	6.1 Electrical Connection	P	5
7	Installation	P	6
8	Use Suspension	P	7
9	Environmental Information	P	7
10	Ordinary Maintenance	P	8
11	Configuration	P	9
12	Display Panel & Control Panel	P	10
13	Mounting the Wheel	P	12
	13.1 Wheel Positive Position	P	12
	13.2 Wheel Negative Position	P	12
	13.3 Flange Disc Positioning (Optional)	P	13
14	Input Machine Three Parameters	P	13
	14.1 Input DIS (Distance) Value	P	13
	14.2 Input BR (Rim Breadth) Value	P	13
	14.3 Input DIA (Diameter) Value	P	13
15	Unit Conversion Button	P	14
16	Start Button	P	14
17	Display Imbalance Value	P	14
18	Residual Imbalance Value Display	P	15
19	Balance Mode Selection	P	15
20	Program Function Introductions	P	16
21	Factory Settings	P	17
22	Factory Calibration	P	18
23	Appendix	P	19
	23.1 Appendix 1 Layout of Power Supply Board	P	19
	23.2 Appendix 2 Wiring Diagram	P	20
	23.3. Appendix 3 Protection Cover Installation	P	21
24	Fire Protection Equipment to be Used	P	22
25	Error Indication	P	22
	Limited Warranty	P	23

1. INTRODUCTION

This manual is an integral part of the machine and has to stay with it until it is taken out of service.

Read carefully each section of this manual before using the machine. The manufacturer is not responsible for any damage and/or injury caused by failure to follow the instructions in this manual.

We also recommend:

- Keeping the manual near the wheel balancer for easy access
- Keeping the manual in a place protected from dirt
- Not damaging the manual.

In the manual the following symbols are represented:



Indicates operations that require special attention



Indicates prohibitions



Indicates possible danger for the operator

2. INTENDED USE

This manual is an integral part of the product.

Carefully read the warnings and instructions contained in this manual as they provide important information about SAFE USE and MAINTENANCE.



KEEP THIS HANDBOOK NEAR THE MACHINE FOR CONSULTATION BY THE OPERATOR

This wheel balancer has been made to balance wheels for automobiles, light trucks and SUV's (CAR) and Motorcycles (MOT). This machine works on wheels with diameters from 10" to 24" (254 to 610mm) and widths from 1.5" to 20" (38 to 508mm). All functions and controls can be set with the keys on the control panel and the data is displayed on the LED display.

3. GENERAL SAFETY RULES

The wheel balancer must be used exclusively for the purpose for which it has been designed.

Any other use is considered INCORRECT and UNREASONABLE.

The wheel balancer may be used by authorized, trained personnel only.

Do not put any objects in the base which may affect the correct operation of the wheel balancer.



THE MANUFACTURER IS NOT RESPONSIBLE FOR ANY DAMAGE TO PEOPLE OR PROPERTY CAUSED BY UNAUTHORIZED PERSONNEL OR IMPROPER, INCORRECT AND UNREASONABLE USE OF THE WHEEL BALANCER.



THE WHEEL BALANCER SHOULD NOT BE MODIFIED OR TAMPERED WITH WITHOUT THE MANUFACTURER'S PERMISSION. ANY UNAUTHORIZED CHANGE MADE TO THE EQUIPMENT RELIEVES THE MANUFACTURER FROM ANY LIABILITY IN CASE OF DAMAGE ATTRIBUTABLE TO SUCH ALTERATIONS.

3.1 Safety Devices

The machine is equipped with the following safety device: Rotation STOP button.

It is forbidden to tamper with, bypass or remove the safety devices installed, this being a violation of the safety regulations.



REMOVING OR TAMPERING WITH SAFETY DEVICES ENTAILS A VIOLATION OF THE SAFETY DIRECTIVES, VOIDS WARRANTY AND IS DANGEROUS TO THE USER. IT COULD RESULT IN IN PERSONAL INJURY OR DEATH.

4. TRANSPORT AND HANDLING

The wheel balancer is packed in a carton box on a pallet.

Transport and handling must be carried out BY AUTHORIZED PERSONNEL ONLY, using a pallet truck or forklift and adopting appropriate safety measures.

If the machine is not packed, take the following precautions:



PROTECT SHARP EDGES AT THE ENDS WITH SUITABLE MATERIAL (bubble wrap or cardboard).



DO NOT USE METAL WIRE ROPES FOR LIFTING.



SLING WITH STRAPS OF AT LEAST 79" (200 cm) IN LENGTH AND WITH A GREATER CAPACITY THAN 6,600 lbs. (3000 kg)



DO NOT USE FORCE ON THE SHAFT AND/OR FLANGE



ALWAYS UNPLUG THE POWER CORD FROM THE SOCKET BEFORE MOVING THE MACHINE.

The environmental working conditions must comply with the following requirements:

- Temperature from 32°F to 113°F (0° C to + 45° C)
- Relative humidity from 20% to 95%

5. UNPACKING

After removing the packaging, check the integrity of the machine making sure there are no visibly damaged parts.

In case of doubt, DO NOT USE THE MACHINE and consult professionally qualified personnel (dealer or manufacturer). The packaging materials (plastic bags, expanded polystyrene, nails, screws, pieces of wood, etc.) must not be left within reach of children as they are potentially dangerous. Take the packaging materials to appropriate collection centers.



MAKE SURE YOU HAVE NOT THROWN AWAY THE ACCESSORY BOX WITH THE PACKAGING.

6. INSTALLATION AND COMMISSIONING

After unpacking the various parts of the wheel balancer, ensure they are intact and check for any anomalies, then assemble the parts.

6.1 Electrical Connection

The standard version of the machine must be connected to a 110V, 60HZ, SINGLE PHASE power supply. To complete the electrical connection, install the plug provided to the machines power supply cable.



ALL THE OPERATIONS REQUIRED TO MAKE THE ELECTRICAL CONNECTION AND ANY WORK (HOWEVER SLIGHT) ON THE ELECTRICAL PARTS MUST BE CARRIED OUT BY QUALIFIED PERSONNEL.

Electrical cables must be sized according to the electrical power used by the machine. The user must:

- Check that the supply voltage corresponds to the voltage indicated on the nameplate of the machine.
- Check the condition of wires and the presence of the ground conductor.
- Check that the machine is connected to its own circuit, fitted with a 30A circuit breaker
- Connect the power supply cable to the plug with the utmost care, in accordance with applicable regulations.



WHEN THE MACHINE IS OFF AND UNUSED FOR LONG PERIODS, IT IS NECESSARY TO DISCONNECT THE POWER SUPPLY PLUG TO PREVENT USE BY UNAUTHORIZED PERSONNEL.



IF THE CONNECTION TO THE ELECTRICAL LINE OCCURS DIRECTLY THROUGH THE ELECTRICAL PANEL, WITHOUT THE USE OF ANY PLUG, IT IS NECESSARY TO SET UP A KEY SWITCH TO RESTRICT THE MACHINE USE EXCLUSIVELY TO QUALIFIED PERSONNEL.



IN CASE OF OPERATIONS ON LINES, MOTOR INTERNAL PARTS OR ANY ELECTRIC EQUIPMENT, IT IS NECESSARY TO DISCONNECT FROM MAIN POWER FIRST.



DO NOT REMOVE OR DAMAGE WARNING, INSTRUCTION AND CAUTION STICKERS ILLEGIBLE. REMOVED OR DAMAGED STICKERS CAN BE OBTAINED THROUGH YOUR DISTRIBUTOR.



ANY DAMAGE RESULTING FROM FAILURE TO COMPLY WITH THE ABOVE INSTRUCTIONS WILL NOT BE CHARGED TO THE MANUFACTURER AND MAY INVALIDATE THE WARRANTY.

7. INSTALLATION

To install the machine you must have 24" (600 mm) of space from each side of the machine, as shown in FIG. 004. Total footprint of this wheel balancer is 102" wide x 85" deep.

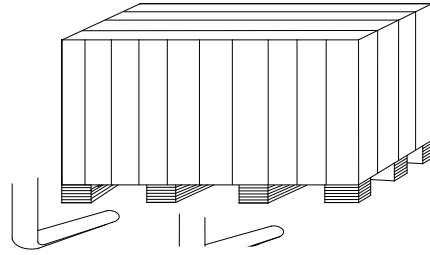

FIG. 001

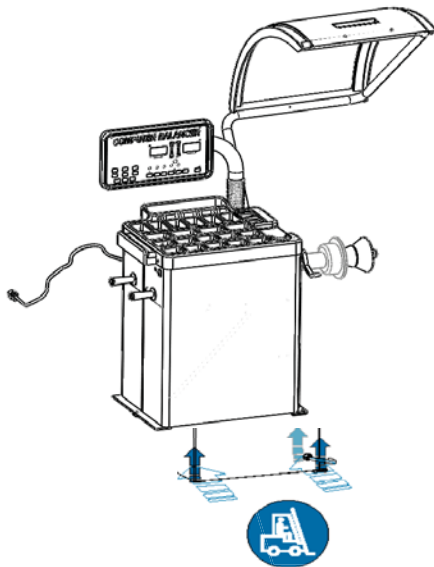

FIG. 002

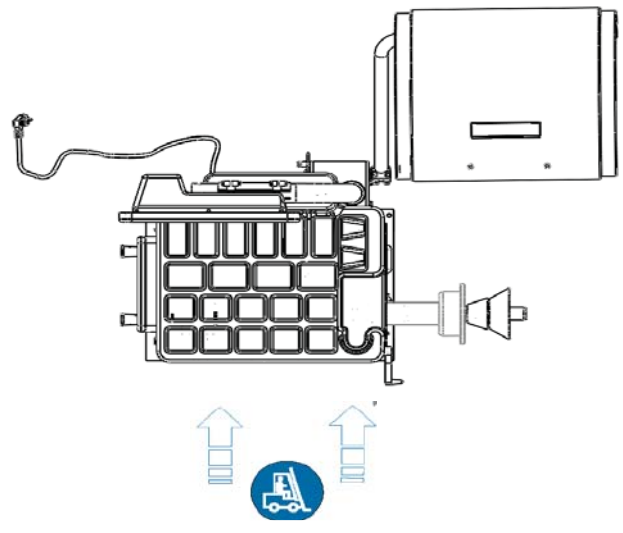

FIG. 003

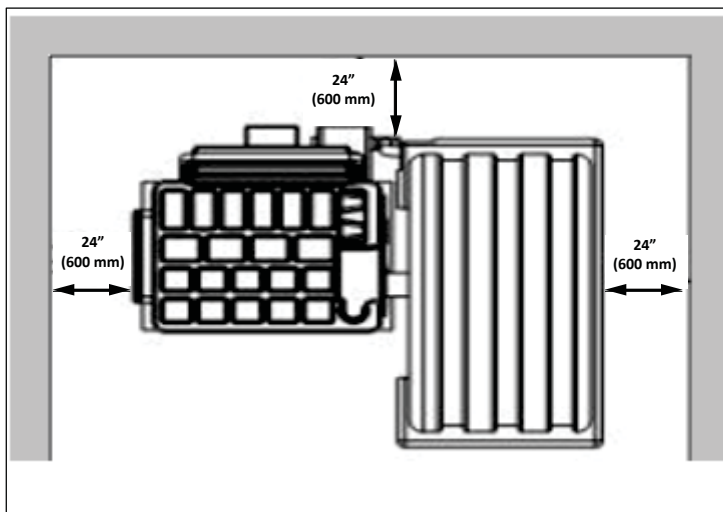

FIG. 004



FIG. 005

Threaded shaft Installation:

Before installation, use ethyl alcohol and compressed air to clean up the center hole of the shaft and connector. Use hex wrench and screw to attach the threaded shaft to the balance shaft (FIG. 005)

From the workarea, the user must be able to see the machine and the surrounding area.



THE INSTALLATION AREA MUST BE KEPT CLEAR OF ANY DANGEROUS OBJECTS.



UNAUTHORIZED PERSONNEL MUST NOT STAND IN THE WORK AND INSTALLATION AREAS.



THE MACHINE MUST BE PLACED ON A HORIZONTAL, PREFERABLY A CONCRETE FLOOR.



AVOID BREAKABLE SURFACES SUCH AS CERAMIC TILE AND ROUGH SURFACES SUCH AS GRAVEL.



THE SURFACE MUST WITHSTAND THE LOADS TRANSMITTED DURING OPERATION.



THE MACHINE MUST BE ELECTRICALLY GROUNDED.



THE MACHINE MAY BE ONLY USED IN PLACES THAT DO NOT POSE ANY EXPLOSION OR FIRE HAZARDS.

8. USE SUSPENSION

Should the machine not be used for long periods, disconnect the power supply and protect all parts that could be damaged by dust. Grease all parts that could be damaged in case of oxidation. In this specific case, protect the shaft and flange.

9. ENVIRONMENTAL INFORMATION



THE DISPOSAL PROCEDURE DESCRIBED BELOW ONLY APPLIES TO MACHINES WITH THE SYMBOL OF THE CROSSED-OUT WHEELIE BIN ON THEIR DATA PLATES.



The crossed-out trash bin symbol, placed on the product and on this page, reminds the user that the product must be disposed of properly at the end of its life. This product may contain substances that can be hazardous to the environment and to human health if it is not disposed of properly. We are therefore providing you with the information below in order to prevent these substances from being released into the environment, and to improve the use of natural resources. Electrical and electronic equipment must never be disposed of in the usual municipal waste but must be separately collected for proper treatment. Thus, the hazardous consequences that non-specific treatments of the substances contained in these products, or improper use of parts of them, may have on the environment or on human health are prevented. Furthermore, this helps to recover, recycle and reuse many of the materials contained in these products. For this purpose, electrical and electronic manufacturers and distributors set up proper collection and treatment systems for these products. At the end of the product service life, contact your local recycler for information about disposal procedures.

Any disposal of the product performed in a different way from that described above will be liable to the penalties provided for by the local regulations in force in your community.

We also ask you to adopt other environmentally-friendly measures: recycle the internal and external packaging that the product comes in, and suitably dispose of used batteries (only if contained in the product).

Your help is critical to reduce the amount of natural resources used for manufacturing electrical and electronic equipment, minimise the use of landfills for product disposal and improve the quality of life, preventing potentially hazardous substances from being released into the environment.

10. ORDINARY MAINTENANCE

To ensure the efficiency and proper operation of the machine, it is essential to follow the manufacturer's instructions by performing periodic cleaning and routine maintenance.



CLEANING AND ORDINARY MAINTENANCE MUST BE PERFORMED BY AUTHORIZED PERSONNEL IN ACCORDANCE WITH THE MANUFACTURER'S INSTRUCTIONS PROVIDED BELOW.

Always keep the flanges clean (do not lubricate them). In addition, during handling, be very careful not to damage them. To clean the machine, especially the weight tray, use a soft cloth moistened with ethyl alcohol.



BEFORE PERFORMING ANY REPAIRS, DISCONNECT THE POWER SUPPLY CABLE FROM THE SOCKET.



**DO NOT USE COMPRESSED AIR TO CLEAN THE MACHINE.
DO NOT USE WATER OR LIQUIDS OTHER THAN ETHYL ALCOHOL TO CLEAN THE MACHINE.**

11. CONFIGURATION

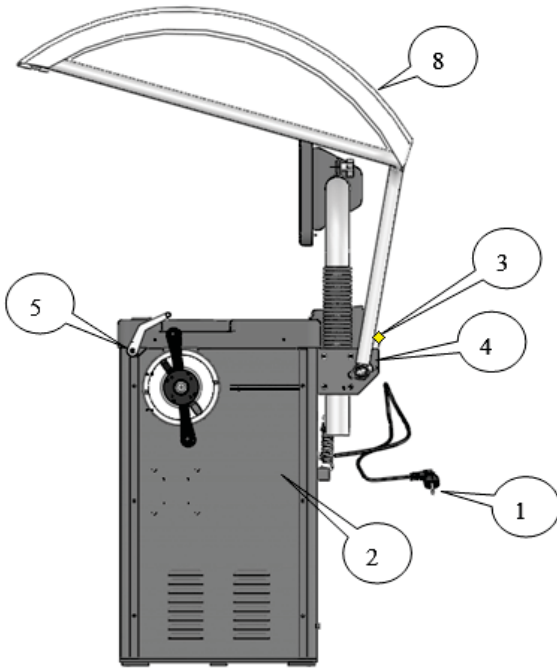

FIG. 006

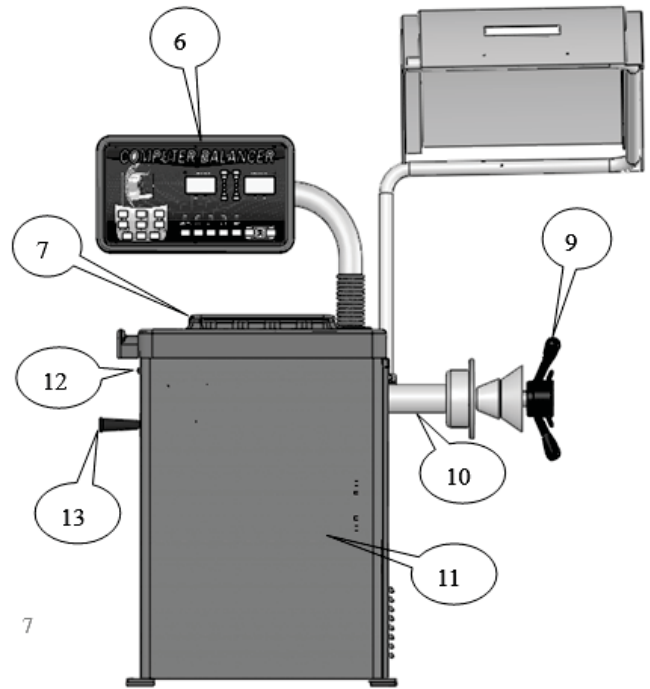

FIG. 007

- 1- Power Cable & Plug
- 2- Side Panel
- 3- Hood Return Spring
- 4- Magnetic Hood Switch
- 5- Scale
- 6- Control Panel
- 7- Weight Tray
- 8- Hood
- 9- Quick Nut
- 10- Balance Shaft
- 11- Body
- 12- Power Switch
- 13- Cone Storage Handle

12. CONTROL PANEL

The machine control panel is shown in FIG.008. The control panel allows the operator to give commands and enter or edit data. The same control panel displays the machine balancing results and messages.

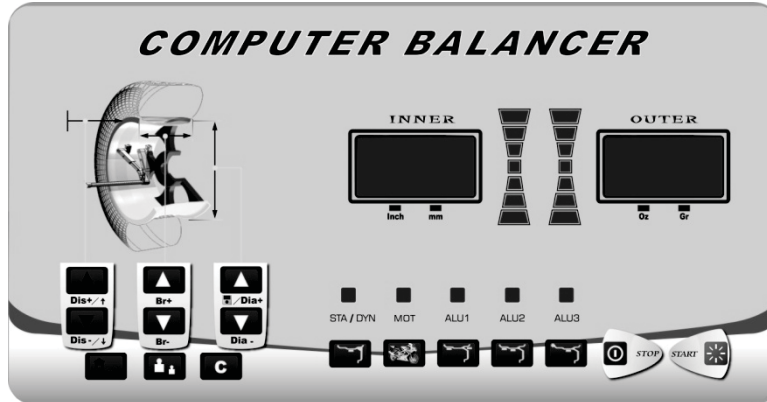

FIG.008



Dis+ / ↑

1. This parameter input, is the distance from wheel to balancer input key .You can change the distance set value by pressing the up/down key.



Dis- / ↓



Br+

2. Br value input key. You can change the Br set value by pressing the up/down key.



Br-



□ / Dia+

3. This parameter input, it is the diameter input key. You can change the diameter set value by pressing the up/down key.



Dia -



4. High accuracy balance key: When the display displays [000], press this key and the display will display the unbalance value less than 0.25 Oz.



5. Unit conversion key can convert the unit of measure for the unbalance, size and weight values.



6. Balancing mode selection keys.



7. Function & confirm key (Home Key)



8. Emergency Stop Key.



9. Start Key.

INNER



10. Inner unbalance value and parameter display.

OUTER



11. Outside imbalance value and parameter display

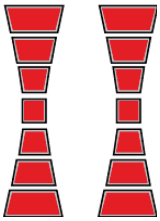

12. Unbalance position indicator.



13. Balancing modes display lamp

13. MOUNT THE WHEEL

Preparation before balancing. Check for and clean any dirt, mud and debris embedded in the tire and treads, and also check that the air pressure of the tire is to specifications. Check for deformations on the rim surface and mounting holes. Remove the original wheel weights.

Installation methods of the wheel are positive positioning, negative positioning and flange disc positioning. You can select the method of mounting according to the different conditions and sizes.

13.1 Wheel Positive Position

Positive positioning is the most common method. It is simple and quick, and is mainly suitable to common steel rims and aluminum alloy rims with small imperfections.

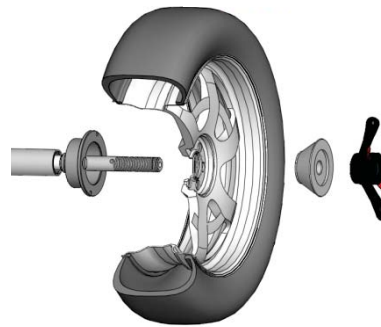

Main shaft → wheel → cone → quick nut

13.2 Wheel Negative Position

When there are imperfections on the outside of the wheel, use this method of positioning to guarantee the accurate positioning of the steel rims inner hole on the main shaft. It is used on steel rims and thicker aluminum rims.



Main shaft → suitable cone → wheel → bowl → quick nut

13.3 Flange Disk Positioning (Optional)

Used on tire assemblies with large center holes in the rim.

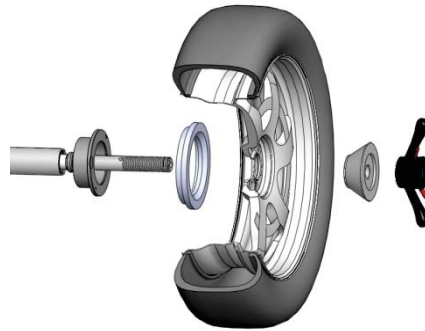

Main shaft → flange disk (fixed on the main shaft) wheel → cone → quick nut

NOTE: The choice of the cone should be dependant on the rim center hole. Pay attention to it's direction, or it will cause an inaccurate measurement.

14. INPUT MACHINE THREE PARAMETERS

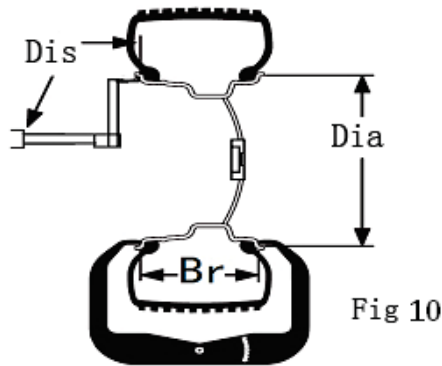

14.1 Input DIS (Distance) Value



Pull the scale to the inner position to add the weight and press the key **Dis+ / ↑** **Dis- / ↓** to input the DIS value into the display. Once inputed, the display will show [DIS]: [XXX], the default system is mm.

14.2 Input Br (RIM Breadth) Value



Use the Br measurement caliper to measure the Br of the rim, press the key **Br+ / ↑** **Br- / ↓** to input the Br value into the display. Once inputed, the display will display [Br.]: [XXX], the default system is inch.

14.3 Input the DIA (Diameter) Value



After confirming the rim diameter, press the key **DIA+ / ↑** **DIA- / ↓** to input the rim diameter into the display. Once inputed, the display will display [Dia]: [XXX], the default system is mm.



① The unit conversion of the Br of the rim from inch to mm:

Normally, the display of Br should be in inch. When you need the unit of the display to be mm, you can use the



② The unit conversion of the DIA of the rim from inch to mm:

Normally, the display of DIA should be in inch. When you need the unit of the display to be mm, you can use the



After unit conversion, the unit will display values of rim Br and DIA value, but when you switch the wheel balancer off wheel balancer, the unit will be still inch.



③ The unit conversion from gram to ounce:

Normally, the unit of the unbalance value is gram (g). If you want to measure in ounces (Oz), you can execute the g/Oz conversion. The unit of the displayed unbalance value is gram(g). The way to convert from gram to ounce is to press



16. START BUTTON

When you press the start key the wheel balancer starts to run. A few seconds later, the machine automatically stops. The machine can also be programmed to start by lowering down the protective hood.



Unbalance Position Indicator

17. DISPLAY IMBALANCE VALUE

INNER



OUTER



When the spin ends, the display will show the inner and outer unbalance value of the rim. Use your hand to spin the wheel. When all of the inside and outside lights on the unbalance position indicator light up, the position to add weight will be indicated. Rotate the wheel. When the left side positioning lamps all light up, the highest position is the inner unbalance position and when the right side positioning lamp all light, at this moment, the highest position is the outer unbalance position. Add the corresponding weight at the unbalance point and start the test again until the balance of the tire is achieved.







1. When starting the machine, use hand to spin the wheel to help it start rotation, especially with larger tires. This will prolong the working life of the motor.
2. Confirm tire dimensions. Check that the balance methods meet the configuration of the rim and select the method most easily to balance.
3. Confirm that the quick lock nut is tight.
4. When the balancing process ends, remove the tire. Pay attention to handle it with care and avoid knocking the shaft.
5. When trimming the weight, use the hammer to trim the weight on the rim gently, without too much force. Do not knock the main shaft too hard to avoid damaging the sensor. The position to add the weight should be free from grease and should be dry.

18 RESIDUAL IMBALANCE VALUE DISPLAY

The minimum value of the standard weight is 5g so if the weight you use is less than 5g, the wheel balancer will not display the value and only displays the state of "00". When you need to display the residual unbalance value, you should press  key and the display will immediately display the inside or outside unbalance value of less than 5g. The maximum residual unbalance value is 4g.

19. BALANCE MODE SELECTIONS

Press the corresponding      key to choose the balance mode. If all the lights do not light up, it is in dynamic mode.



DYNAMIC— Clip the weights on both sides of rim.



STATIC— Stick the weight in the center.



MOT— Option for balancing motorcycle rims.

When balancing motorcycle wheels, you will require the (optional) motorcycle adaptor accessory MJ-II. With the assistance of the extension scale to measure distance, Br and diameter value. Input the value into the Di, Br and Di display window. The input method is the same as the parameter input of the car



ALU1— To balance light aluminium alloy rims, stick the weight on the shoulders of the rim.

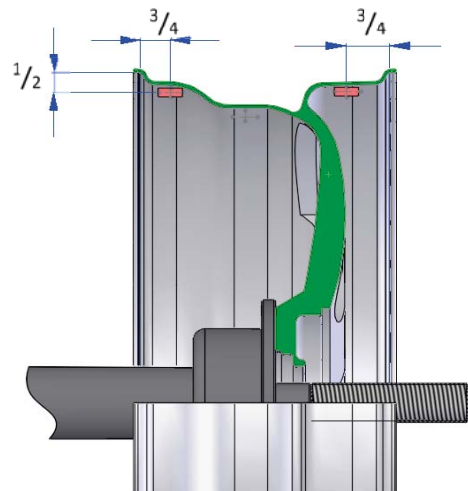

ALU1



ALU2— For aluminum rim, hidden weight inside

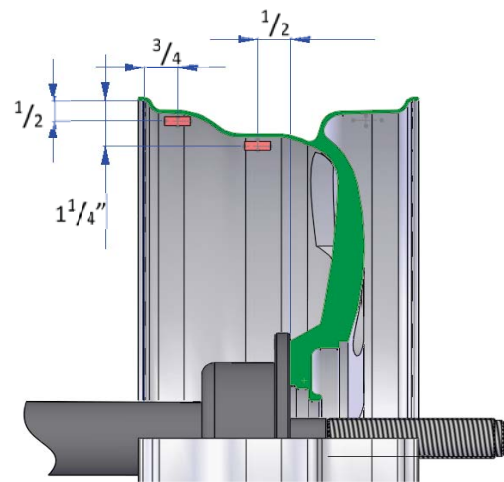

ALU2



ALU3—Clip the weight inside, the position to add weight outside is the same as ALU2.

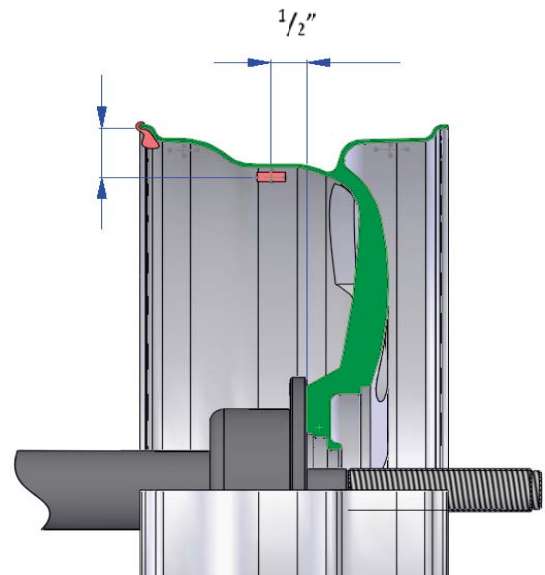

ALU3

20. PROGRAM FUNCTION INTRODUCTIONS

➤ Change from .1 Oz to .25 Oz (Ounce / Oz)

- Press Home Key
- Press DIS - twice
- Press Home Key
- Left Right
- APP .1 Oz
- Want .25 Oz
- Press DIS +
- Left Right
- APP .25 Oz
- Press Home Key
- Press DIA +

➤ **Change from 1g to 5g (Gram / g)**

- Press Home Key
- Press DIS – twice
- Press Home Key
- Left Right
- APP 1g
- Want 5g
- Press DIS +
- Left Right
- APP 5g
- Press Home Key
- Press DIA +

21. FACTORY SETTINGS

➤ **Turn machine on**



➤ **Press the following sequence of buttons to do a Factory Reset**



- Press Home Key
- Press DIS +
- “Setup” appears
- Press Home Key 2 Times
- Below appears
- Left Right
- “POS” “###”
- Rotate shaft until “111” appears in right window
- Press C
- Rotate shaft until “55” appears in right window
- Press C
- Rotate shaft until “111” appears in right window
- Press C
- Below appears
- Left Right
- “COD” “Set”
- Press Home Key
- Below appears
- Left Right
- “###” “###”
- Press DIS + until “46” appears in the left window
- Press Home Key
- Below appears
- Left Right
- “B-A” “###”
- Pull Distance Gauge out and put to Flange – note distance on distance gauge
- The number on the right must match the number noted on distance gauge

- Change the number on the right by pressing DIS + or DIS –
- Press Home Key
- Below appears
- Left Right
- “EL1” “###”
- Use DIS + or DIS – to change the number on the right to 007
- Press Home Key
- Press Home Key
- Until the reset is completed with a series of beeps
- Turn the machine off and back on

22. FACTORY CALIBRATION

Below you would find the detailed instructions:

Press “Home key” one time , and it displays “[P]”, press “DIS + button” one time  , and you will see “[SET]-[UP]”

Press “Home key” two times , and it displays [POS—XXX], spin the wheel by hand (clock-wise or counter-clock-wise) slowly. When it displays [POS]—[110] press the “High Accuracy Balance Key” one time , then continue to spin the wheel slowly until it displays [POS]—[120] Press “High Accuracy Balance Key” one time. 

The screen displays [ADD]-[0], press  or lower down the hood to start rotation of the machine.

When machine stops rotation, it displays [ADD]—[100] , At this time, spin the wheel until the outer indicating lights are all illuminated, clamp 100g /3.5 Oz calibration standard weight on the outside rim at 12 o’clock position. Press  or lower down the hood to start rotation of the machine.

When the machine stops, it displays “100—ADD”. At this time, remove that 100g /3.5 Oz standard weight from the outside rim edge first, then spin the wheel by hand until the inner indicating lights are all illuminated, clamp that 100g / 3.5 Oz standard weight on the inside rim at 12 o’clock position, press  or lower down the hood to start the rotation again. When it stops, you will hear 3 times beeps indication and the factory calibration is over.

23. APPENDIX

23.1 Appendix 1 - Layout of the Power Supply Card

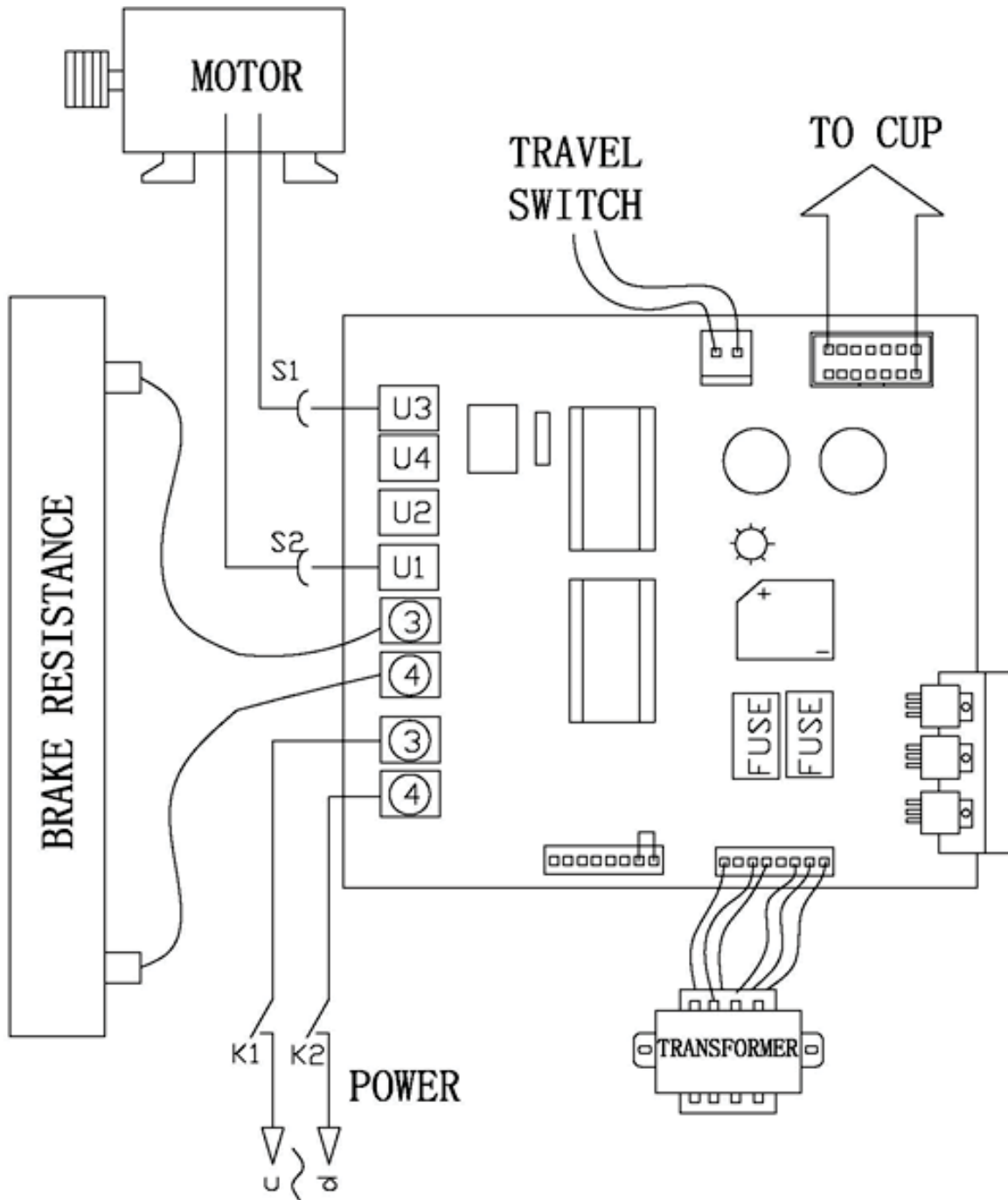

23.2 Appendix 2 - Wiring Diagram

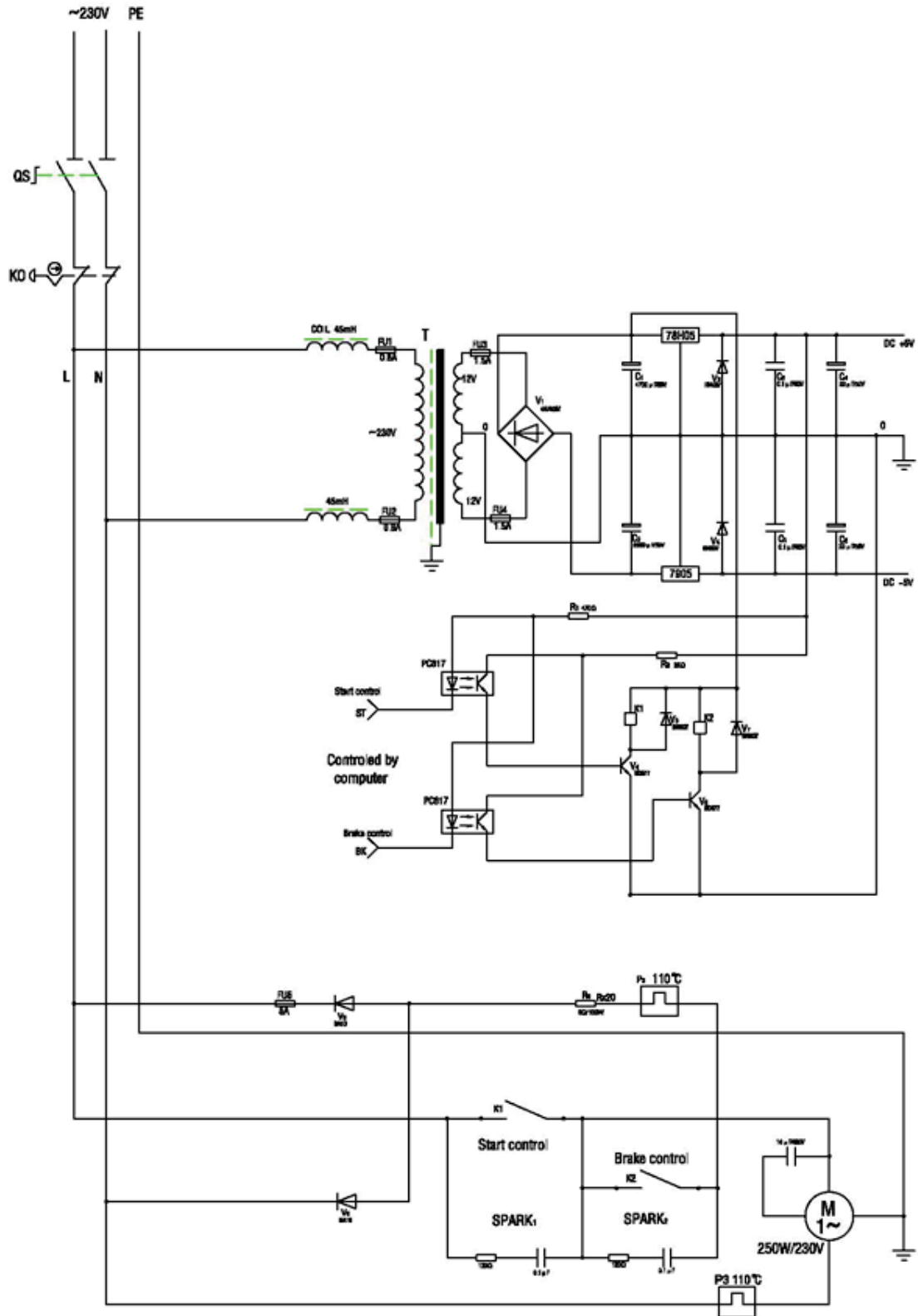

23.3 Appendix 3 - Protective Hood Cover Installation

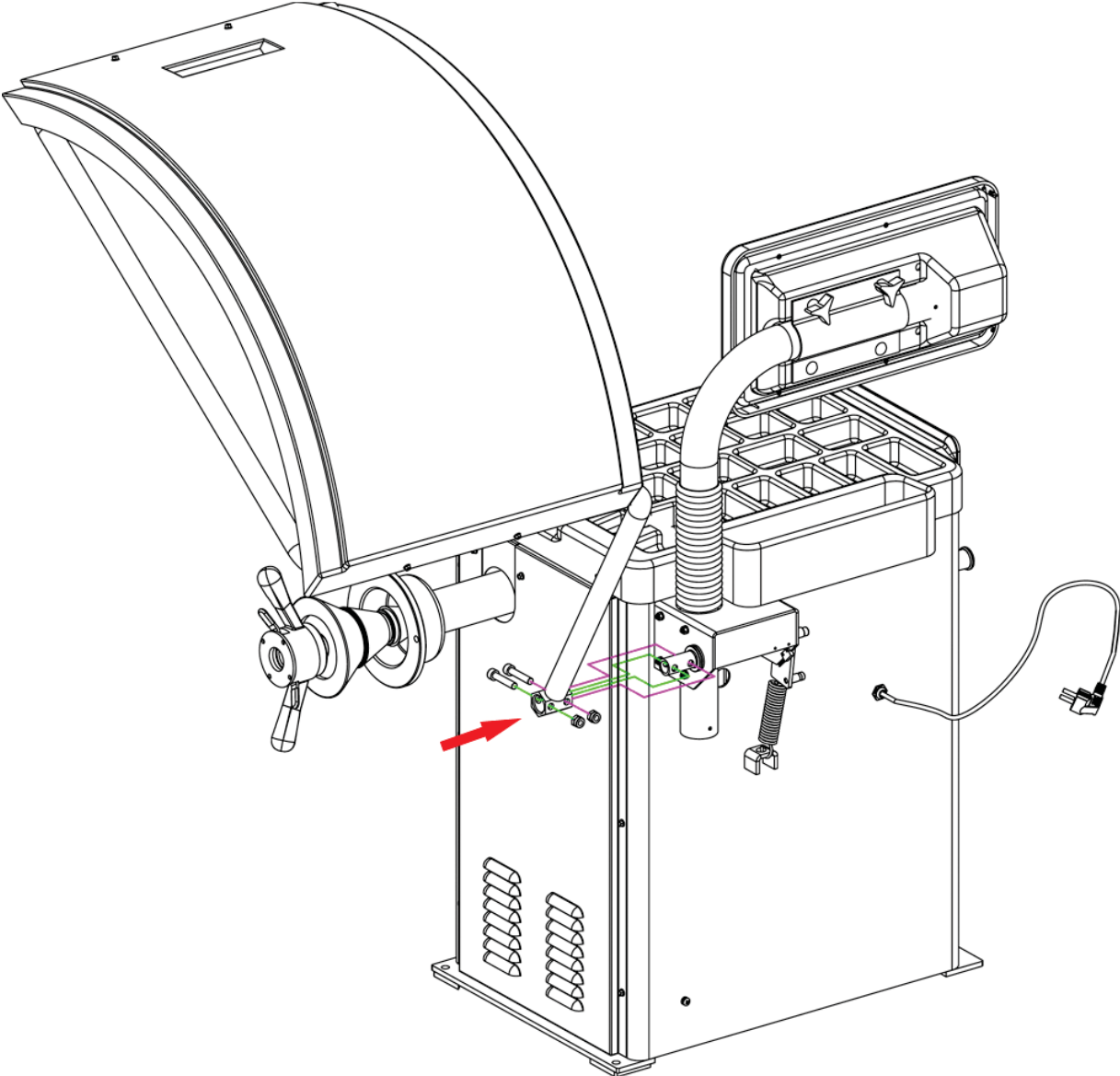

24. FIRE PROTECTION EQUIPMENT TO BE USED

	Dry Materials	Flammable Liquids	Electrical Equipment
Hydraulic	YES	NO	NO
Foam	YES	YES	NO
Powder	YES*	YES	YES
CO ₂	YES*	YES	YES

YES*: Can be used in the absence of more appropriate means or for small fires.



The information in the table above is general and can be used as a rough guide. For the responsibility for the use of each type of extinguisher, refer to the manufacturer.

25. ERROR INDICATION

DISPLAY	CAUSE	SOLUTION
ERR OPN	Protective cover not lowered	Lower the protective cover or change the setting and disable the hood function
ERR SP	Insufficient rotation speed, photocell coupler cannot collect signal	Check power board; Check the encoder board. Check the motor and belt. Check the computer board
ERR OFF	Stop error	Press the start key or raise the protective cover
ERR FAC	Factory set-up fault	Correct factory set-up
ERR USR	Customer set-up fault	Correct customer set-up
ERR REU	Reverse rotation is not correct	Troubleshoot encoder board or power board

LIMITED WARRANTY

Structural Warranty:

The following parts and structural components carry a five year warranty:

Columns	Arms	Uprights	Swivel Pins
Legs	Carriages	Overhead Beam	
Tracks	Cross Rails	Top Rail Beam	

Limited One Year Warranty

Tuxedo Distributors, LLC (Tuxedo) offers a limited one-year warranty to the original purchaser of Lifts and Wheel Service equipment in the United States and Canada. Tuxedo will replace, without charge, any part found defective in materials or workmanship under normal use, for a period of one year after purchase. The purchaser is responsible for all shipping charges. This warranty does not apply to equipment that has been improperly installed or altered or that has not been operated or maintained according to specifications.

Other Limitations:

This warranty does not cover:

1. Parts needed for normal maintenance
2. Wear parts, including but not limited to cables, slider blocks, chains, rubber pads and pulleys
3. Replacement of lift and tire changer cylinders after the first 30 days. A seal kit and installation instructions will be sent for repairs thereafter
4. On-site labor

Upon receipt, the customer must visually inspect the equipment for any potential freight damage before signing clear on the shipping receipt. Freight damage is not considered a warranty issue and therefore must be noted for any potential recovery with the shipping company.

The customer is required to notify Tuxedo of any missing parts within 72 hours. Timely notification must be received to be covered under warranty.

Tuxedo will replace any defective part under warranty at no charge as soon as such parts become available from the manufacturer. No guarantee is given as to the immediate availability of replacement parts.

Tuxedo reserves the right to make improvements and/or design changes to its lifts without any obligation to previously sold, assembled or fabricated equipment.

There is no other express warranty on the Tuxedo lifts and this warranty is exclusive of and in lieu of all other warranties expressed or implied, including all warranties of merchantability and fitness for a particular purpose.

To the fullest extent allowed by law, Tuxedo shall not be liable for loss of use, cost of cover, lost profits, inconvenience, lost time, commercial loss or other incidental or consequential damages.

This Limited Warranty is granted to the original purchaser only and is not transferable or assignable.

Some states do not allow exclusion or limitation of consequential damages or how long an implied warranty lasts, so the above limitations and exclusions may not apply. This warranty gives you specific legal rights and you may have other rights, which may vary from state to state.

Tuxedo Distributors, LLC.
1905 N. Main St. Suite C, Cleburne, TX 76033
Ph. 817-558-9337 / Fax 817-558-9740