



# ATDTCHD & ATDTCHDPA Tire Changer Installation and Operation Manual



## Features:

- Swing Arm Design
- Handles Tires up to 47" and Rim widths up to 15"
- Press Arm for Low Profile Tires
- Four Pneumatic Clamps and double-acting Cylinders
- Side mounted Bead Breaker
- Bead seating Inflation Jets in Clamping Jaws
- No Scratching - machine never contacts the Rim
- Lubricator, Water Separator and Air Pressure Regulator
- 26" x 26" square Turntable that accommodates Wheel Diameters up to 47"

## WARNING

This instruction manual is an important part of the product. Please read it thoroughly before installing, operating or performing maintenance on this machine.

This machine is only designed to mount, demount and inflate the tire in the specified scope and not for any other purpose.

The manufacturer will not be responsible for damage or injury caused by the improper operation of this equipment.

**NOTE:** This machine should only be operated by special trained qualified personnel. When operating, any unauthorized persons should be kept far away from the machine.

Please note the safety related decals attached to this machine. They should be replaced if illegible or missing.

Users and bystanders should use safety goggles or safety glasses with side shields that comply with current national standards. Also use non-skid safety shoes, hard hat, gloves and hearing protection when appropriate. To reduce the risk of personal injury, keep hair, loose clothing, fingers, and all body parts away from moving parts of the machine.

Tire changer should be installed and fixed on the flat and solid floor. Two feet of distance from the rear and lateral side of the machine to the wall can guarantee the perfect air flow and enough operation space.

Do not install the machine in explosive atmospheres, such as in the presence of flammable liquids, gases or dust.

Do not make any changes to this machine without the permission of the manufacturer. Any changes, modifications or installation of non-authorized parts can cause injury or death of the operator and damage to the machine.

Only operate the tire changer at the specified voltage and air pressure.

If you want to move the tire changer after installation, you should only do so under the guidance of professional service personnel.

## SAFETY LABEL INSTRUCTIONS

 <b>CAUTION</b>	 <b>WARNING</b>	 <b>WARNING</b>
		
KEEP HANDS CLEAR OF BEAD AREA WHEN INFLATING.	BE SURE TO READ ALL WARNING LABELS AND INSTRUCTION MANUAL PRIOR TO OPERATION OF THIS MACHINE	ALWAYS WEAR SAFETY GLASSES WHEN OPERATING THIS MACHINE <span style="float: right;">LA009</span>


**DANGER**



STAND CLEAR WHILE INFLATING TIRE. TIRE  
 OR WHEEL FAILURE UNDER PRESSURE  
 MAY CAUSE SERIOUS INJURY OR DEATH.


**WARNING**



DO NOT WEAR LOOSE CLOTHING,  
 LONG HAIR OR JEWELRY.  
 MOVING PARTS CAN SNAG AND PULL


**WARNING**



KEEP HANDS CLEAR OF ALL  
 PINCH POINTS LA008

### CAUTION LABELS



**Electrical Shock!**



**Do not place any part of your body under the demount tool.**



**When breaking tire bead, the bead breaking blade will quickly move to the**



**Note: When pressing the tire to the rim, the opened clamp cylinder may cause injury to the hand of the operator. Be sure not to touch the sidewall of the tire during pressing operation.**

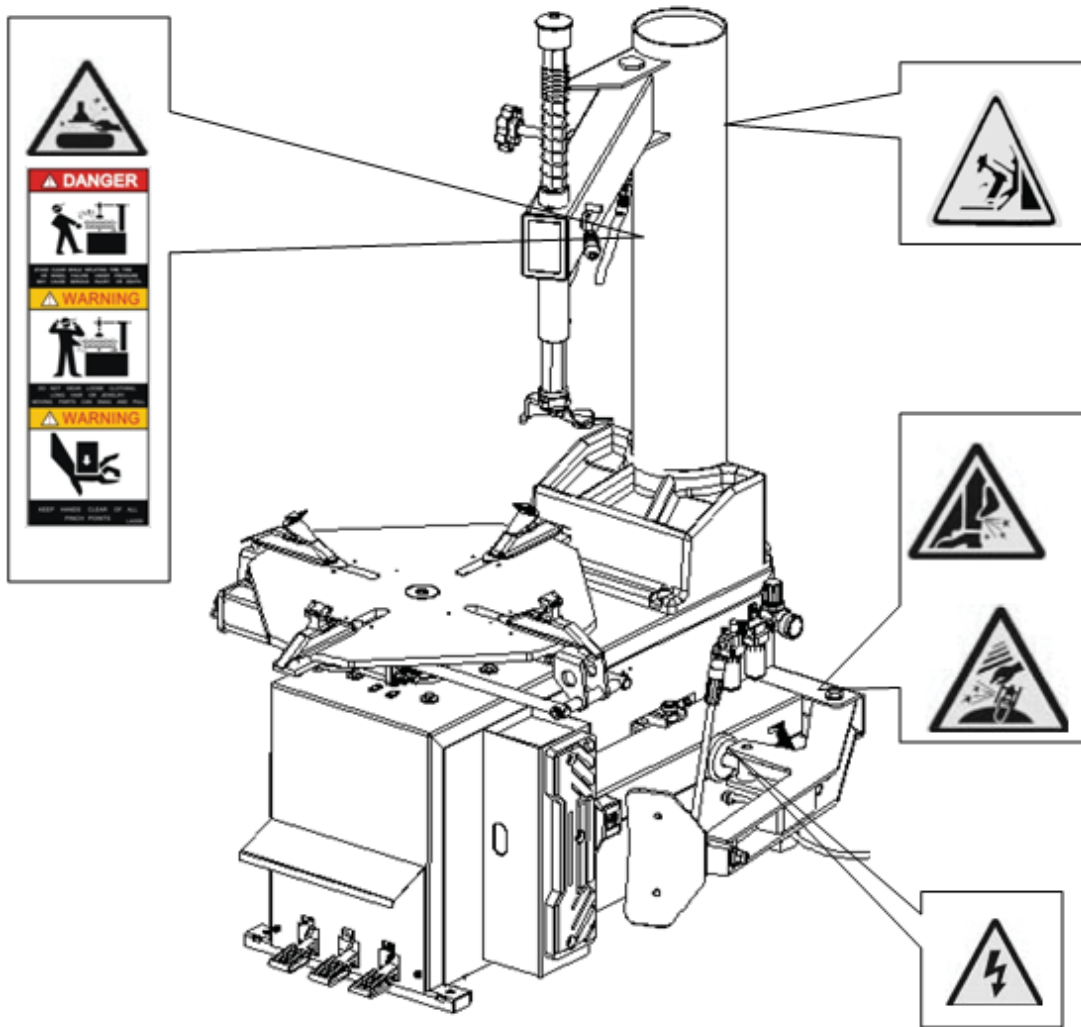


**When clamping the rim, do not place hand or other parts of the body in between the clamp & the rim.**

## SAFETY LABEL POSITION DIAGRAM

Please note the safety related labels attached to this machine. They should be replaced if illegible or missing.

Operators should always note the safety labels and understand the meaning of each label.



# **CONTENTS**

## **CHAPTER 1 - INTRODUCTION**

- 1.1 INTRODUCTION
- 1.2 TECHNICAL PARAMETERS
- 1.3 APPLICATION SCOPE
- 1.4 ENVIRONMENTAL REQUIREMENT

## **CHAPTER 2 - CONFIGURATION AND OPERATION**

## **CHAPTER 3 - INSTALLATION AND CALIBRATION**

- 3.1 OPEN PACKAGE CARTON
- 3.2 INSTALLATION OF THE COLUMN
- 3.3 AIR SOURCE INSTALLATION

## **CHAPTER 4 - DEMOUNT AND MOUNT TIRE**

- 4.1 DEMOUNT TIRE
- 4.2 MOUNT TIRE
- 4.3 INFLATION
- 4.4 RAPID INFLATION

## **CHAPTER 5 - MAINTANENCE AND REPAIR**

## **CHAPTER 6 - INSTALLATION & OPERATION OF THE ASSISTANT ARM(OPTIONAL)**

- 6.1 LEFT ASSISTANT INSTALLATION
- 6.2 RIGHT ASSISTANT INSTALLATION

## **CHAPTER 7 - TRANSPORTATION**

## **CHAPTER 8 - ELECTRICAL AND PNEUMATIC DRAWINGS**

## **CHAPTER 9 - GENERAL TROUBLESHOOTING**

## **ADDITIONAL INFORMATION: MACHINE OIL SAFETY DATA SHEET**

## **LIMITED WARRANTY**

# CHAPTER 1 - INTRODUCTION

## 1.1 INTRODUCTION

This series of equipment is the tire changer with fixed column and rocker arm tire changer. It is suitable to mount, demount and inflate all types of automotive and light truck tires including motorcycle tires (tube or tubeless). The operation is easy, convenient, safe and reliable.

## 1.2 TECHNICAL PARAMETER

- Operation Pressure: 8-10 bar (115 - 145 PSI)
- Motor: 110VAC-1PH, 60Hz
- Turntable Speed: 6 RPM
- Noise Level: <70dBa

## 1.3 APPLICATION SCOPE

Model #	Max. Wheel Diameter	Max. Wheel Width	Rim Diameter (Outer Clamping)	Rim Diameter (Inner Clamp)
ATDTCHD	1250mm (47")	400mm (15.74")	12" - 23"	10" - 20"

## 1.4 ENVIRONMENTAL REQUIREMENT

- Ambient temperature 0°C~45°C (32F - 113F)
- Relative humidity 30~95%  
Without dust and flammable / explosive gases
- The operation space around the machine will not smaller than the indicated in Fig.1

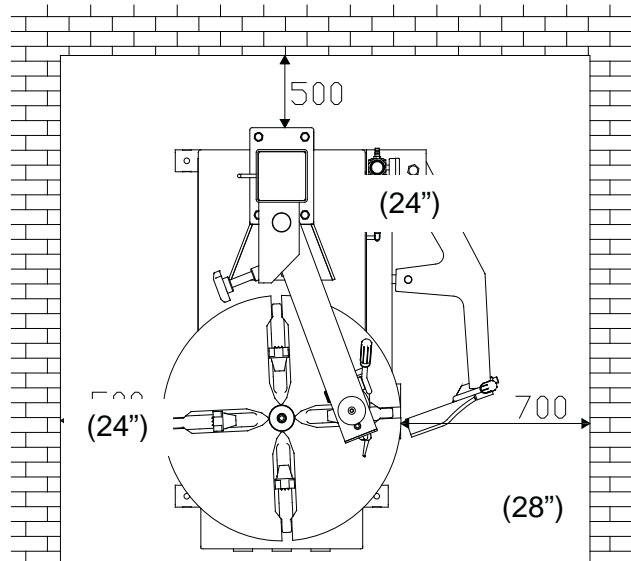


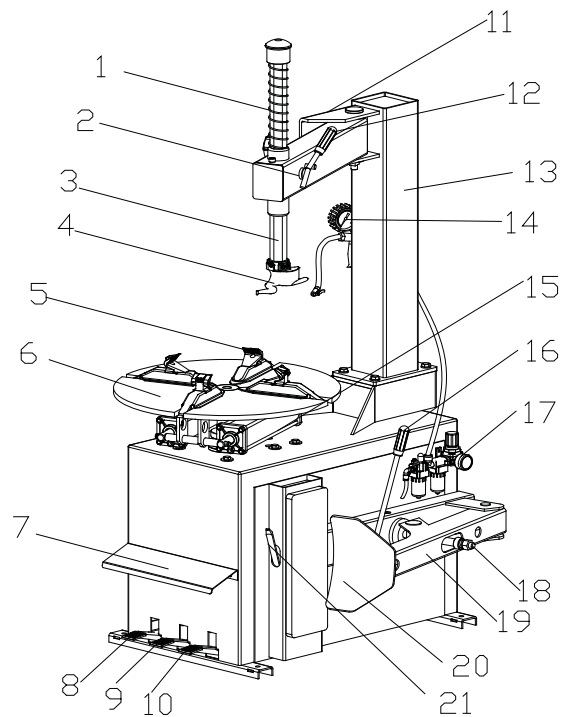
Fig. 1



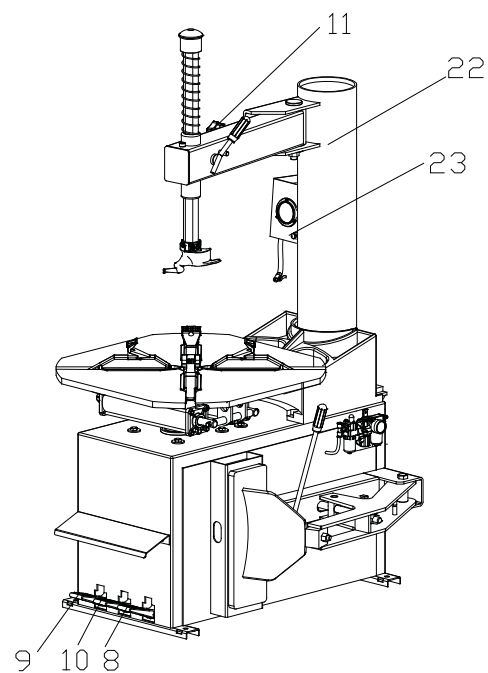
If the tire changer is installed outdoors, you must have a protective type shed or cover to protect it from rain and sun. It is prohibited to use near flammable gases!

## CHAPTER 2 - CONFIGURATION AND OPERATION

1. Vertical Shaft Spring
2. Lock Handle
3. Hexagon Shaft
4. Demount Head
5. Claw
6. Turntable
7. Operation Label
8. Turntable Pedal
9. Clamp Pedal
10. Bead Breaker Pedal
11. Limit Handle
12. Lock Handle
13. Column
14. Inflation Nozzle
15. Clamp Cylinder
16. Blade Handle
17. Air Filter, Regulator & Lubrication Unit
18. Bead Breaking Cylinder
19. Bead Breaker Arm
20. Bead Breaking Blade
21. Crowbar Tire Tool
22. Air Tank
23. Inflation Gauge Box



**Fig. 2**



**Fig. 3**

## CHAPTER 3 - INSTALLATION AND CALIBRATION

Before installation, carefully read the manual. Any unauthorized modifications and/or changes to any parts and/or components of the tire machine, may cause damage to the machine, and injury to the operator.

Have a certified electrician make all electrical connections on this equipment.

Never allow unauthorized personnel to operate this machine. Thoroughly train new persons/employees in the use, operation and care of this machine.

Before installation, carefully read the equipment list. If there are any questions or missing parts, please contact the dealer or representative.

To ensure the success of the installation, please have the following common tools:

Adjustable Wrenches, Socket Wrenches, Hex Keys, Pliers, Screw Driver & Hammer & multi-purpose Meter.

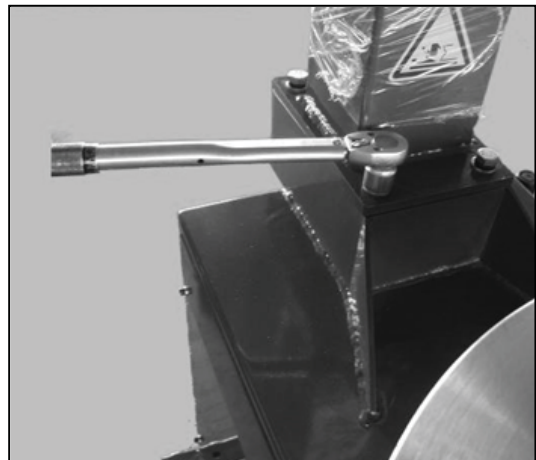
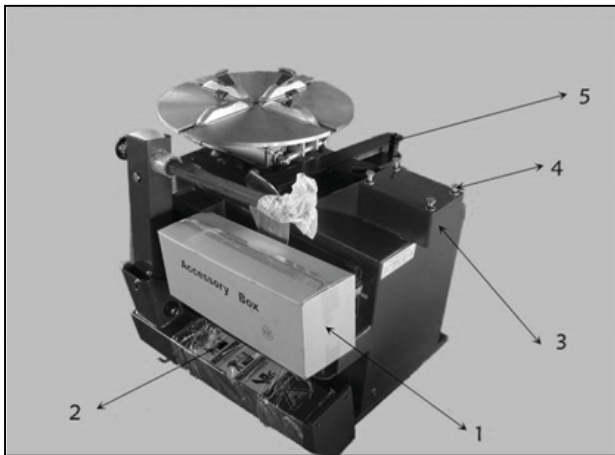
### 3.1 UNPACKING

3.1.1 According to the instructions on the package box, detach the box and remove the package material to check for machine damage and if all spare parts are included.

3.1.2 Keep the package material far away from the working site and dispose of properly.

### 3.2 INSTALLATION

3.2.1 After un-packaging the tire changer, take out Accessory Boxes (Fig. 4-1), Bead Breaking Arm (Fig. 4-5) and Column Assembly (Fig. 4-2). Ensure to position the machine according to the information noted in Chapter 1.4. ENVIRONMENT REQUIREMENT. Remove mounting bolts, lock washers & flat washers from Column Base (Fig. 4-4) in preparation to install Column to Base (Fig. 5).



3.2.2 Place the Column on Base with the direction of the warning label facing forward. Align the Column holes to the Base holes and mount with bolts, lock washers & flat washers, noted in the previous Chapter.



3.2.1 Using a Torque Wrench, tighten bolts to 52 ft.-lbs. (Fig. 5.) to secure Column to Base.

3.2.3 Use the wrench to remove the screw (Fig 6-3) Hexangular Shaft (Fig. 6-1) and take off the vertical Shaft Cap (Fig. 6-2).



When removing the screw on the vertical shaft cap, you'll need use the lock handle to lock the hexangular shaft to avoid sliding off to damage the machine or cause injury to personnel!

Install the vertical Shaft Spring (Fig. 7-1) on the vertical shaft. Mount the vertical shaft cap and mount the removed screw and assemble the hand wheel into the nut bushing of the rocker arm (Fig. 7-2).

3.2.4 Remove the Lock nut at the front end of the bead breaking/ cylinder piston rod (Fig. 8-1) and use the wrench to remove the nut on the bead breaking arm bolt (Fig. 8-4). Remove the bolt (Fig. 8-3) and hang the spring (Fig. 8-2).

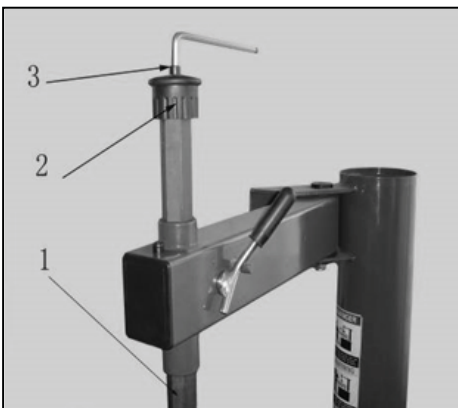


Fig. 6

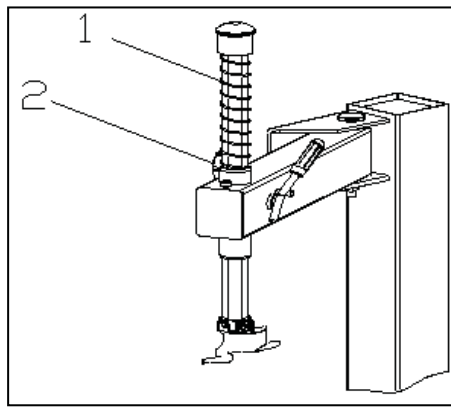


Fig. 7

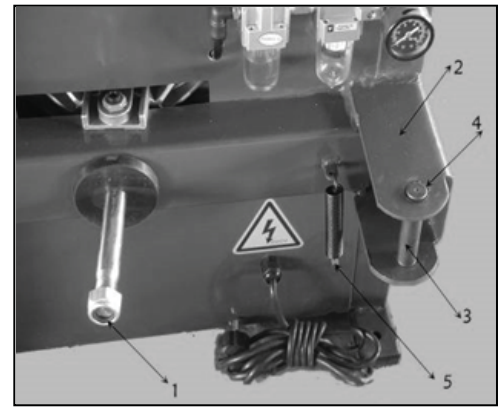


Fig. 8

3.2.5 Position the bead breaking Arm Shaft Bushing into the bead breaking Support Plate on the body (Fig. 9-1) to align the hole and install the bead breaking bolt (Fig. 9-2) and assemble the nut to lock (Fig. 8-4). Insert the piston rod (Fig.10-2) through the hole of the bead breaking slide bushing (Fig. 10-1). The surface of the slide bushing should be facing outwards (Fig. 10). Assemble the removed nut (Fig. 8-1) into the front end of the piston rod. The distance from the edge of the bead breaking blade to the bead breaker's rubber pad is 1-3/16" to 1-1/2" (30-40mm) as shown in Fig.11. Install the return spring (Fig. 9-3)

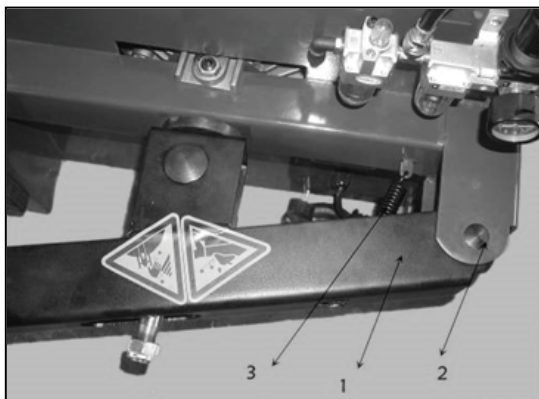


Fig. 9

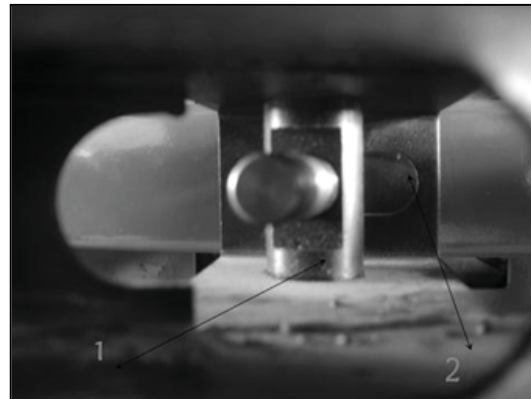


Fig. 10

**Note:** If the machine is the one with the quick inflation feature; please open the side panel and insert 2 pieces of Ø12 hose to the inlet of the quick inflation valve and to the Ø12 nozzle. Reinstall the side panel.

3.2.6 If being equipped with the tool box, you must fix firmly and the column completely installed.

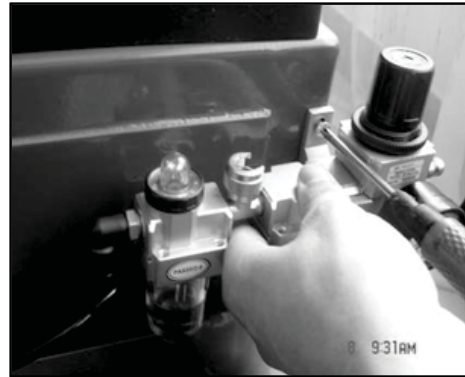
### 3.3 AFRL - AIR FILTER, REGULATOR & LUBRICATOR INSTALLATION:

Note: The AFRL has been detached and placed in the accessory box. The AFRL assembly will be installed at the customer's location during installation. This is done to prevent damage during shipment.

3.3.1 Remove the AFRL and mounting screw from the accessory box. Remove any oil or dust. Use the screw to mount the AFRL to the right side of the body (Fig. 12).



**Fig. 11**

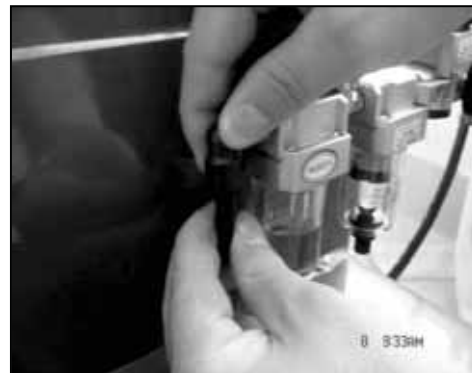


**Fig. 12**

3.3.2 To connect air hose: Detach the adapter on the  $\varnothing 8$  hose on the side wall of the body and insert it into the elbow fitting (Figs.13 &14). The adapter is to keep the hose from sliding into the body.



**Fig. 13**



**Fig. 14**

3.3.3 To connect the inflation gun or inflation gauge box: Inlay the adapter of the inflation gun or inflation gauge box into the groove (Fig. 15) on the open nut of the air regulator fitting. Tighten nut to connect the air regulator.



**Fig. 15**

3.3.4 The AFRL has been pre-adjusted at the factory. If it needs adjusting: **Pressure:** Lift up on the pressure adjustable knob (Fig. 16-1) and turn clockwise to increase air pressure. Meanwhile, if turned counter-clockwise, the air pressure will decrease. **Oil Feed:** Use a screw driver to turn the screw to adjust flow rate (Fig. 16-2). If turned clockwise, the oil flow speed will be reduced. If turned counter-clockwise, the oil flow will be increased.

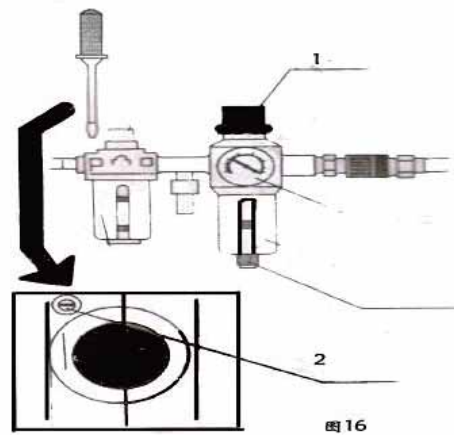


Fig. 16

## CHAPTER 4 - DEMOUNT AND MOUNT TIRE

### 4.1 DEMOUNT TIRE

4.1.1 Deflate the tire completely by pulling out the valve stem and/or core. Use a special tool (Wheel Balancer Hammer) to remove balance weights from the rim (Fig. 17).

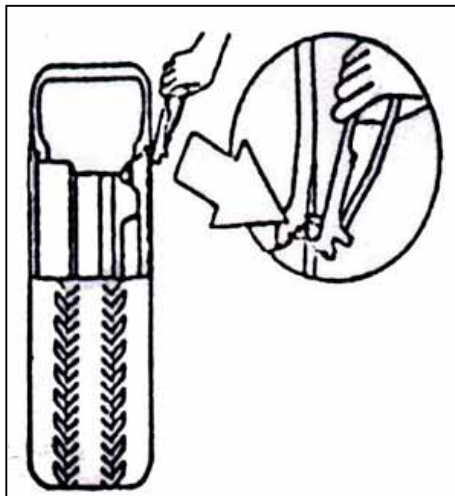


Fig. 17

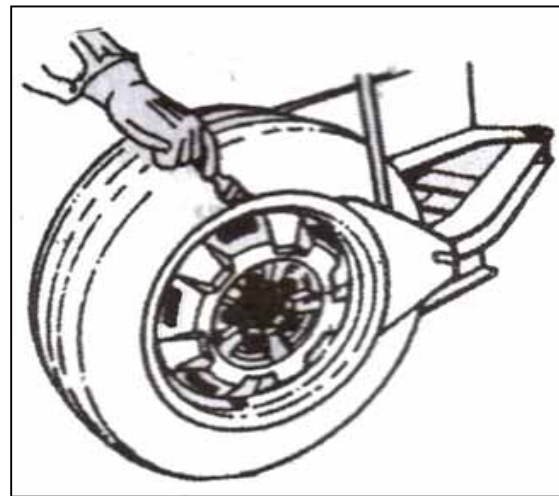


Fig. 18

4.1.2 Place the tire between the bead breaking blade and rubber contact pad (Fig. 18). Then step down on the Bead Breaker Pedal (Figs. 2-10 or 3-10) to detach the rim from the tire. Repeat the same operation on the other sections of the tire to fully detach from the rim. Place the wheel with the tire detached from the rim on the turntable and step on the Clamp Pedal (Figs. 2-9 or 3-9) to clamp the rim. Note: You can select either the outer clamping or inner clamping to properly clamp the wheel according to different rim types.



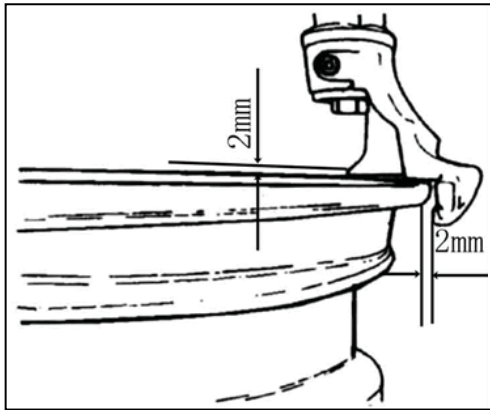
To detach the lip smoothly, you can use a brush to spread the lubricant or thick soap liquid between the lip and rim.

4.1.3 Position the Hexangular Shaft (Fig 2-3) to the working position to situate the demount tool to be close to the rim of the wheel, along with using the Limit Handle knob (Fig. 3-11) to position and secure Hex Shaft to rim. Once properly positioned, secure using the Lock Handle (Fig. 2-12).

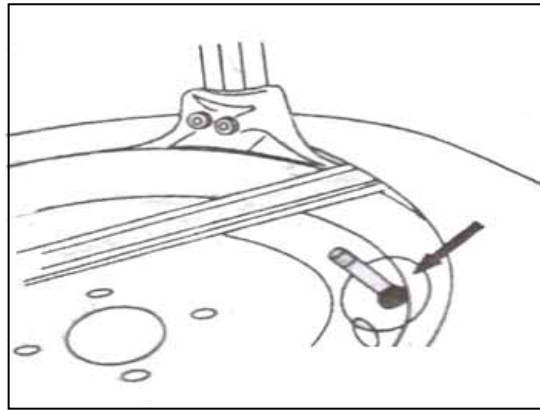
Note: The demount tool will automatically provide a small 2mm gap to the rim (Fig. 19).



The angle of the demount tool has been calibrated according to the standard rim of 13". If handling the extra-big or extra-small rim, you can reposition.



**Fig. 19**



**Fig. 20**

4.1.4 Use the included Crowbar Tire Tool to detach tire from rim as shown in Fig 20, using the Hex Shaft as a pivot point. Once the Crowbar is positioned, then step on the Turntable Pedal (Fig. 2-8) to rotate the turntable clockwise until the entire tire lip is completely detached from rim.

Note: If handling a tubed tire, try to avoid the damage to the tube, as the operator should keep the valve stem 4" (10cm) from the right side of the demount tool when demounting tires.



If the demounting of the tire gets jammed, please stop the machine immediately and then lift up the pedal to let the turntable rotate counterclockwise to remove the resistance!

4.1.5 When handling the tubed tire, Take out the tube and then move the lower lip upwards to the upper edge of the rim and then repeat the above steps to detach the other lip.



In the process of demounting the tire, you should keep your hands and the other parts of your body from the movable parts. Any necklaces, bracelets and/or loose clothing can cause injury to personnel!

#### **4.2 MOUNT TIRE:**



Before mounting a tire, ensure to check if the tire and rim are of the same dimension!

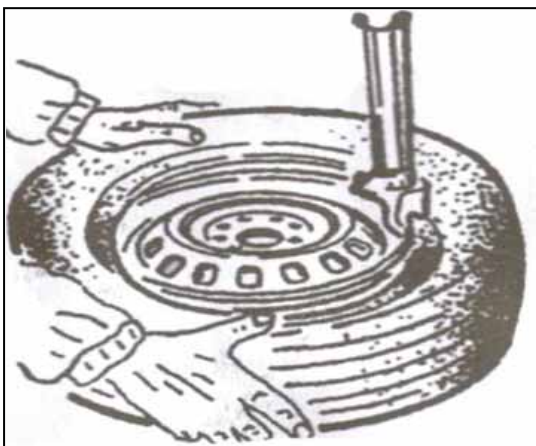
4.2.1 Clean the dirt and rust from the rim and position on the turntable. Secure rim to turntable using the clamps.

4.2.2 Spread the lubrication liquid or soap liquid around the lip of tire. Tilt the tire against the rim, keeping the front end upwards. Press down on the hexagonal shaft to move the demount tool arm to contact with the rim and lock. The left lip above the tail of the demount tool and the right lip will be positioned under the front end of the demount tool (Fig. 21). Then rotate the turntable clockwise to guide the bottom lip into the tire detaching slot.

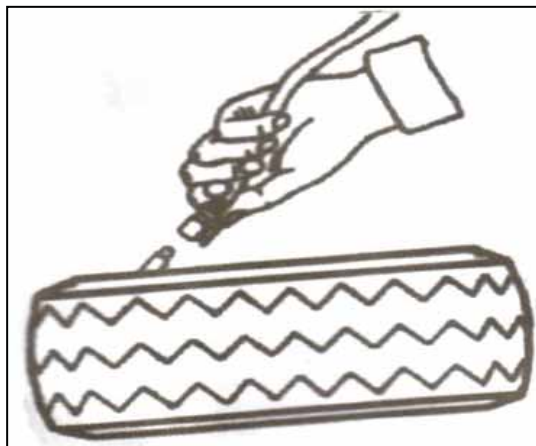


**Fig. 21**

4.2.3 If there is tube, place it in the tire and plug the core and assemble the lip according to the above mentioned step (Fig. 22).



**Fig. 22**



**Fig. 23**

### **4.3 INFLATION:**

When inflating the tire, please be careful and follow the operational process. Ensure to check the air routing to see if the air connection is ok. Note: the tire changer is equipped with an inflation pressure gauge to monitoring the inflation of the tire and the tire's pressure (Fig. 23).



1. Loosen the tire from the turntable.
2. Connect the inflation hose with the tire's preinstalled valve stem (Fig. 23)
3. In the process of inflation, you should stop the inflation periodically to confirm the pressure indicated on the pressure gauge so not to exceed the tire's pressure as specified by the manufacturer. The pressure decrease valve equipped in the machine will make the air pressure to not exceed 3.5bar or 51psi. The customer can obtain different inflation pressures by adjusting the regulator's pressure according to the requirement.
4. If the inflation pressures are too high, you can press down on the deflation button on the inflation device to reach the required air pressure.

#### 4.4 Rapid Inflation

If the tubeless tire does not fit securely to the rim, you can first apply 'rapid inflation' by using the bead seating Inflation Jets integrated into the clamps and then use common inflation method:



Fig. 24

1. Clamp the wheel and connect the inflation hose.
2. Step down on the Inflation Pedal to the lowest position (2) and quickly release the pedal when the tire is full to the upper position (1) as shown above in Fig 24.
3. Repeat stepping on the Inflation Pedal multiple times to confirm the pressure indicated on the pressure gauge does not exceed the pressure specified by the manufacturer.



During this process, you should always ensure the wheel has been tightly clamped!



#### **Explosive Warning!**

**When inflating, please follow the following instructions:**

- Carefully check that the tire and the rim are of the same dimension.
- Check the wear condition of the tire to confirm the tire isn't damaged before inflation!



When inflating the tire, please be careful. Keep your hands and body away from the tire.

## CHAPTER 5 - MAINTENANCE & REPAIR



Only a qualified technician can perform the maintenance on the tire changer. Before any maintenance is performed, shut off power. Meanwhile, shut off the air supply and push the air supply switch to the off position and completely deflate the residual air in the machine. To correctly use the tire changer and prolong its working life, it is necessary to periodically provide maintenance and repairs according to the instruction manual. If maintenance and/or repairs are not made, there is a possibility the operation and reliability of the machine may be affected, along with possible injury to the operator.

### Monthly Maintenance:

- Keep tire changer and working area clean.
- Clean hexangular shaft (Fig. 25). Use machine oil to lubricate shaft.
- Clean turntable, clamps and demount head. Use lithium based oil to lubricate (Fig 26).
- Check the oil level on the AFRL. If the oil level is low, add SAE-30 lubrication oil to fill line as required (Fig 27).
- Check the oil water separator trap and drain water, as required.
- Periodically check and adjust the tension of the drive belt. Properly adjust, by adjusting the nut in A and B to proper tension (Fig. 28).
- Check all connection parts and tighten as required.

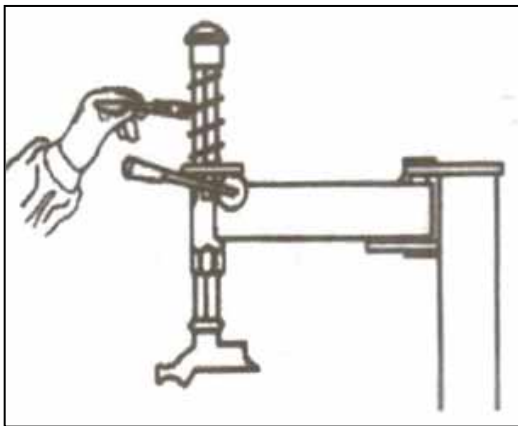


Fig. 25

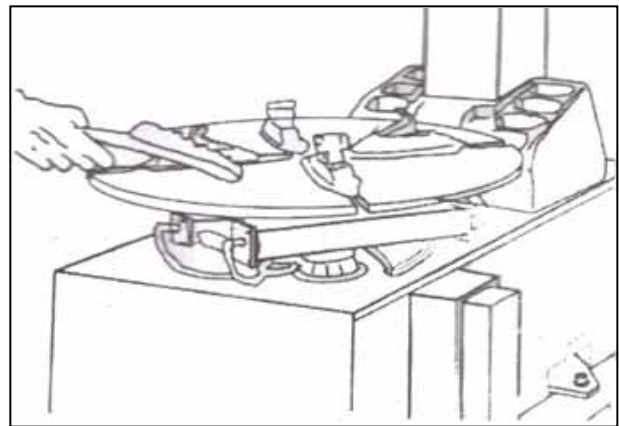


Fig. 26

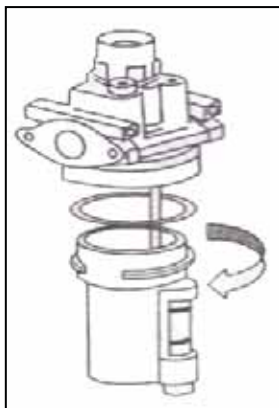


Fig. 27

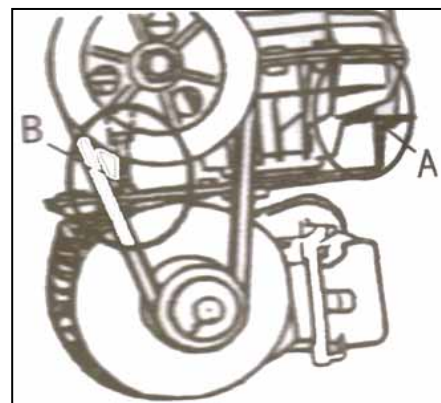


Fig. 28

## Hexangular Shaft & Lock Plate Gap Adjustment:

When pressing downward on the lock handle, the hexangular shaft will easily slide up & down vertically due to the weight of the hexangular shaft and the return spring. When the lock handle is rotated clockwise about 100 degrees, the cam connected to the handle will push up on the lock plate to lock the hexangular shaft into position. The gap distance can be increased or decreased by adjusting the adjustment nut (Fig. 29).

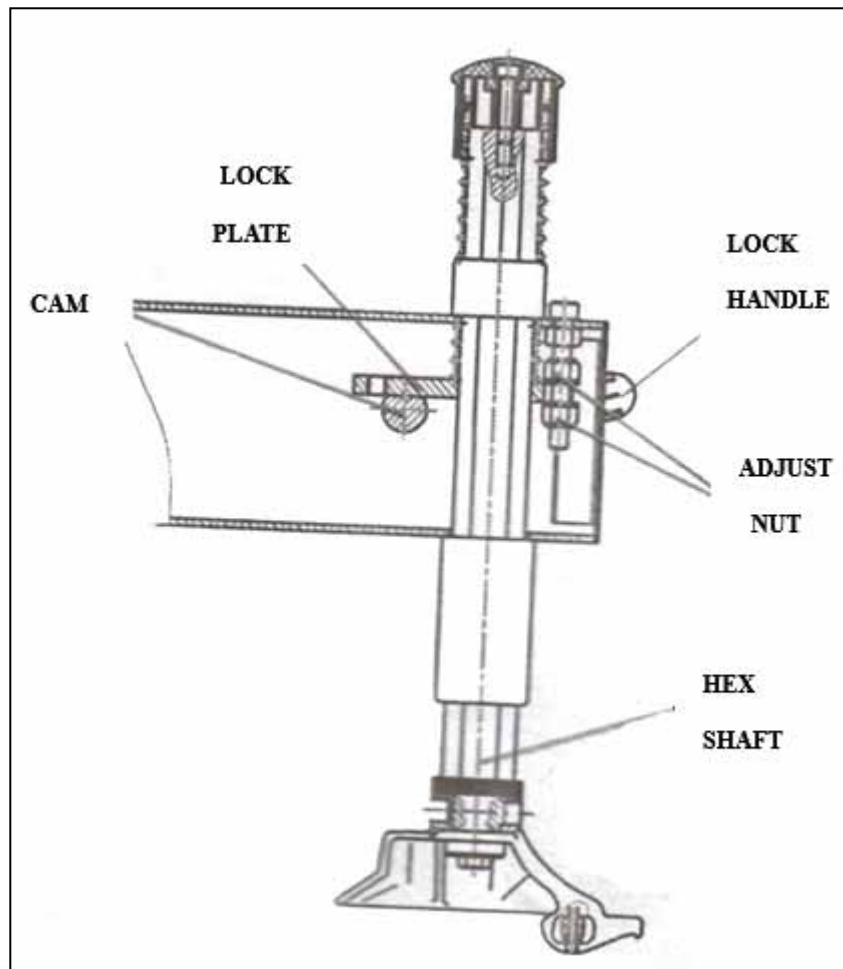


Fig. 29





**ATDTCHDPA**  
**Tire Changer with Left Side Press Arm Assist**  
**Installation and Operation Manual**  
**(Left Side Press Arm Assembly)**



## CHAPTER 6 - INSTALLATION & OPERATION - LEFT SIDE PRESS ARM

### 6.1 INSTALLATION - LEFT SIDE PRESS ARM

6.1.1 The Left Side Press Arm 'assistant' can be equipped on the tire changer which can handle a tire with the rim diameter of 20" to assist in the operation of demounting stiff and/or low profile tires. The Left Side Press Arm provides assistance for single operator capability.



Before installation, the power and air supply must be shut off!

6.1.1 The left and right side of the base plate of body of the tire changer can handle a tire with a diameter of more than 20" all have the installation hole for the left assistant prepared. Before installation, you can remove the side panel and take off the installation rubber plug. If there is a tool box, you should detach the tool box and set aside.

6.1.2 Unpack the Side Press Arm package and ensure all parts & components are included according to the packing list. After confirmation, take out the base assembly and install using the hex socket screw and washer (Fig. 30).

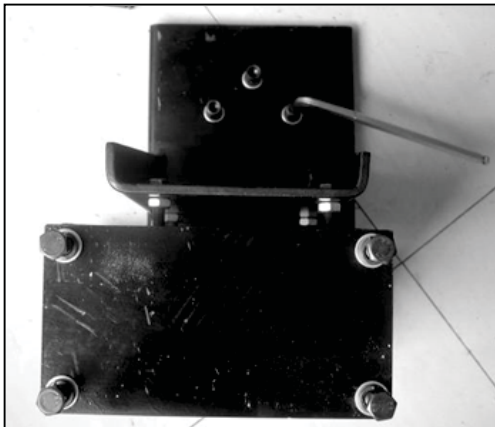


Fig. 30

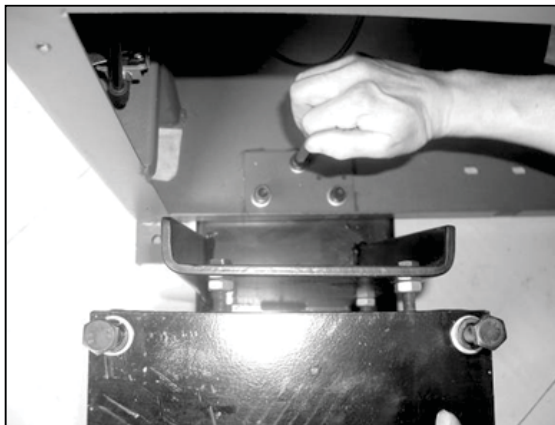


Fig. 31

6.1.3 Position the platform of the base plate, for the base assembly into the body through base plate on the left-back side of the body. Align the threaded holes to the reinforced holes on the body's base and connect using hex bolts and washers (Fig 31).

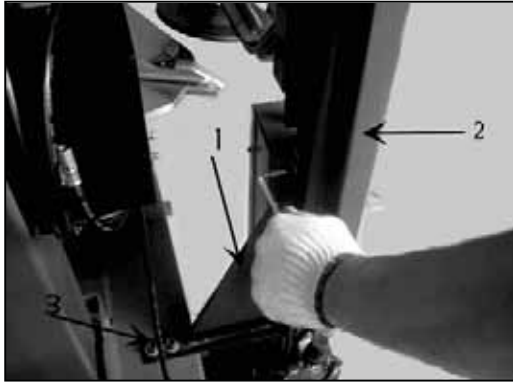
6.1.4 Install the body bracket (Fig.32-1) on the base assembly. Align holes and connect to base using the screws that were removed. Do not fully tighten at this time.



Fig. 32-1

6.1.5 Use the fixed supporting bracket (Fig. 33) to connect the body bracket and the body. Insert the screw to connect.

6.1.6 Connect the air source hose (Fig. 34-2) using the 'Y' Tee fitting to connect the outlet hose and the other end to connect with the inlet of the assistant pressure adjusting valve (Fig. 34-1).



**Fig. 33**



**Fig. 34**

6.1.7 According to the (Fig. 35), fit the bracket on the body that secures the tool box on the fixed bracket and then use the lock nut to tighten.



**Fig. 35**

6.1.8 Loosen the nut below the base and turn the screw clockwise until it's against the ground and is tight (Fig. 36). Re-install the side panel and tool box that was removed section 6.1.1.



**Fig. 36**

The installation of the Left Side Press Arm assembly is now complete.

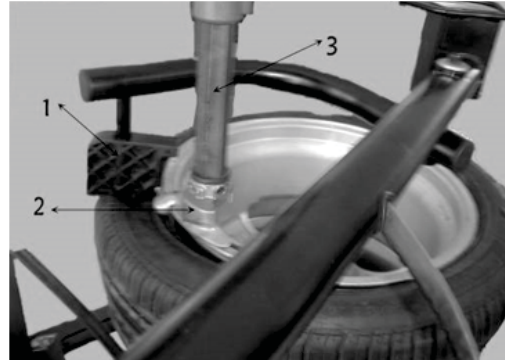
## 6.2 USING THE LEFT SIDE PRESS ARM

6.2.1 After detaching the tire from the rim according to the instruction of the Chapter 5, you can execute the following operations.

6.2.2 First, position the claws according to the dimension of the tire and then clamp the rim by the claws and position the tire press cone roller at the center of the rim (Fig. 37). Push down on the manual valve to press the rim down until the rim is lower than the surface of the claws. At this moment, you can immediately lock the rim. Lift up the support arm and place it at the working position and take off the press cone roller and place it on the support.

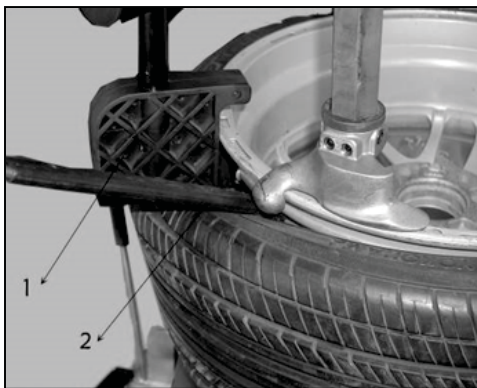


**Fig. 37**

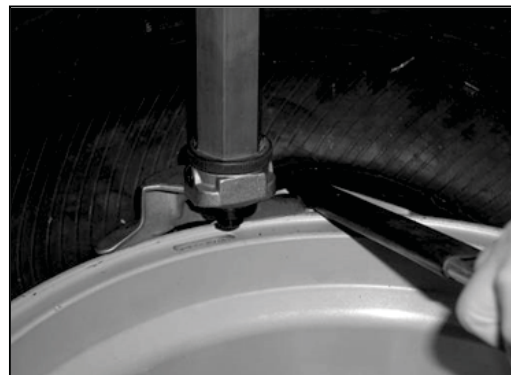


**Fig. 38**

6.2.3 Use the press (Fig. 38-1) to press down the tire by sections of the rim that is detached from the tire and use the brush to spread the lubricant on edge of the lip. Position the demount tool (FIG 40-2) in the demount position. Place the press beside the demount tool to press down the lip and insert the crowbar below the demount tool in between the rim and lip (Fig. 39). Then lift up the press and move it to the position opposite to the demount tool and press the lip into the tire detach groove and then rotate the crowbar to lift the lip onto the demount tool (Fig. 40). Rotate the turntable to detach the upper lip.



**Fig. 39**



**Fig. 40**

6.2.4 DETACH THE LOWER LIP: Use the disc to lift up the bottom section of the tire from the bottom of the mouth (Fig. 41) and detach the lower lip (Fig. 42).

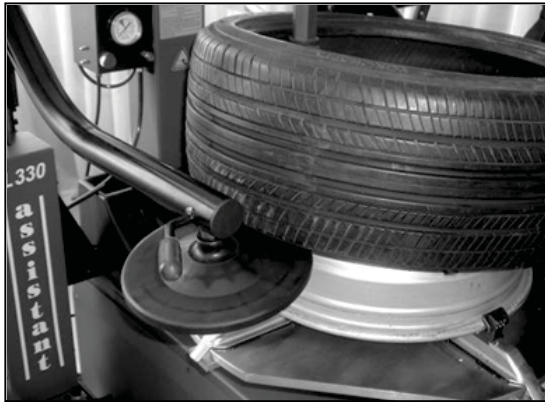


Fig. 41

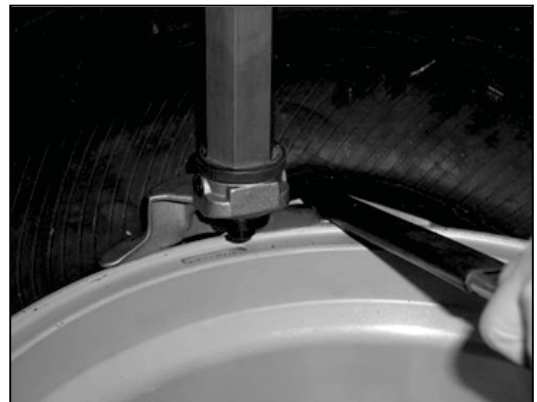


Fig. 42

6.2.5 MOUNT TIRE: First, according to the steps in section (4.2.1 thru 4.2.3), install the lower lip and use the press tool to press the lower lip as shown in Fig. 43. Rotate the turntable by about 90° then clamp and apply the demount tool (Fig. 44) while continually rotating the turntable until the operation is complete, as noted in section 6.2.5



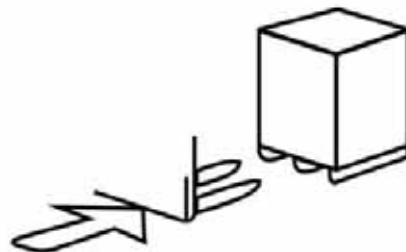
Fig. 43



Fig. 44

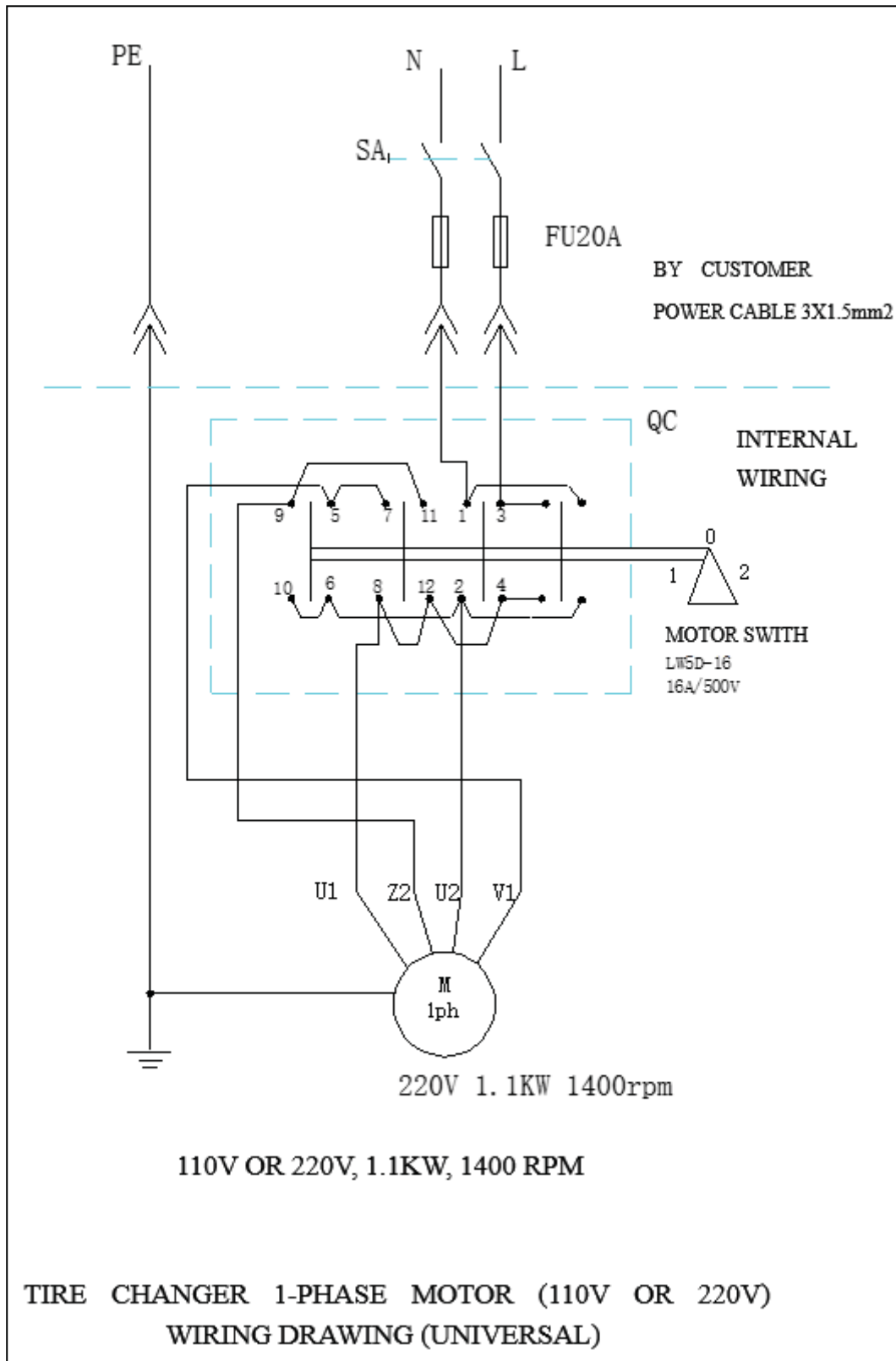
## CHAPTER 7 - TRANSPORTATION

It is highly recommended that the Tire Changer crate is transported by the forklift, once delivered. When transporting an unopened Tire Changer machine, ensure to place forks according to the markings on the outside of the crate packaging to reduce the possibility of damages.



**CHAPTER 8 - ELECTRICAL AND PNEUMATIC DRAWINGS**

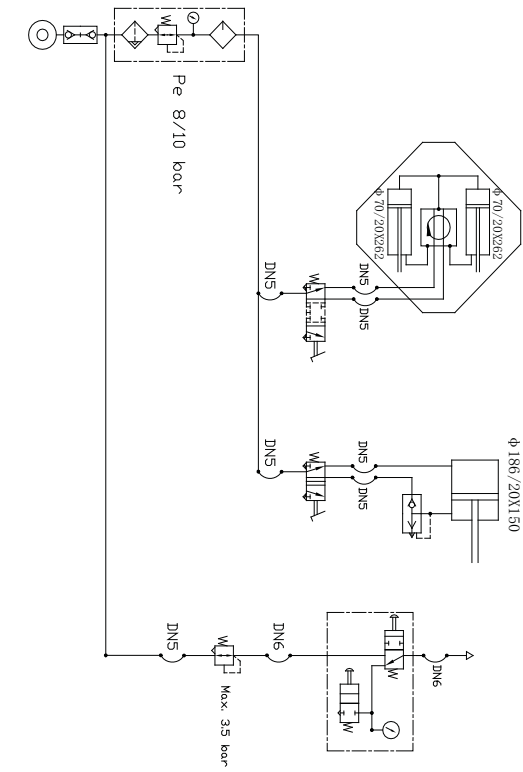
**110V OR 220V SINGLE PHASE ELECTRICAL DRAWING**



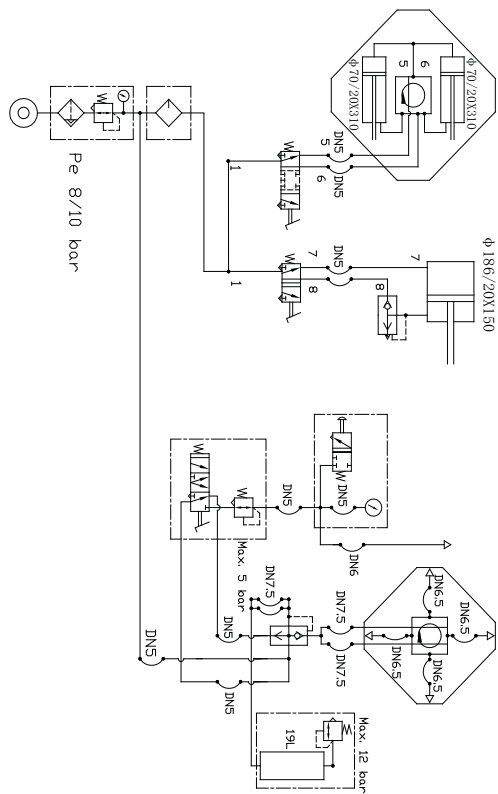
# PNEUMATIC DRAWING

SEMI  
PNEUMATIC

AUTOMATIC



SEMI AUTOMATIC PNEUMATIC  
(IT)





## CHAPTER 9 - GENERAL TROUBLESHOOTING

CHAPTER	REASON	TROUBLESHOOTING
Turntable rotates in one direction.	Universal switch defective.	Change Universal switch.
Turntable does not rotate.	Belt damage Belt too loose Motor or power source have problems  Universal switch contact damage	Change belt. Adjust the tension of the belt. Check motor, power source and power cord. Change motor if motor burned Change Universal switch
Turntable cannot clamp the rim normally.	Clamp claw worn Clamp cylinder air leakage	Change claws Change and/or seal parts that leak air.
Hexangular shaft will not lock	Lock plate not in position	Refer to Chapter 5
Operation pedals will not return to normal position.	Pedal return spring damage	Change torsion spring
Motor will not rotate or the output torque not sufficient.	Drive system jam Capacitor failure Voltage not sufficient Short-circuit internal defect	Remove the jam Change capacitor Wait for the restore of the voltage Remove & replace
Cylinder output force not enough.	Air leakage Air pressure too low	Change sealing parts Adjust the air pressure to meet the requirement
Air Leakage.	Air hose broken Pipe fitting broken Defective pneumatic component Lack of sealant	Change broken parts.  Apply sealant as required.



## ADDITIONAL INFORMATION: MACHINE OIL SAFETY DATA SHEET

### MACHINE OIL SAFETY DATA SHEET

#### MOBIL XHP 222

ITEM	QUALITY STANDARD
Penetration rate 25°C mm/10	280
Dropping point °C	280
Anti-corrosion	passed
Basic oil viscosity	220
Oxidize stability 100h pressure-drop Kpa	35
Water lose percentage 79%	5
Copper Corrosion	1A

#### SAE30# LUBRICATION OIL

ITEM	QUALITY STANDARD
density 15°C	0.893
Flash point	224
Pour point °C	-18
viscosity 40°C	100
viscosity 100°C	11.2
Viscosity index	97

#### 2# LITHIUM BASE GREASE

ITEM	QUALITY STANDARD
Penetration rate mm/10	278
dropping point °C	187
copper corrosion 100°C 24 h	No change
oxidize stability (99°C 100 h)	0.2
anticorrosion (52°C 48 h)	1 level
similarity viscosity (-15°C、 $10S^{-1}$ ) / (Pa·S)	800
water lose(35°C 1h) %	8

#### CKC460 INDUSTRIAL GEAR OIL

ITEM	QUALITY STANDARD
Viscosity 40°C	461
Viscosity index	92
Flash point °C	212
Freezing point °C	-26
copper corrosion 100°C 3 h	1A
mechanical impurity	0.007
Pour point	-10

# LIMITED WARRANTY

## Structural Warranty:

The following parts and structural components carry a five year warranty:

Columns	Arms	Uprights	Swivel Pins
Legs	Carriages	Overhead Beam	
Tracks	Cross Rails	Top Rail Beam	

## Limited One Year Warranty

Tuxedo Distributors, LLC (Tuxedo) offers a limited one-year warranty to the original purchaser of Lifts and Wheel Service equipment in the United States and Canada. Tuxedo will replace, without charge, any part found defective in materials or workmanship under normal use, for a period of one year after purchase. The purchaser is responsible for all shipping charges. This warranty does not apply to equipment that has been improperly installed or altered or that has not been operated or maintained according to specifications.

## Other Limitations:

This warranty does not cover:

1. Parts needed for normal maintenance
2. Wear parts, including but not limited to cables, slider blocks, chains, rubber pads and pulleys
3. Replacement of lift and tire changer cylinders after the first 30 days. A seal kit and installation instructions will be sent for repairs thereafter
4. On-site labor

Upon receipt, the customer must visually inspect the equipment for any potential freight damage before signing clear on the shipping receipt. Freight damage is not considered a warranty issue and therefore must be noted for any potential recovery with the shipping company.

The customer is required to notify Tuxedo of any missing parts within 72 hours. Timely notification must be received to be covered under warranty.

Tuxedo will replace any defective part under warranty at no charge as soon as such parts become available from the manufacturer. No guarantee is given as to the immediate availability of replacement parts.

Tuxedo reserves the right to make improvements and/or design changes to its lifts without any obligation to previously sold, assembled or fabricated equipment.

There is no other express warranty on the Tuxedo lifts and this warranty is exclusive of and in lieu of all other warranties expressed or implied, including all warranties of merchantability and fitness for a particular purpose.

To the fullest extent allowed by law, Tuxedo shall not be liable for loss of use, cost of cover, lost profits, inconvenience, lost time, commercial loss or other incidental or consequential damages.

This Limited Warranty is granted to the original purchaser only and is not transferable or assignable.

Some states do not allow exclusion or limitation of consequential damages or how long an implied warranty lasts, so the above limitations and exclusions may not apply. This warranty gives you specific legal rights and you may have other rights, which may vary from state to state.

Tuxedo Distributors, LLC.  
1905 N. Main St. Suite C, Cleburne, TX 76033  
Ph. 817-558-9337 / Fax 817-558-9740