



ATD-8625
Front Wheel Drive Bearing Adapter Kit
Owner's Manual



Features:

- For front wheel drive cars and light trucks
- Black oxide finish
- Packed in a custom case for easy transport and storage
- Shipping Weight: 24.60 lbs.

Includes:

- (13) Bushings
- (4) Sleeves
- (2) Sleeve Plates
- (1) Spacer
- Sliding Screw, Nut and Washers

SPECIFICATIONS:

Construction	Carbon Steel
Finish	Black Oxide
Bushing Hardness	HRC25 to HRC35
Bushing Range(Outside Diameter)	2.18",2.5",2.62",2.78",2.82",2.82,2.88",2.9",2.96", 3.05",3.21",3.28",3.48"
Sleeve Sizes	3" O.D. × 2.5" Long 3.25" O.D. × 2.53" Long 3.63" O.D. × 2.53" Long 4" O.D. × 2.53" Long
Sleeve Plate Sizes	3.25" O.D. × 2.72" Step 4" O.D. × 3.2" Step
Sliding Screw Size/Type	7.5" Long × 0.75" Diameter/10 NAT
Nut Size	3" Long × 0.75" Diameter
Washer Size	1.5" O.D

CONTENTS

Section 1—Domestic Vehicles

Chrysler/Plymouth/Dodge	3
Ford/Mercury	5
Saturn	8

Section 2—Import Vehicles

Acura	10
Audi	12
Eagle.....	14
Geo	16
Honda	18
Hyundai	20
Infiniti.....	22
Lexus	24
Mazda	26
Mitsubishi.....	28
Nissan.....	30
Subaru.....	32
Toyota.....	34
Volkswagen.....	36

Section 3—Parts List

Parts List.....	38
------------------------	-----------

* For ALL applications, lubricate the sliding screw before use.

* Spacer 8625-24 can be used in applications where using less threads on the sliding screw is desired. It can be used in place of 8625-22 in many cases, reducing the reach of the screw.

Chrysler/Plymouth/Dodge

R= Remove I= Install	8625 -02	8625 -01	8625 -06	8625 -11	8625 -12	8625 -13	8625 -14	8625 -15	8625 -16	8625 -17	8625 -18	8625 -19	8625 -03	8625 -04	8625 -05	8625 -07	8625 -08	8625 -09	8625 -10
Chrysler 1982-88 All 1989-90 LeBaron 1989-90 Town & Country													R	I	RI	I		RI	I
Plymouth 1980-83 All 1983 Voyager 1984-90 Acclaim, Caravelle, Reliant, Sundance 1984-90 Horizon Turismo 1984-90 Voyager													R	I	RI	I		RI	I
Dodge 1980-83 All 1982-84 Rampage 1984-87 Charger 1984-89 Dynasty, Shelby Charger, 600 1984-89 Omni GLH 1984-90 Aries, Lancer, Shadow 1984-90 Caravan 1984-90 Daytona 1984-90 Omni 1989-90 Spirit													R	I	RI	I		RI	I
1993-94 Colt 1995-00 Neon 2001-04 Neon 2001-04 PT Cruiser	R		RI													I		RI	I

1. Determine if the vehicle has a trapped rotor or a floating rotor.
2. Assemble the tool components as shown in Figure 1, and press out the worn bearing.

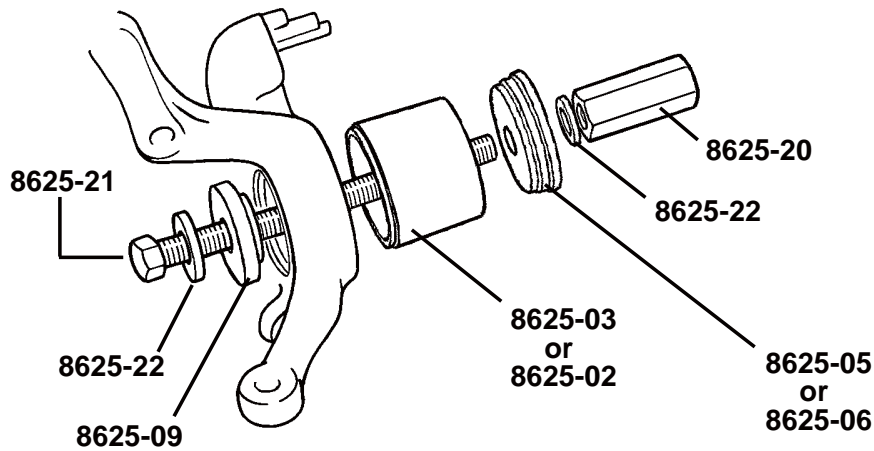

Figure 1

3. Lightly lubricate the new bearing, and position it for installation with the tool components assembled as shown in Figure 2. Press the bearing into the spindle assembly until it bottoms out.
4. Fasten the bearing retainer in place using the bearing retainer bolts. (On Neon vehicles, install the snap ring in the knuckle.)
5. Assemble tool components as shown in Figure 3. Lightly oil the hub assembly, and install the hub.

Important: The bearing installer must be assembled with the flat side toward the bearing and the small diameter pilot on the side away from the bearing.

6. Assemble the remaining vehicle components that were removed for bearing replacement:
 - . Lower ball joint to steering knuckle assembly
 - . Brake rotor
 - . Disc brake caliper
 - . Outer tie rod nut and tie rod
 - . Axle nut
 - . Front tires

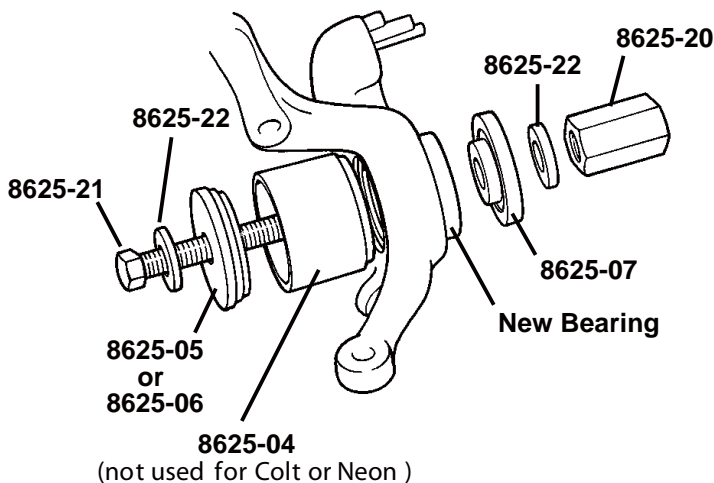

Figure 2

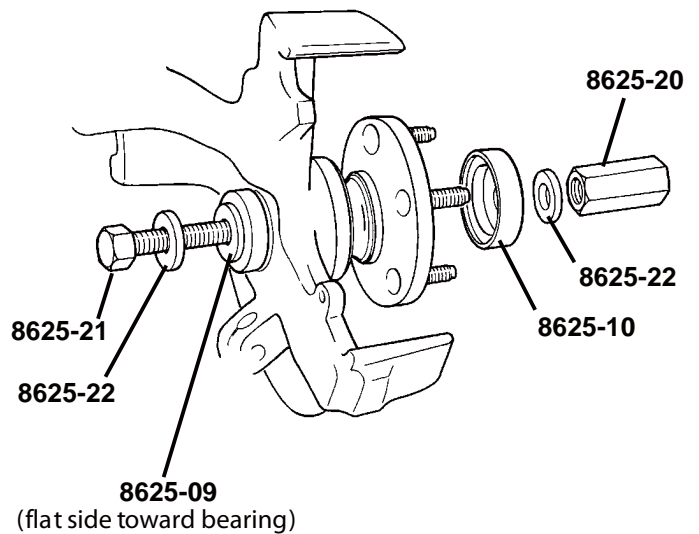

Figure 3

Ford/Mercury

R= Remove I= Install	8625 -02	8625 -01	8625 -06	8625 -11	8625 -12	8625 -13	8625 -14	8625 -15	8625 -16	8625 -17	8625 -18	8625 -19	8625 -03	8625 -04	8625 -05	8625 -07	8625 -08	8625 -09	8625 -10
1983-90 Escort/Lynx. EXP /Ln7 1983-94 Tempo/Topaz														R	RI		I	R	I
19886-95 Taurus/Sable 1995-98 Windstar													R		RI	I		R	I
1991-99 Escort/Tracer						RI							R		RI				I
1993-97 Probe	R		RI							I								R	I
1993-99 Villager	R		R							I					I			RI	I
1995-01 Contour/Mystique								I					R		RI			R	I
2000-04 Focus	R		RI			I												RI	I
1994-97 Aspire																		I	I

1. Determine if the vehicle has a trapped rotor or a floating rotor.
2. Assemble the tool components as shown.

Important: The internal chamfer on the end of the tube (No. 8625-03 or 8625-04) faces the wheel knuckle. The chamfer aligns the tube with the wheel knuckle so it doesn't slip off the surface and cock.

The 1986-95 Taurus/Sable application uses the larger tube (No.8625-03) with the 2-step adapter (No.8625-05). See Figure 1.

The 1983-94 Tempo/Topaz and 1983-90 Escort/Lynx application uses the smaller tube (No.8625-04) with the 2-step adapter. See Figure 1.

The 1995-2001 Contour/Mystique application uses bearing installer No.8625-09.see Figure 2.

The 1991-99 Escort/Tracer application uses bearing installer No.8625-13.see Figure 2.

The 1993-99 Villager application uses bearing installer No.8625-02 and step adapter No.8625-06. See Figure 2.

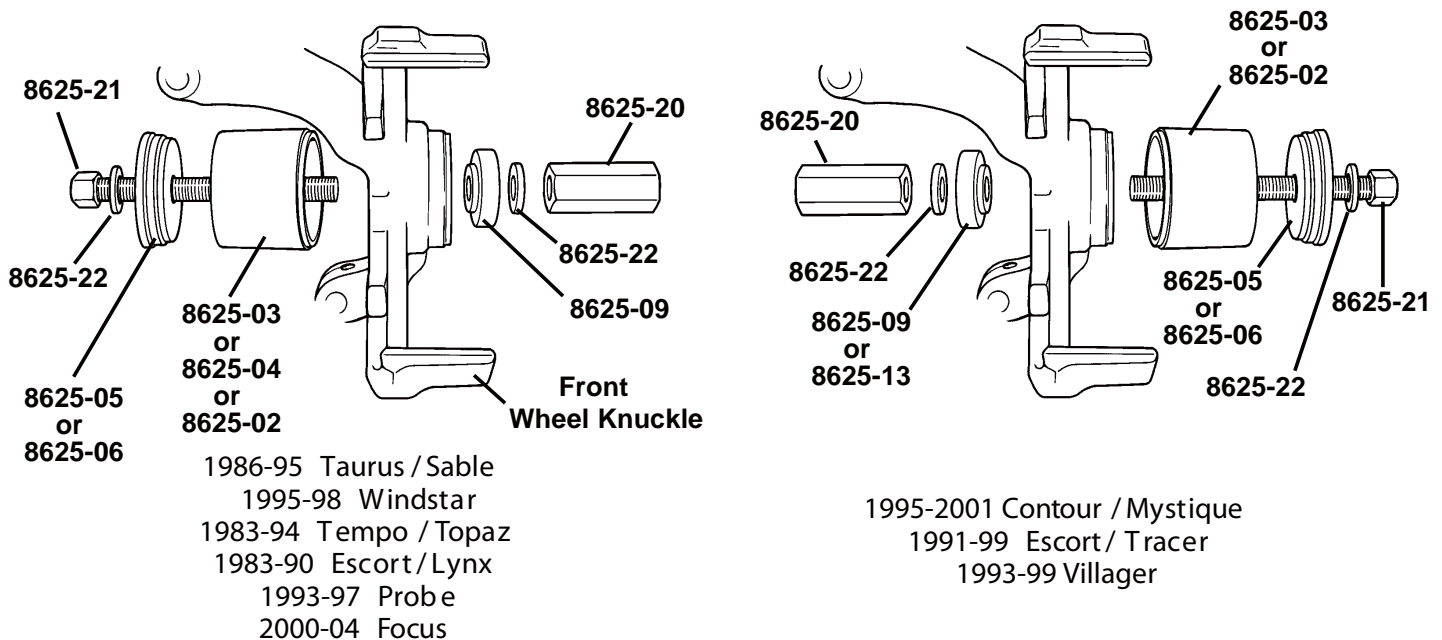

3. Use a wrench to hold the forcing screw (Figure 3) or forcing screw nut (Figure 4), and press out the worn bearing.

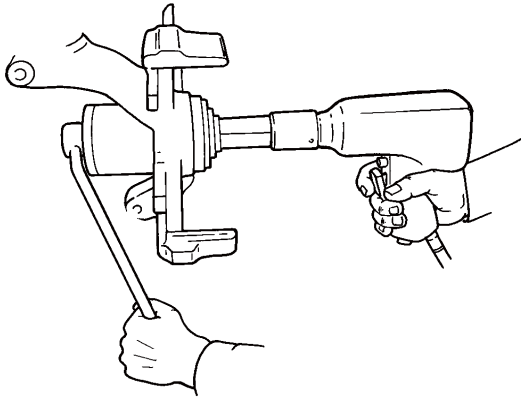

1986-95 Taurus / Sable
 1995-98 Windstar
 1983-94 Tempo / Topaz
 1983-90 Escort / Lynx
 1993-97 Probe
 2000-04 Focus

Figure 3

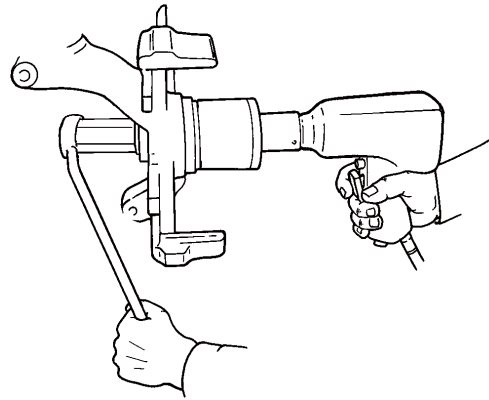

1995-2001 Contour / Mystique
 1991-99 Escort / Tracer
 1993-99 Villager

Figure 4

4. Lightly lubricate the new bearing, and position it for installation with the tool components assembled as shown.

The 1986-95 Taurus/Sable application uses the larger bearing installer (No.8625-07). See Figure 5.

The 1983-94 Tempo/Topaz and 1983-90 Escort/Lynx application uses the smaller bearing installer (No.8625-08). See Figure 5.

The 1995-2001 contour/Mystique application uses bearing installer No.8625-15 .see Fig.6.

Important: To prevent damage to the seal lip, remove the seal before installing the bearing.

The 1993-99 Villager application uses adapter No. 8625-17. See Fig.6.

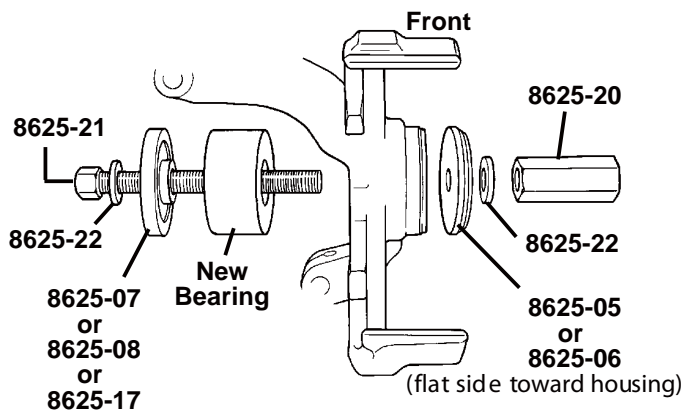

1986-95 Taurus / Sable
 1995-98 Windstar
 1983-94 Tempo / Topaz
 1983-90 Escort / Lynx
 1993-97 Probe
 2000-04 Focus

Figure 5

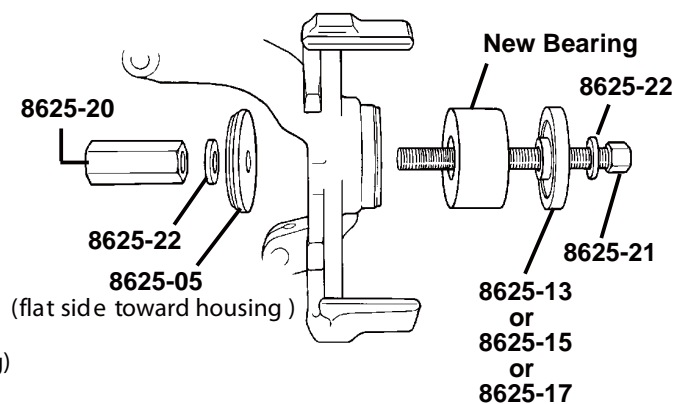

1995-2001 Contour / Mystique
 1991-99 Escort / Tracer
 1993-99 Villager

Figure 6

5. Press the bearing into the spindle assembly until it bottoms, Install the snap ring that was removed from the knuckle.

6. Assemble the tool components as shown in Figure 7 and install the hub.

Important: The bearing installer must be assembled with the flat side toward the bearing and the small diameter pilot on the side away from the bearing.

On the 1991-99 Escort/Tracer application, install the seal after the wheel hub has been assembled.

7. Assemble the remaining vehicle components that were removed for bearing replacement:

- . Lower ball joint to steering knuckle assembly
- . Brake rotor
- . Disc brake caliper
- . Outer tie rod nut and tie rod
- . Axle nut
- . Front tires

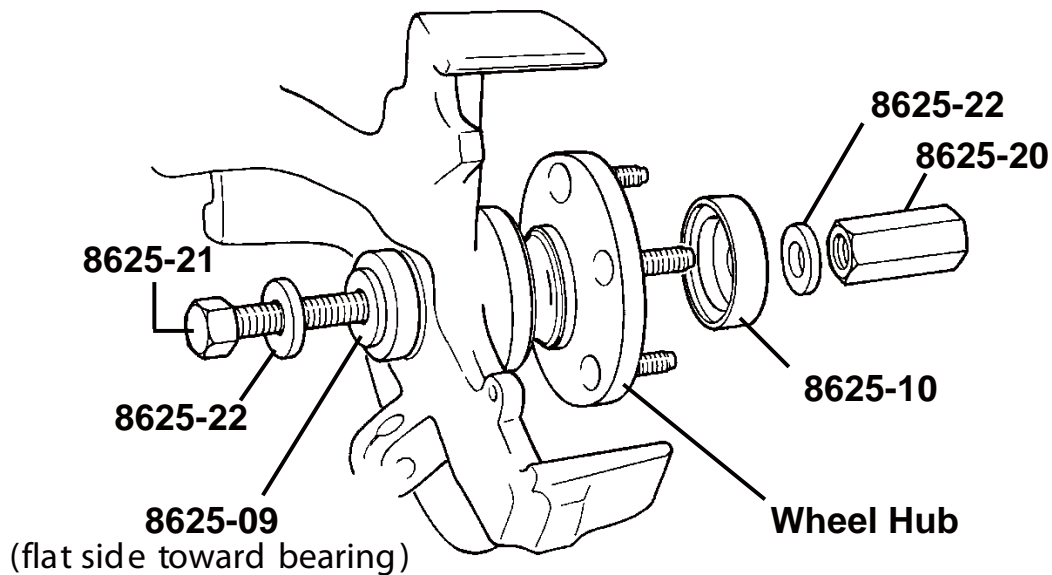

Figure 7

Saturn

R= Remove I= Install	8625 -02	8625 -01	8625 -06	8625 -11	8625 -12	8625 -13	8625 -14	8625 -15	8625 -16	8625 -17	8625 -18	8625 -19	8625 -03	8625 -04	8625 -05	8625 -07	8625 -08	8625 -09	8625 -10
1991-99 SC,SC1,SC2,SL, SL1,SL2,SW1,SW2													R		RI		I	RI	I

1. Determine if the vehicle has a trapped rotor or a floating rotor.
2. Assemble the tool components as shown in Figure 1. Hold the forcing screw with a wrench, and press the worn bearing out as shown in Figure 2.

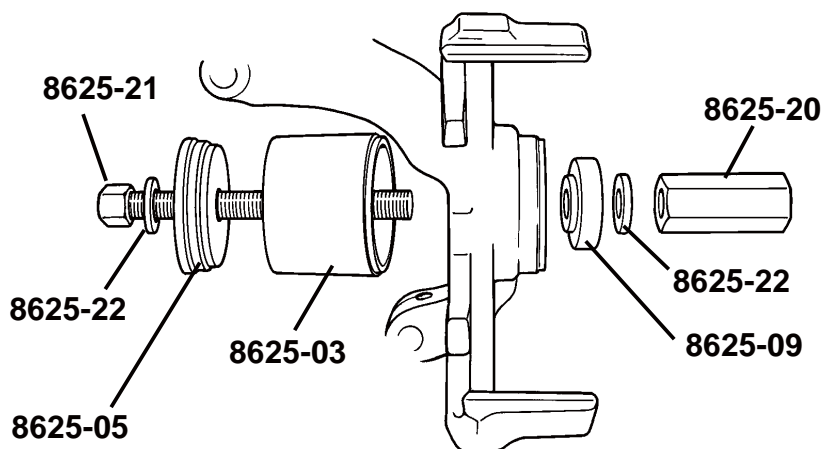

Figure 1

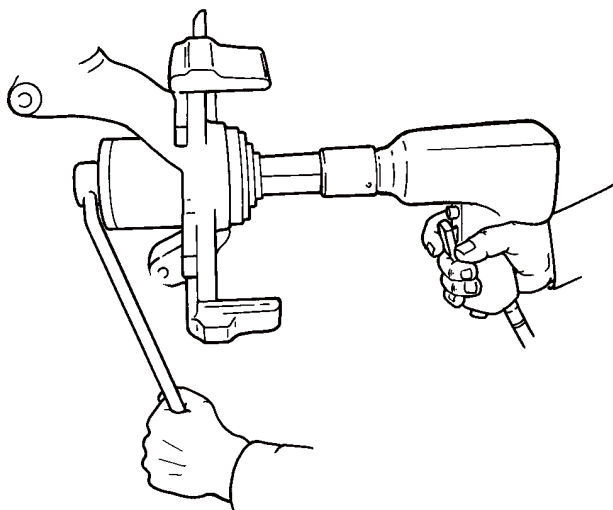

Figure 2

3. Lightly lubricate the new bearing, and position it for installation with the tool components assembled as shown in Figure 3.

Important: Assemble the adapter with the flat side toward the housing, and the small diameter pilot on the side away from the housing.

4. Press the bearing into the spindle assembly until it bottoms, install the snap ring.

5. Assemble the tool components as shown in Figure 4, and install the hub.

Important: The bearing installer must be assembled with the flat side toward the bearing and the small diameter pilot on the side away from the bearing.

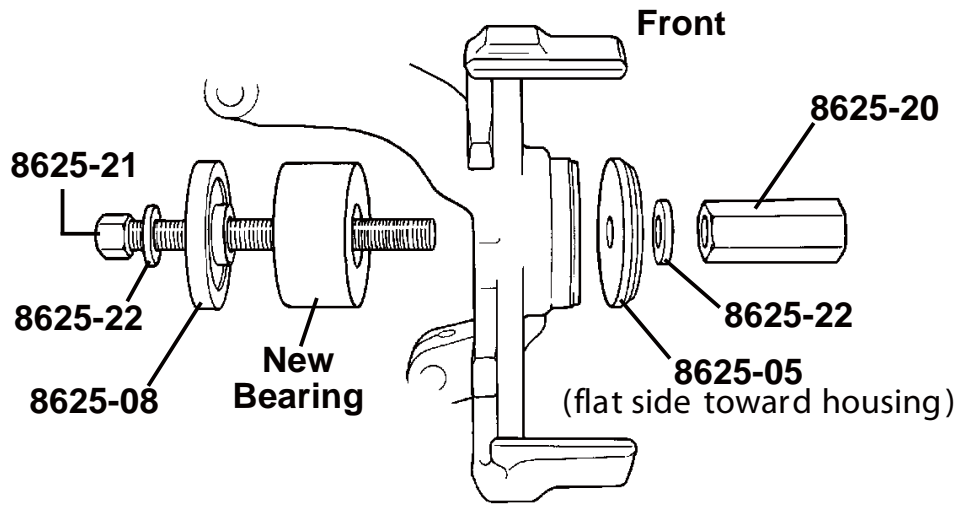

Figure 3

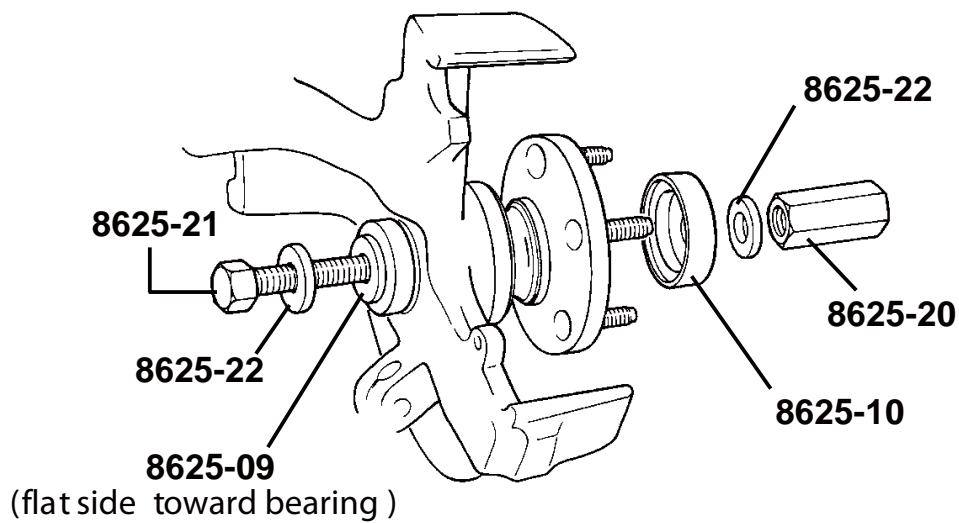

Figure 4

Acura

R= Remove I= Install	8625 -02	8625 -01	8625 -06	8625 -11	8625 -12	8625 -13	8625 -14	8625 -15	8625 -16	8625 -17	8625 -18	8625 -19	8625 -03	8625 -04	8625 -06	8625 -07	8625 -08	8625 -09	8625 -10
1986 Legend 1987 Legend(sedan) 1990-93 Integra 1991-03 NSX 1995-99 2.5TL 3.0CL 1996-99 2.2CL.2.3CL	R		RI							I								RI	I
1986-89 Integra			I	RI		I							R		R				I
1987 Legend(coupe) 1988-90 Legend 1992-94 Vigor		R	RI						I									RI	I
1991-99 Legend.3.2TC 1991-03 3.5RL 2002-03 RSX		R	RI									I						RI	I
1999-03 3.2		R	RI								I							RI	I
1994-01 Integra	R		RI							I								RI	I

Bearing Removal and Installation

1. Determine if the vehicle has a trapped rotor or a floating rotor.
2. Assemble tool components as shown in Figure 1.
3. Hold the forcing screw with a wrench, and press out the worn bearing as shown in Figure 2.

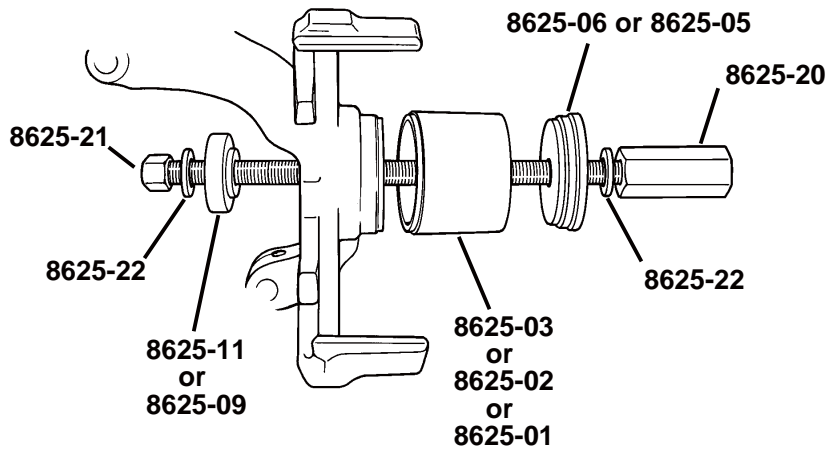

Figure 1

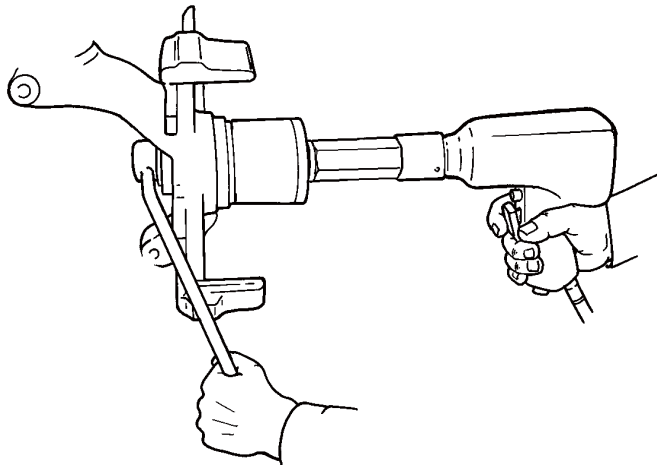

Figure 2

4. Lightly lubricate the new bearing, and position it for installation with the tool components assembled as shown in Figure 3.

Important: Assemble the adapter with the flat side toward the housing, and the small diameter pilot on the side away from the housing.

5. Press the bearing into the spindle assembly until it bottoms. Install the snap ring.

6. Assemble tool components as shown in Figure 4, and install the hub.

Important: Assemble the bearing Installer with the flat side toward the bearing, and the small diameter pilot on the side away from the bearing.

7. Assemble the remaining vehicle components that were removed for bearing replacement:

- . Lower ball joint to steering knuckle assembly
- . Brake rotor
- . Disc brake caliper
- . Outer tie rod nut and tie rod
- . Axle nut
- . Front tires

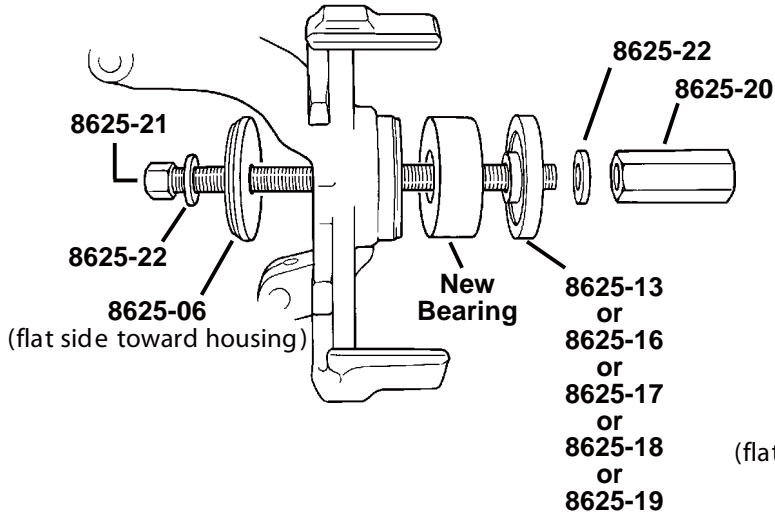

Figure 3

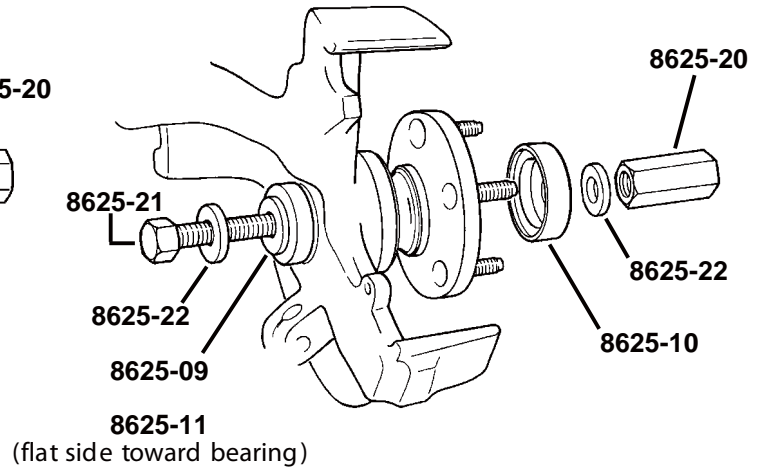

Figure 4

Audi

R= Remove I = Install	8625 -02	8625 -01	8625 -06	8625 -11	8625 -12	8625 -13	8625 -14	8625 -15	8625 -16	8625 -17	8625 -18	8625 -19	8625 -03	8625 -04	8625 -06	8625 -07	8625 -08	8625-09	8625 -10
1980-86 Quattro,5000, 5000 Quattro 1986-88 5000,5000 Quattro 1989-90 100,200(ATX) 1991 100,200(ATX 3 speed)			I					I					R		R			RI	I
1980-87 Coupe,4000 4000 Coupe 1988 80 series			I											R	R		I	RI	I
1988-94 Quattro (coupe). 80 series,80 Quattro, 90 series,90 Quattro			I					I					R		R		I	RI	I
1989-93 100,200(MTX) V8 Quattro,100 Quattro, 200 Quattro 1991 100,200(ATX4 speed) 1992-99 S4,V8 Quattro, 100 Quattro 1996-03 A4 1992-03A6,S6 1992-04,A8,Quattro	R		RI								I							RI	I
1996-02 A4 Exc Quattro		R	RI									I						RI	I

Bearing Removal and Installation

1. Determine if the vehicle has a trapped rotor or a floating rotor.
2. Assemble tool components as shown in Figure 1.
3. Hold the forcing screw with a wrench, and press out the worn bearing as shown in Figure 2.

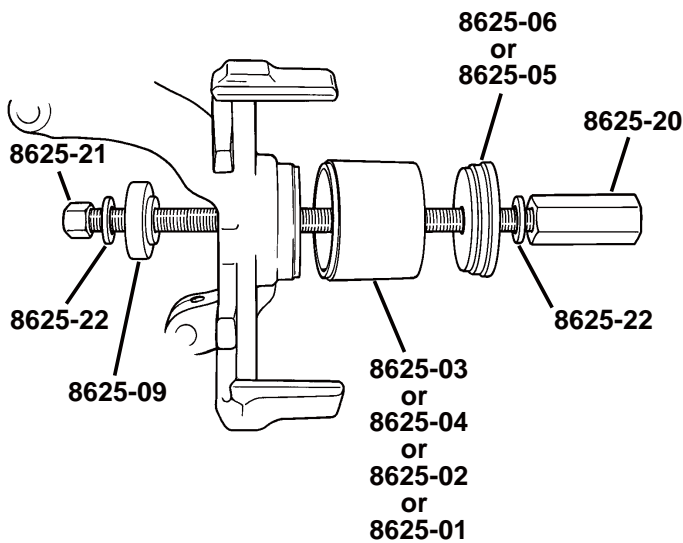

Figure 1

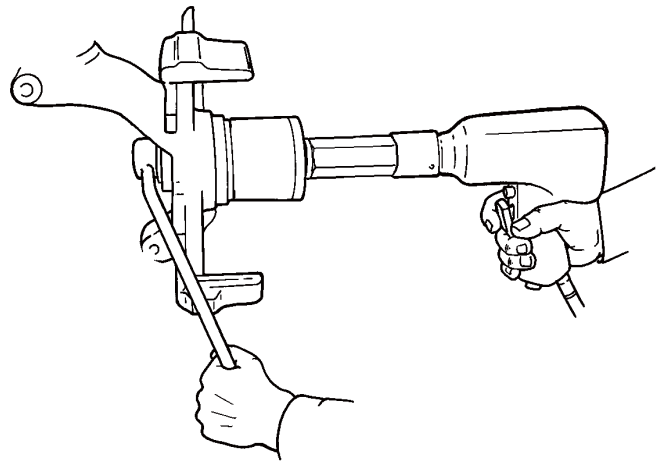

Figure 2

4. Lightly lubricate the new bearing, and position it for installation with the tool components assembled as shown in Figure 3.

Important: Assemble the adapter with the flat side toward the housing, and the small diameter pilot on the side away from the housing.

5. Press the bearing into the spindle assembly until it bottoms. Install the snap ring.

6. Assemble tool components as shown in Figure 4 to install the hub.

Important: Assemble the bearing installer with the flat side toward the bearing, and the small diameter pilot on the side away from the bearing.

7. Assemble the remaining vehicle components that were removed for bearing replacement:

- . Lower ball joint to steering knuckle assembly
- . Brake rotor
- . Disc brake caliper
- . Outer tie rod nut and tie rod
- . Axle nut
- . Front tires

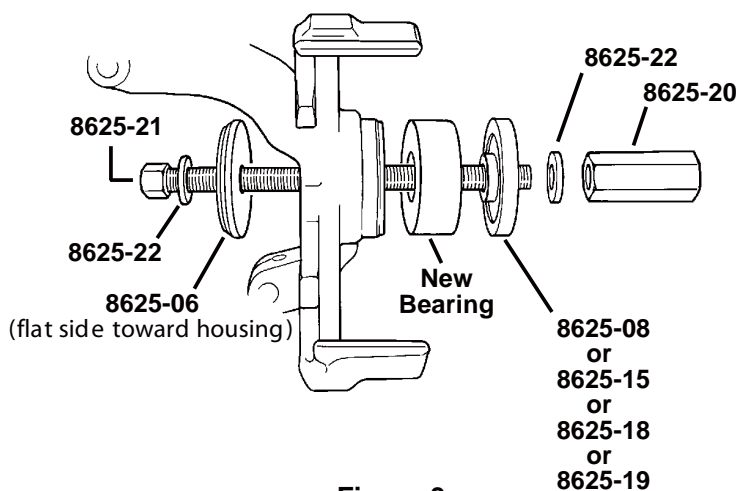

Figure 3

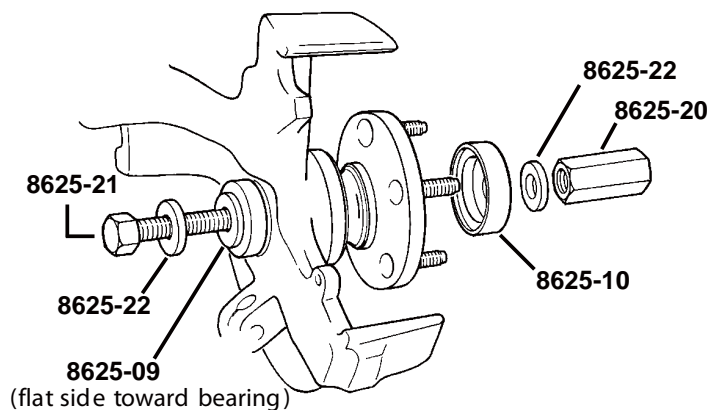

Figure 4

Eagle

R= Remove I = Install	8625-02	8625-01	8625-06	8625-11	8625-12	8625-13	8625-14	8625-15	8625-16	8625-17	8625-18	8625-19	8625-03	8625-04	8625-05	8625-07	8625-08	8625-09	8625-10
1993-96 Summit 1992-96 Summit Wagon 1990-94 Talon	R		RI													I		RI	I

Bearing Removal and Installation

1. Determine if the vehicle has a trapped rotor or a floating rotor.
2. Assemble tool components as shown in Figure 1.
3. Hold the forcing screw with a wrench, and press out the worn bearing as shown in Figure 2.

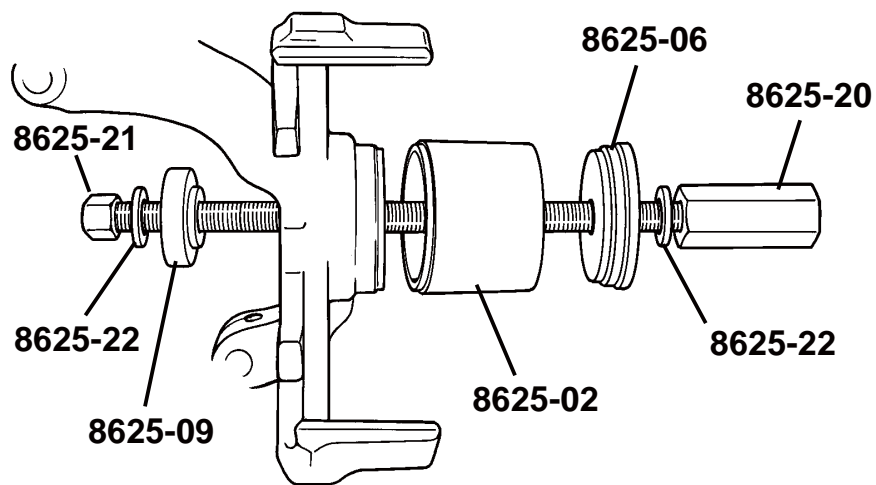

Figure 1

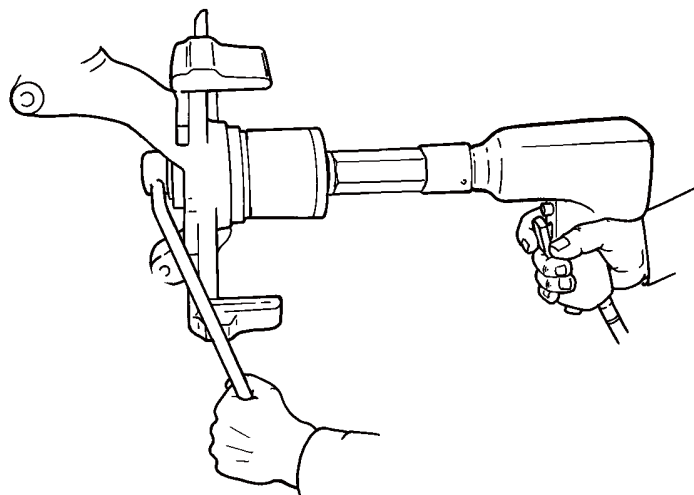

Figure 2

4. Lightly lubricate the new bearing, and position it for installation with the tool components assembled as shown in Figure 3.

Important: Assemble the adapter with the flat side toward the housing, and the small diameter pilot on the side away from the housing.

5. Press the bearing into the spindle assembly until it bottoms. Install the snap ring.

6. Assemble tool components as shown in Figure 4 to install the hub.

Important: Assemble the bearing installer with the flat side toward the bearing, and the small diameter pilot on the side away from the bearing.

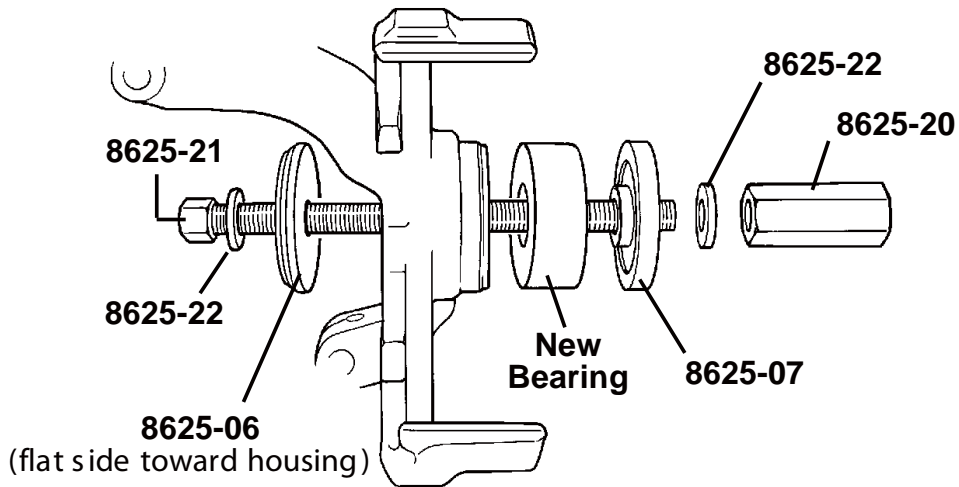

Figure 3

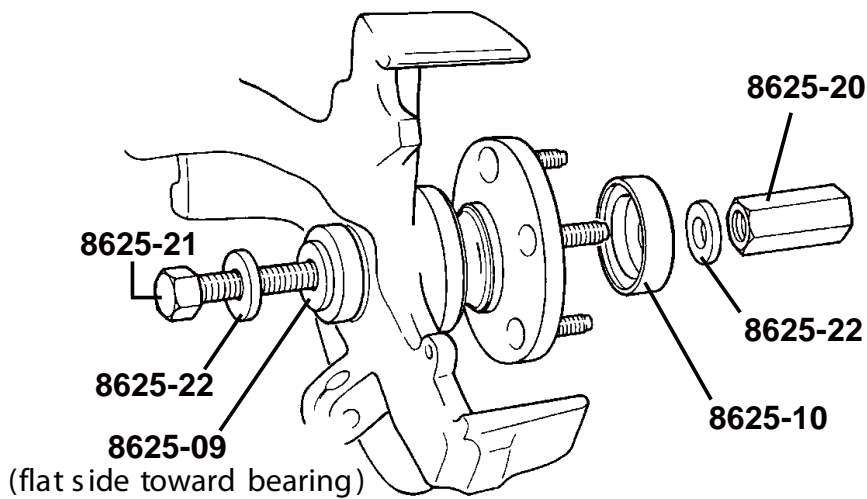

Figure 4

R= Remove I= Install	8625-02	8625-01	8625-06	8625-11	8625-12	8625-13	8625-14	8625-15	8625-16	8625-17	8625-18	8625-19	8625-03	8625-04	8625-06	8625-07	8625-08	8625-09	8625-10
1989-97 Prizm 1995-98 Metro														R	RI			RI	I

Bearing Removal and Installation

1. Determine if the vehicle has a trapped rotor or a floating rotor.
2. Assemble tool components as shown in Figure 1.
3. Hold the forcing screw with a wrench, and press out the worn bearing as shown in Figure 2.

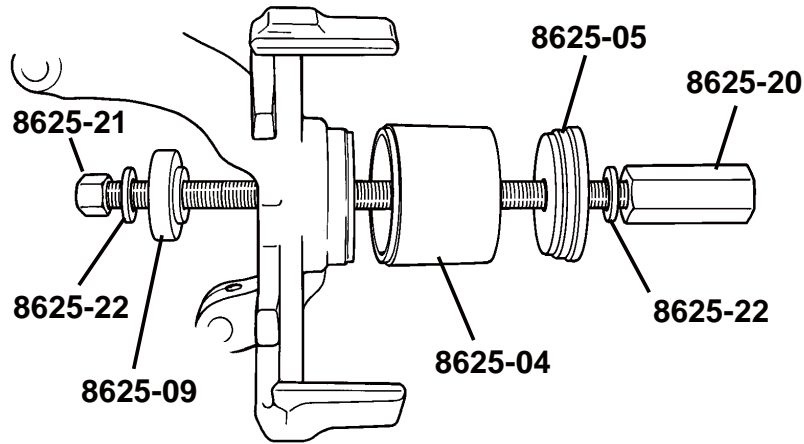

Figure 1

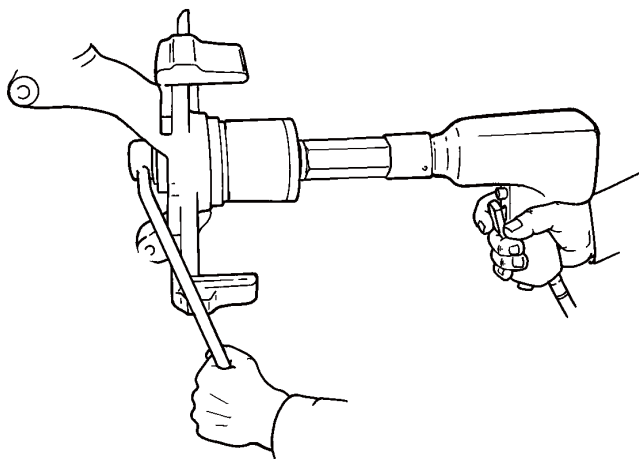

Figure 2

4. Lightly lubricate the new bearing, and position it for installation with the tool components assembled as shown in Figure 3.

Important: Assemble the adapter with the flat side toward the housing, and the small diameter pilot on the side away from the housing.

5. Press the bearing into the spindle assembly until it bottoms. Install the snap ring.

6. Assemble tool components as shown in Figure 4 to install the hub.

Important: Assemble the bearing installer with the flat side toward the bearing, and the small diameter pilot on the side away from the bearing.

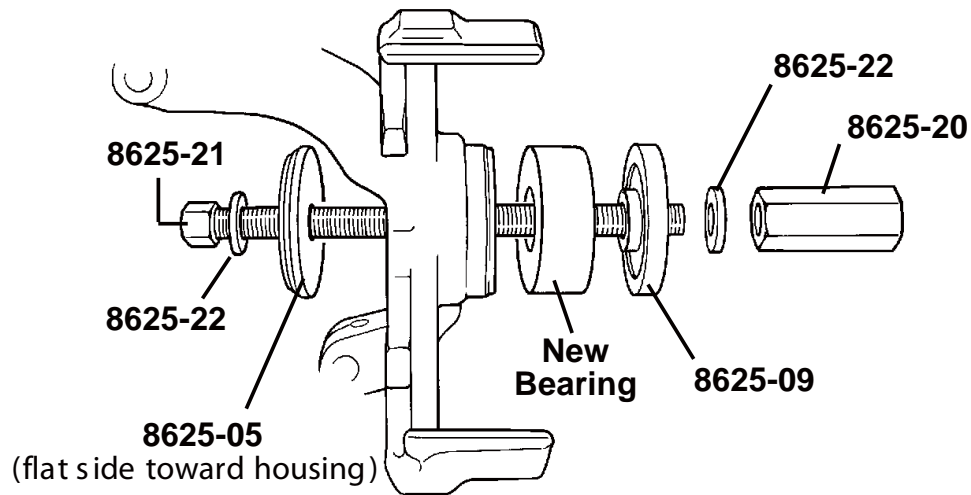

Figure 3

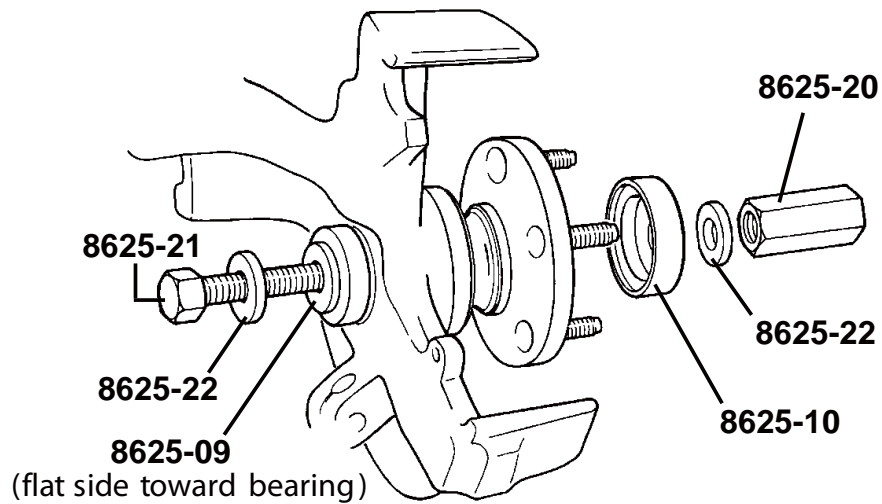

Figure 4

Honda

R= Remove I= Install	8625-02	8625-01	8625-06	8625-11	8625-12	8625-13	8625-14	8625-15	8625-16	8625-17	8625-18	8625-19	8625-03	8625-04	8625-05	8625-07	8625-08	8625-09	8625-10
1980-85 Accord 1980-87 Prelude				RI									R		RI				I
1984-91 Civic.CRX. Civic Wagon 4WD				I									R		RI			RI	I
1986-89 Accord 1992-99 Civic.del Sol						I							R		RI	I		RI	I
1988-96 Prelude	R		RI						I			I						RI	I
1996-00 Civic EXC.EX.Si						I							R		RI			RI	I
1992-96 Prelude 2003 Accord		R	RI									I						RI	I
2001-03 Civic 1996-00 Civic EX.Si 1994-97 del Sol 1992-95 Civic w/ABS	R		RI							I								RI	I
2000-03 S2000 1997-01 Prelude		R	RI									I						RI	I
1999-03 Odyssey		R	RI						I									RI	I
1998-02 Accord		R	RI									I						RI	I

Bearing Removal and Installation

1. Determine if the vehicle has a trapped rotor or a floating rotor.

Note: Some Honda vehicles use a bolt-in bearing instead of a pressed-in bearing. Refer to Hub Tamer Instructions-Trapped Rotors to service these bearings.

2. Assemble tool components as shown in Figure 1.

3. Hold the forcing screw with a wrench, and press out the worn bearing as shown in Figure 2.

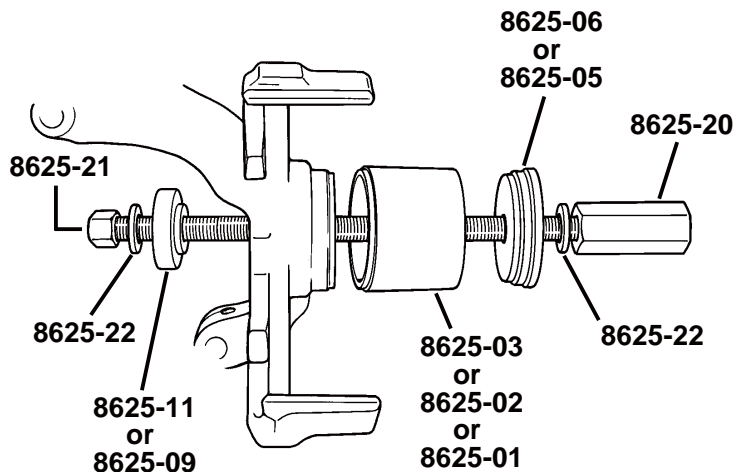

Figure 1

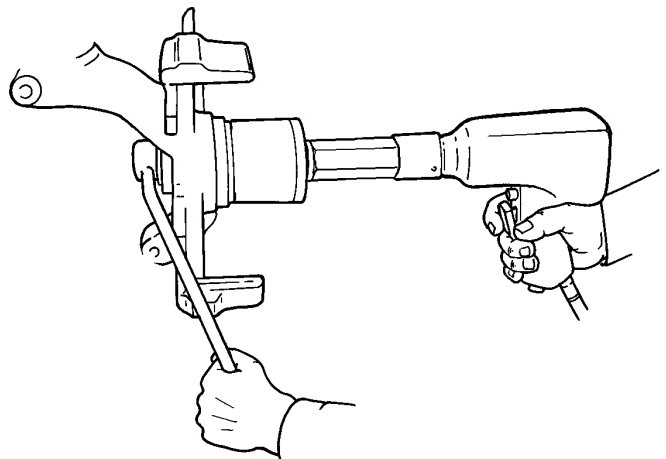

Figure 2

4. Lightly lubricate the new bearing, and position it for installation with the tool components assembled as shown in Figure 3.

Important: Assemble the adapter with the flat side toward the housing, and the small diameter pilot on the side away from the housing.

5. Press the bearing into the spindle assembly until it bottoms. Install the snap ring.

6. Assemble tool components as shown in Figure 4, and install the hub.

Important: Assemble the bearing installer with the flat side toward the bearing, and the small diameter pilot on the side away from the bearing.

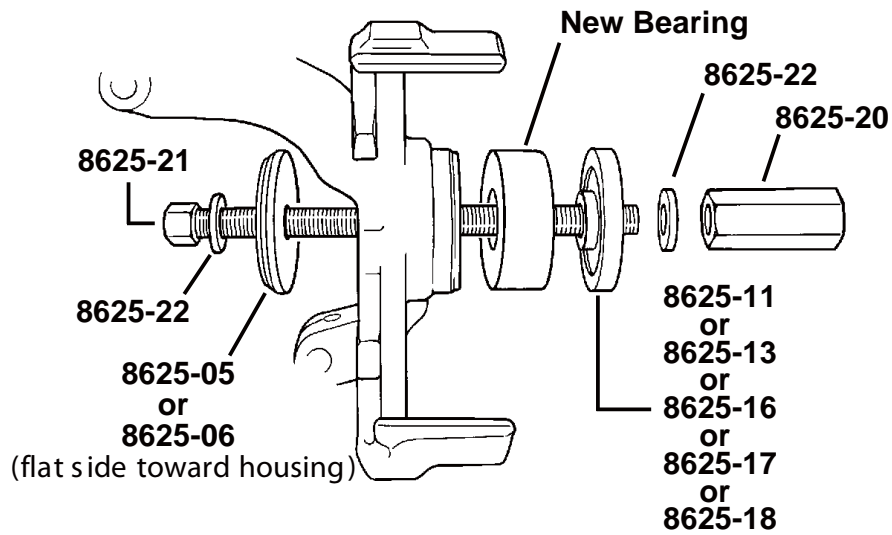

Figure 3

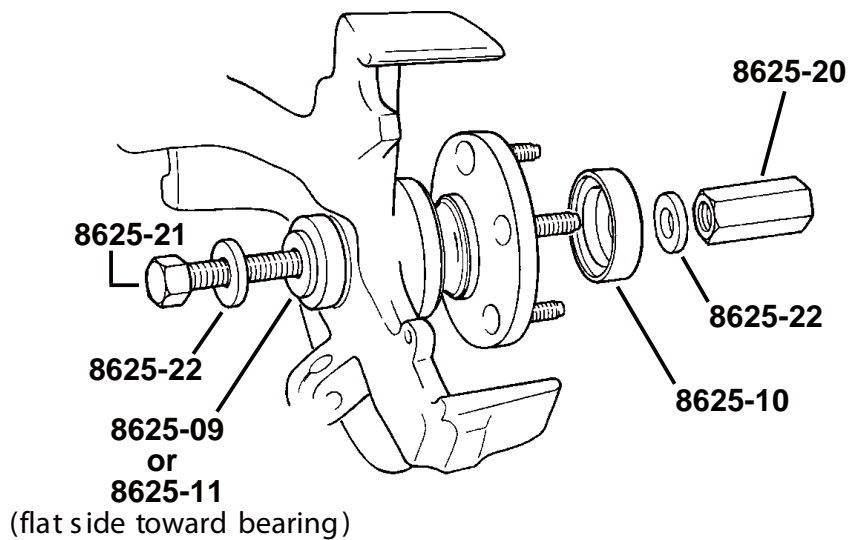

Figure 4

Hyundai

R= Remove I= Install	8625 -02	8625 -01	8625 -06	8625 -11	8625 -12	8625 -13	8625 -14	8625 -15	8625 -16	8625 -17	8625 -18	8625 -19	8625 -03	8625 -04	8625 -05	8625 -07	8625 -08	8625 -09	8625 -10
1986-95 Elantra, Scoupe 1995-1999 Accent					I								R		RI			RI	I
1989-94 Sonata		R	RI							I								RI	I
2001-02 Sonata		R	RI									I						RI	I
1999-02 Sonata	R		RI							I								RI	I
2000-02 Accent 1996-02 Elantra 1997-01 Tiburon													R		RI		I	RI	I

Bearing Removal and Installation

1. Determine if the vehicle has a trapped rotor or a floating rotor.
2. Assemble tool components as shown in Figure 1.
3. Hold the forcing screw with a wrench, and press out the worn bearing as shown in Figure 2.

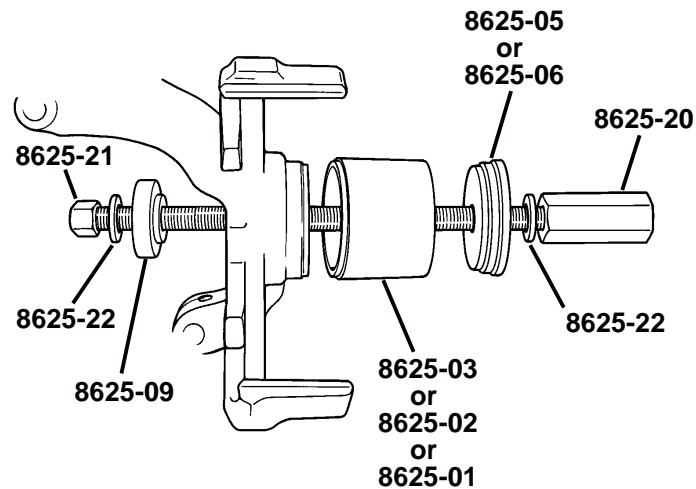

Figure 1

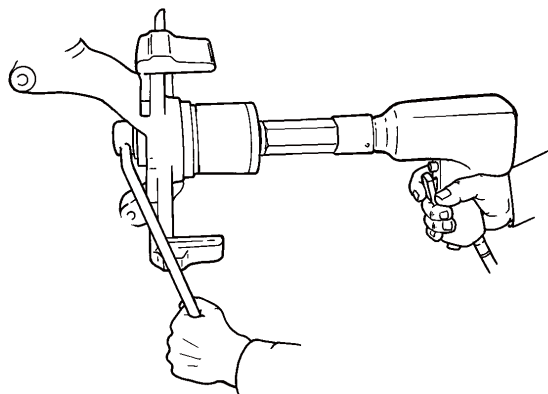

Figure 2

4. Lightly lubricate the new bearing, and position it for installation with the tool components assembled as shown in Figure 3.

Important: Assemble the adapter with the flat side toward the housing, and the small diameter pilot on the side away from the housing.

5. Press the bearing into the spindle assembly until it bottoms. Install the snap ring.

6. Assemble tool components as shown in Figure 4, and install the hub.

Important: Assemble the bearing installer with the flat side toward the bearing, and the small diameter pilot on the side away from the bearing.

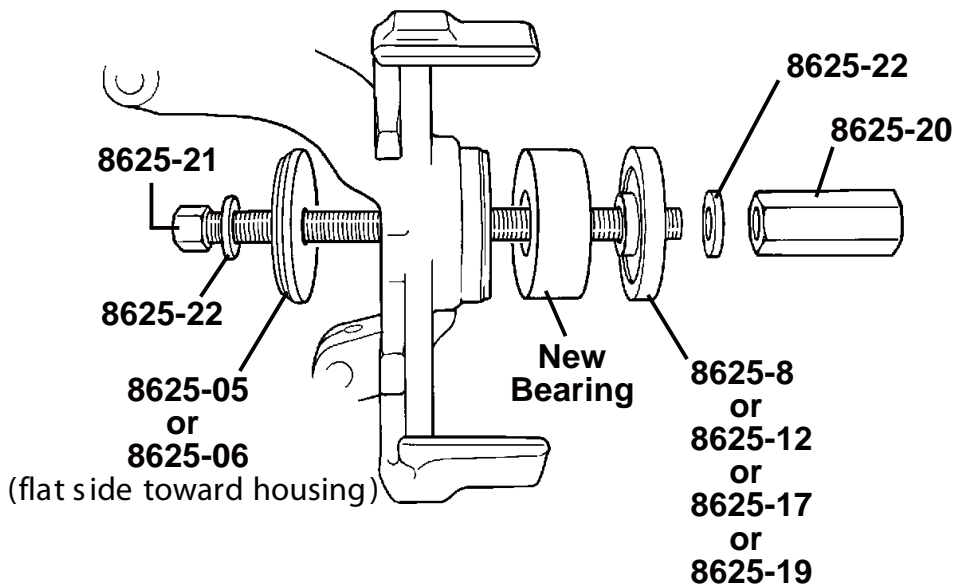

Figure 3

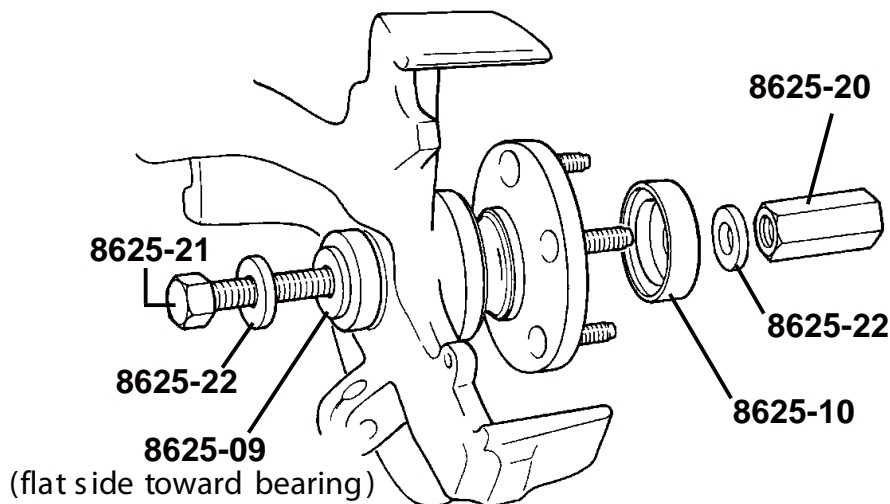

Figure 4

R= Remove I= Install	8625-02	8625-01	8625-06	8625-11	8625-12	8625-13	8625-14	8625-15	8625-16	8625-17	8625-18	8625-19	8625-03	8625-04	8625-05	8625-07	8625-08	8625-09	8625-10
1991-02 G20 1996-01 130								I					R		RI			RI	I

Bearing Removal and Installation

1. Determine if the vehicle has a trapped rotor or a floating rotor.
2. Assemble tool components as shown in Figure 1.
3. Hold the forcing screw with a wrench, and press out the worn bearing as shown in Figure 2.

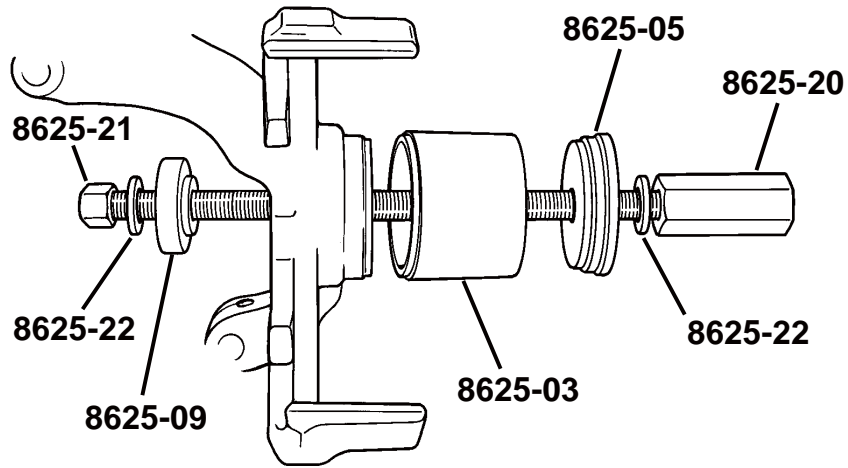

Figure 1

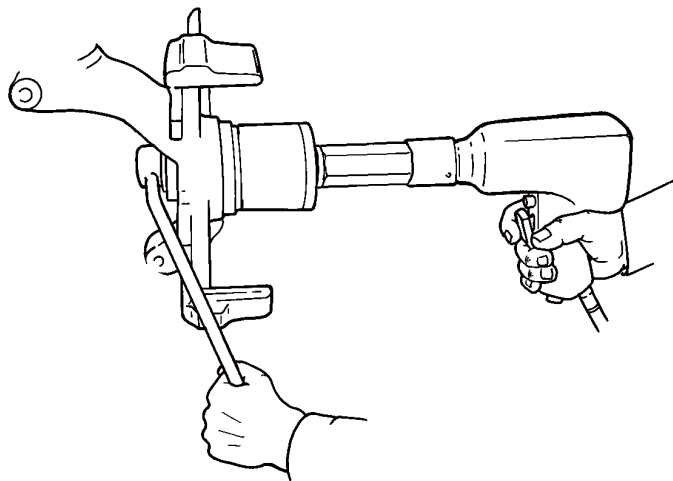

Figure 2

4. Lightly lubricate the new bearing, and position it for installation with the tool components assembled as shown in Figure 3.

Important: Assemble the adapter with the flat side toward the housing, and the small diameter pilot on the side away from the housing.

5. Press the bearing into the spindle assembly until it bottoms. Install the snap ring.

6. Assemble tool components as shown in Figure 4, and install the hub.

Important: Assemble the bearing Installer with the flat side toward the bearing, and the small diameter pilot on the side away from the bearing.

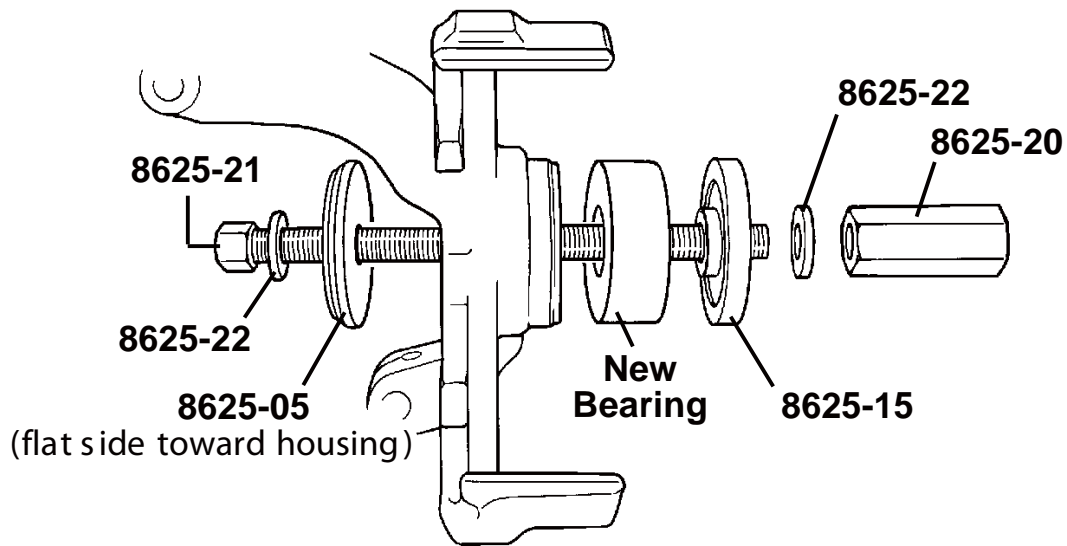

Figure 3

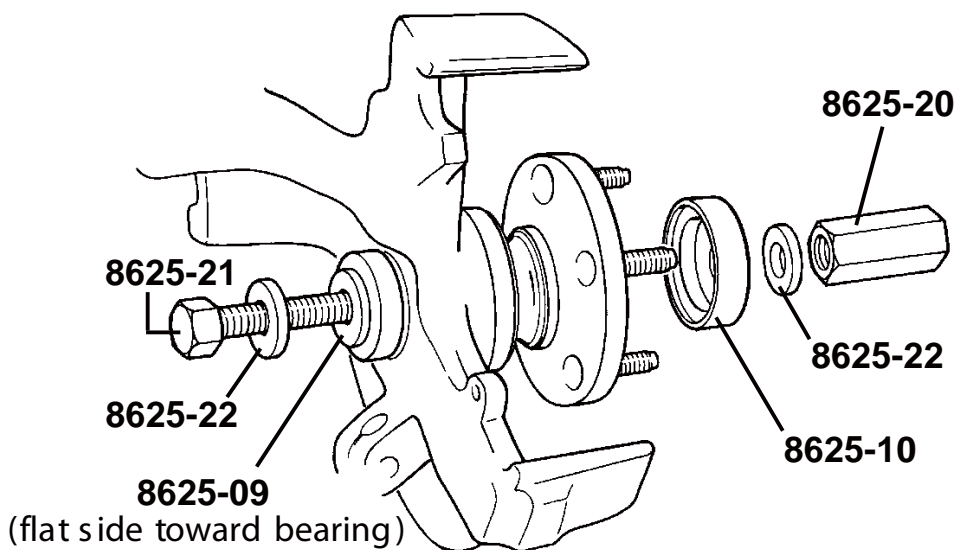

Figure 4

Lexus

R= Remove I= Install	8625 -2	8625 -1	8625 -6	8625 -11	8625 -12	8625 -13	8625 -14	8625 -15	8625 -16	8625 -17	8625 -18	8625 -19	8625 -3	8625 -4	8625 -5	8625 -7	8625 -8	8625 -9	8625 -10
1989-91 ES250					I	I		I					R		RI			RI	I
192-02 ES300	R		RI								I							RI	I

Bearing Removal and Installation

1. Determine if the vehicle has a trapped rotor or a floating rotor.
2. Assemble tool components as shown in Figure 1.
3. Hold the forcing screw with a wrench, and press out the worn bearing as shown in Figure 2.

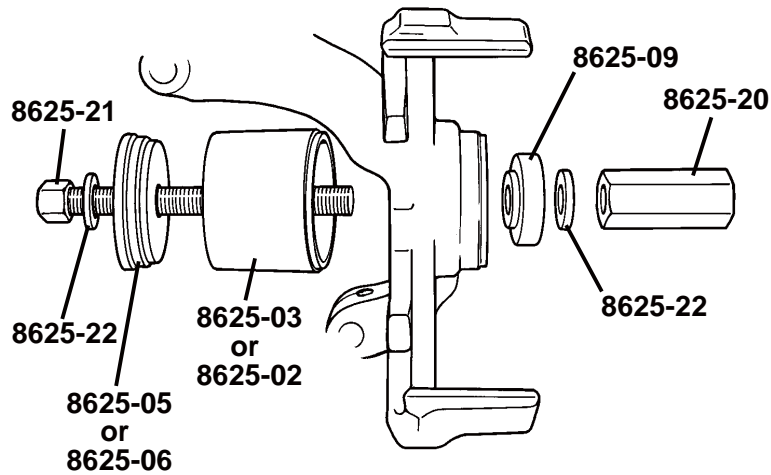

Figure 1

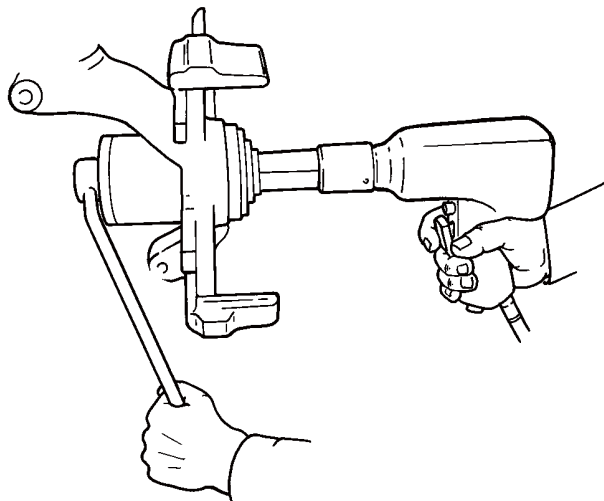

Figure 2

4. Lightly lubricate the new bearing, and position it for installation with the tool components assembled as shown in Figure 3.

Important: Assemble the adapter with the flat side toward the housing, and the small diameter pilot on the side away from the housing.

5. Press the bearing into the spindle assembly until it bottoms. Install the snap ring.

6. Assemble tool components as shown in Figure 4, and install the hub.

Important: Assemble the bearing installer with the flat side toward the bearing, and the small diameter pilot on the side away from the bearing.

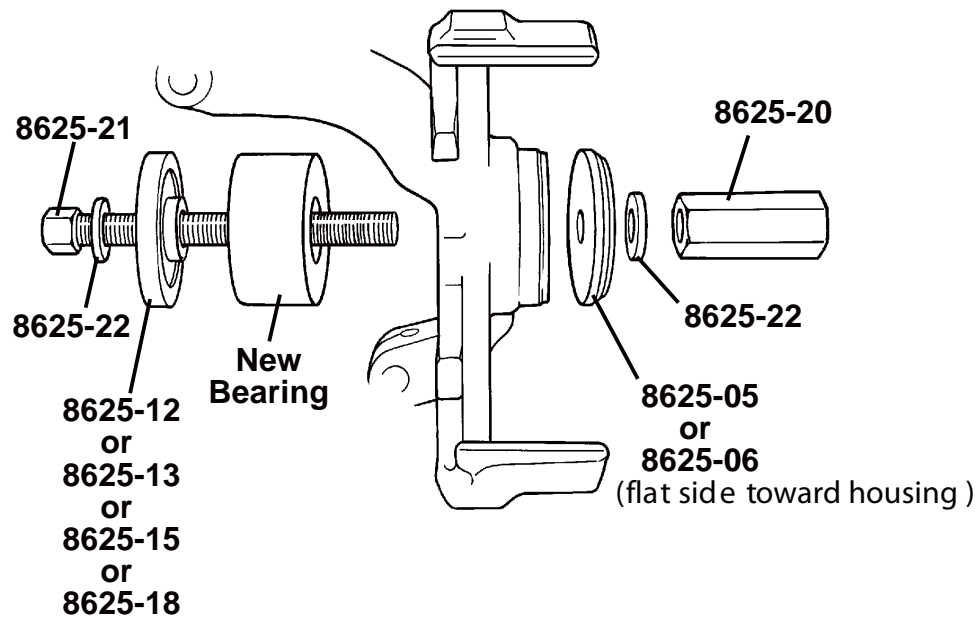

Figure 3

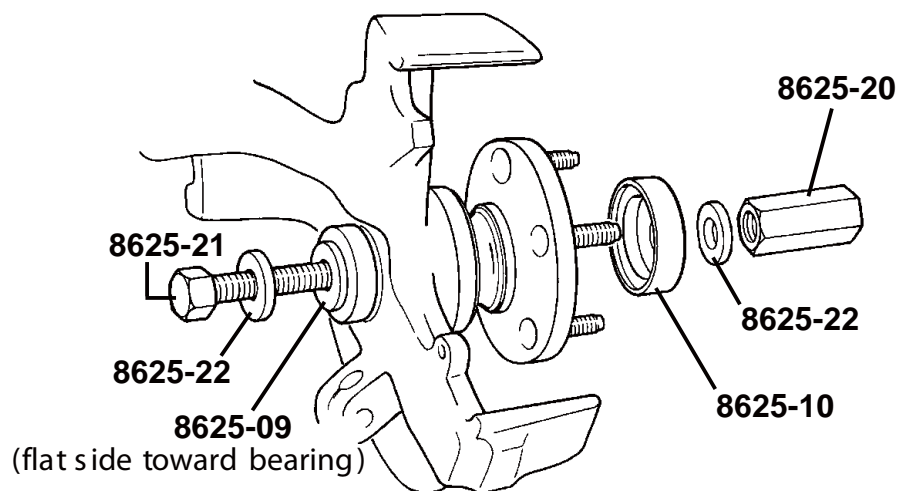

Figure 4

Mazda

R= Remove I = Install	8625 -02	8625 -01	8625 -06	8625 -11	8625 -12	8625 -13	8625 -14	8625 -15	8625 -16	8625 -17	8625 -18	8625 -19	8625 -03	8625 -04	8625 -05	8625 -07	8625 -08	8625 -09	8625 -10
1983-87 626														R	RI		I	RI	I
1988-92 MX6,626							I						R		RI			RI	I
1990-99 MX3, Protege. 323								I					R		RI			RI	I
1990-99 Millenia, MX6. 626	R		RI							I								RI	I
1993-03 626 MX6 1996-00 Millenia										I			R		RI			RI	I
1988-02 Protege								I					R		RI			RI	I

Bearing Removal and Installation

1. Determine if the vehicle has a trapped rotor or a floating rotor.
2. Assemble tool components as shown in Figure 1.
3. Hold the forcing screw with a wrench, and press out the worn bearing as shown in Figure 2.

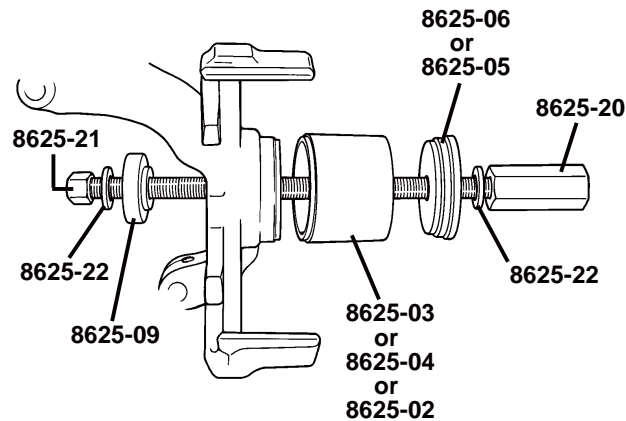

Figure 1

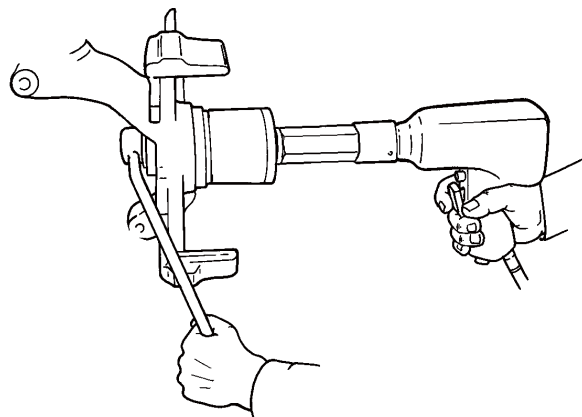

Figure 2

4. Lightly lubricate the new bearing, and position it for installation with the tool components assembled as shown in Figure 3.

Important: Assemble the adapter with the flat side toward the housing, and the small diameter pilot on the side away from the housing.

5. Press the bearing into the spindle assembly until it bottoms. Install the snap ring.

6. Assemble tool components as shown in Figure 4, and install the hub.

Important: Assemble the bearing installer with the flat side toward the bearing, and the small diameter pilot on the side away from the bearing.

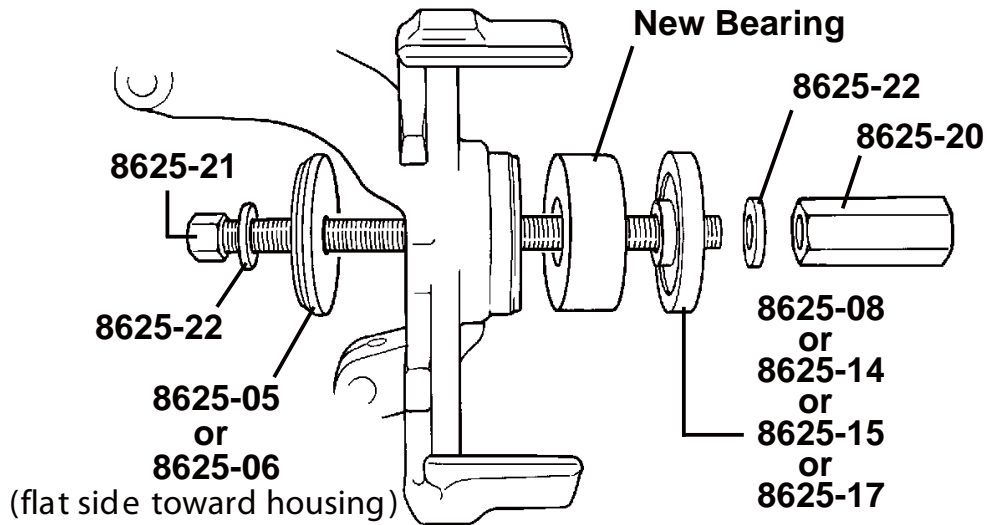

Figure 3

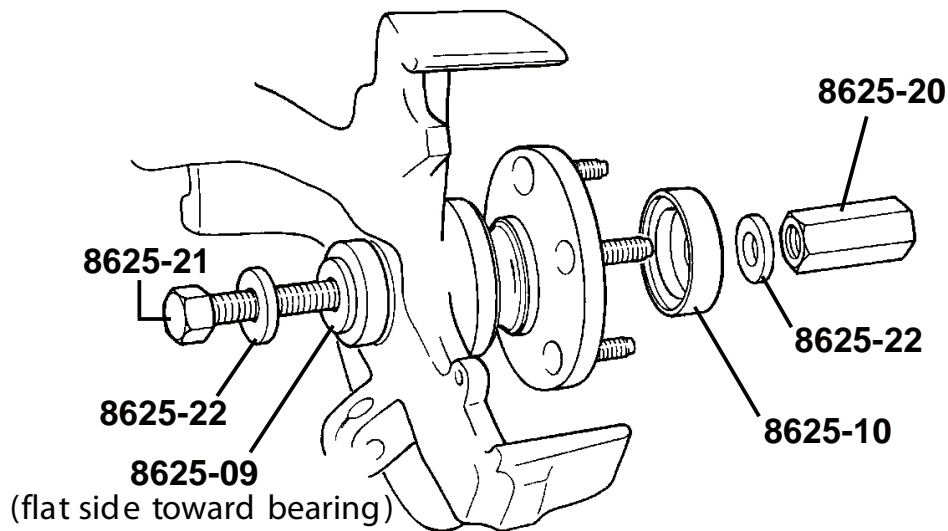

Figure 4

Mitsubishi

R= Remove I= Install	8625 -02	8625 -01	8625 -06	8625 -11	8625 -12	8625 -13	8625 -14	8625 -15	8625 -16	8625 -17	8625 -18	8625 -19	8625 -03	8625 -04	8625 -05	8625 -07	8625 -08	8625 -09	8625 -10
1990-03 Diamante 1992-02 Mirage 1989-94 Eclipse 1985-93 Galant, Sigma 1999 3000GT		R	RI													I		RI	I

Bearing Removal and Installation

1. Determine if the vehicle has a trapped rotor or a floating rotor.
2. Assemble tool components as shown in Figure 1.
3. Hold the forcing screw with a wrench, and press out the worn bearing as shown in Figure 2.

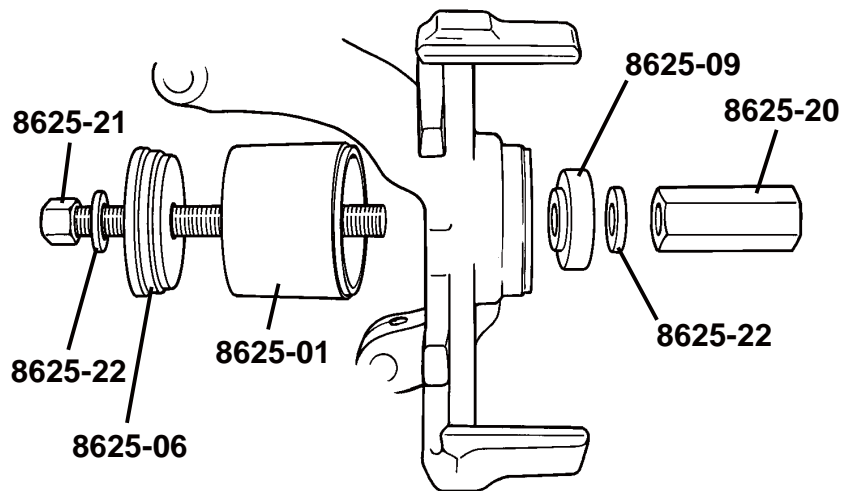

Figure 1

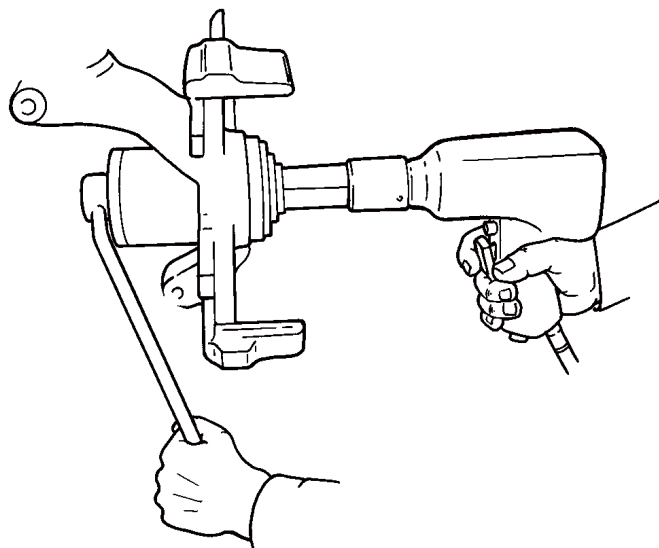

Figure 2

4. Lightly lubricate the new bearing, and position it for installation with the tool components assembled as shown in Figure 3.

Important: Assemble the adapter with the flat side toward the housing, and the small diameter pilot on the side away from the housing.

5. Press the bearing into the spindle assembly until it bottoms. Install the snap ring.

6. Assemble tool components as shown in Figure 4, and install the hub.

Important: Assemble the bearing installer with the flat side toward the bearing, and the small diameter pilot on the side away from the bearing.

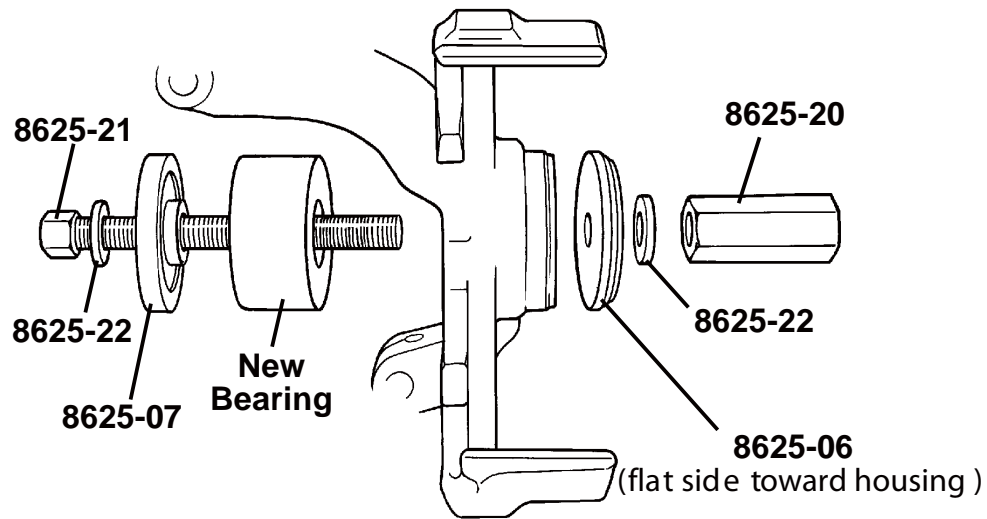

Figure 3

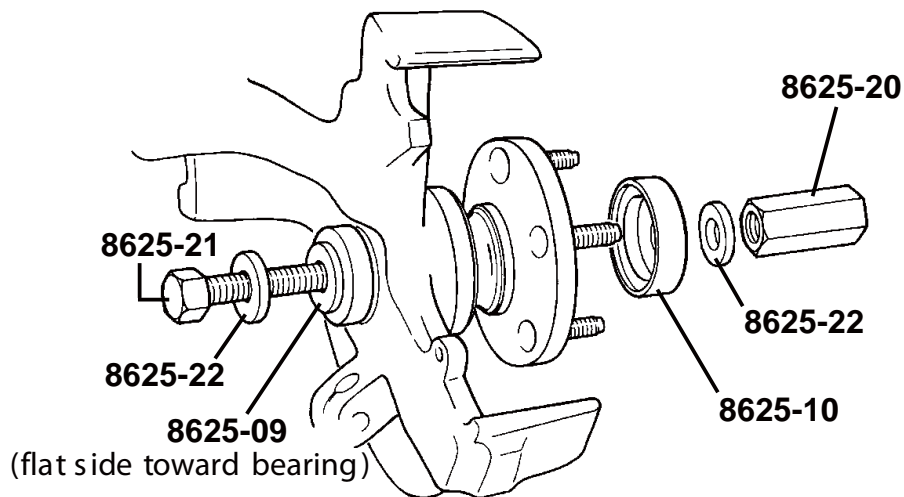

Figure 4

Nissan

R= Remove I= Install	8625-02	8625-01	8625-06	8625-11	8625-12	8625-13	8625-14	8625-15	8625-16	8625-17	8625-18	8625-19	8625-03	8625-04	8625-05	8625-07	8625-08	8625-09	8625-10
1987-90 Pulsar. Sentra 1991-99 NX. Sentra.200 SX					RI			I					R		RI				I
1989 Maxima 1990-99 Altima, Maxima, Stanza 2000-01 Altima 2000-03 Sentra								I					R		RI			RI	I
1985-88 Maxima, Maxima Wagon 1985-88 Stanza. Stanza Wagon 1989 Stanza							I						R		RI			RI	I

Bearing Removal and Installation

1. Determine if the vehicle has a trapped rotor or a floating rotor.
2. Assemble tool components as shown in Figure 1.
3. Hold the forcing screw with a wrench, and press out the worn bearing as shown in Figure 2.

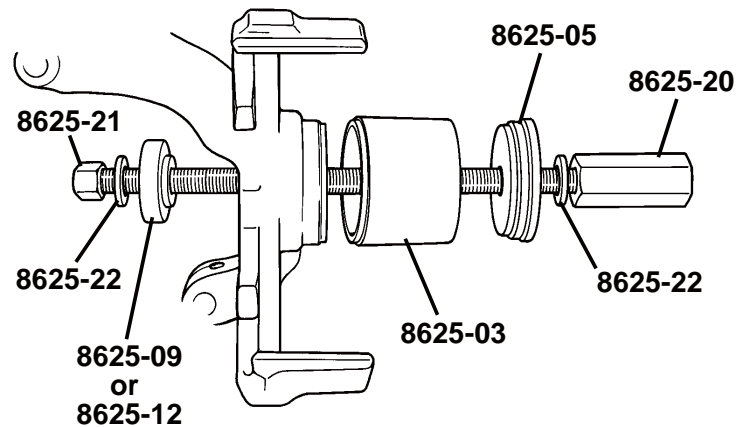

Figure 1

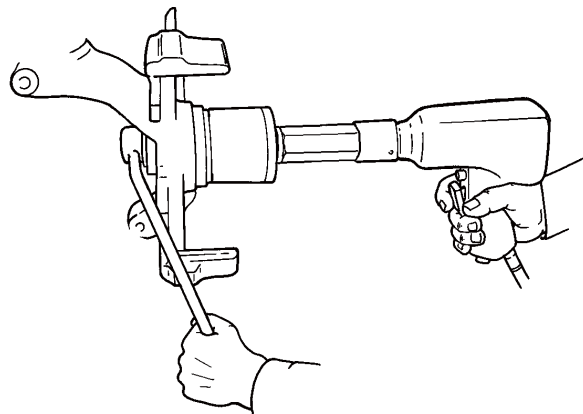

Figure 2

4. Lightly lubricate the new bearing, and position it for installation with the tool components assembled as shown in Figure 3.

Important: Assemble the adapter with the flat side toward the housing, and the small diameter pilot on the side away from the housing.

5. Press the bearing into the spindle assembly until it bottoms. Install the snap ring.

6. Assemble tool components as shown in Figure 4, and install the hub.

Important: Assemble the bearing installer with the flat side toward the bearing, and the small diameter pilot on the side away from the bearing.

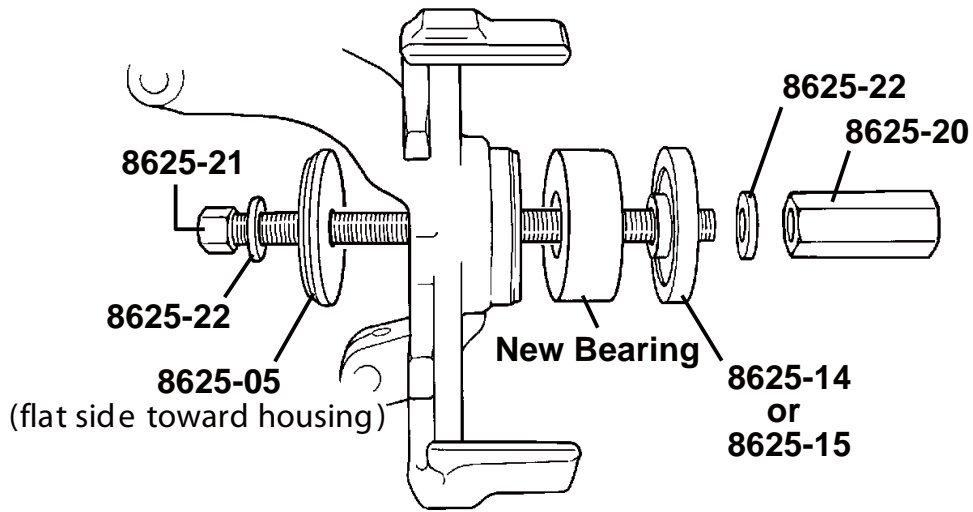

Figure 3

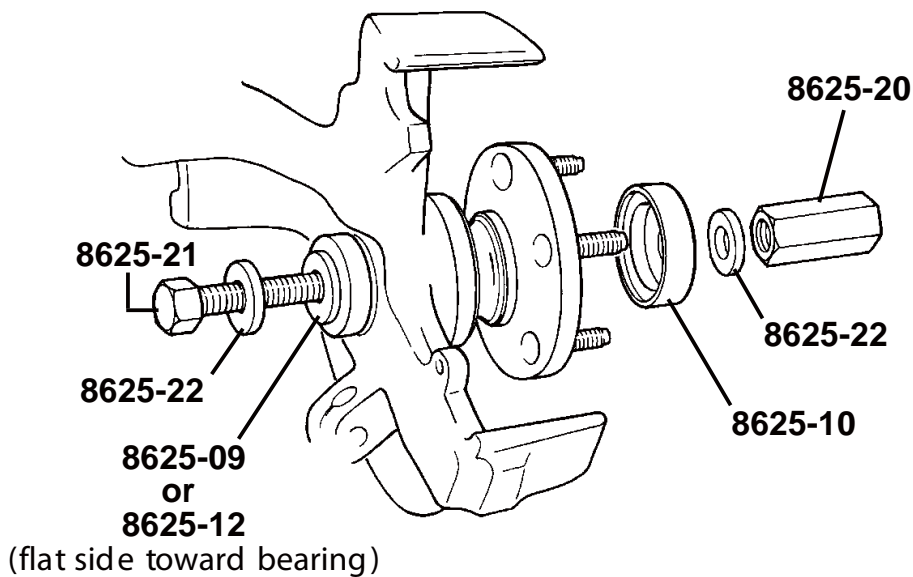

Figure 4

Subaru

R= Remove I= Install	8625 -02	8625 -01	8625 -06	8625 -11	8625 -12	8625 -13	8625 -14	8625 -15	8625 -16	8625 -17	8625 -18	8625 -19	8625 -03	8625 -04	8625 -05	8625 -07	8625 -08	8625 -09	8625 -10
1994-03 Legacy 1993-03 Impreza 1992-98 XVX					I								R		RI			RI	I

Bearing Removal and Installation

1. Determine if the vehicle has a trapped rotor or a floating rotor.
2. Assemble tool components as shown in Figure 1.
3. Hold the forcing screw with a wrench, and press out the worn bearing as shown in Figure 2.

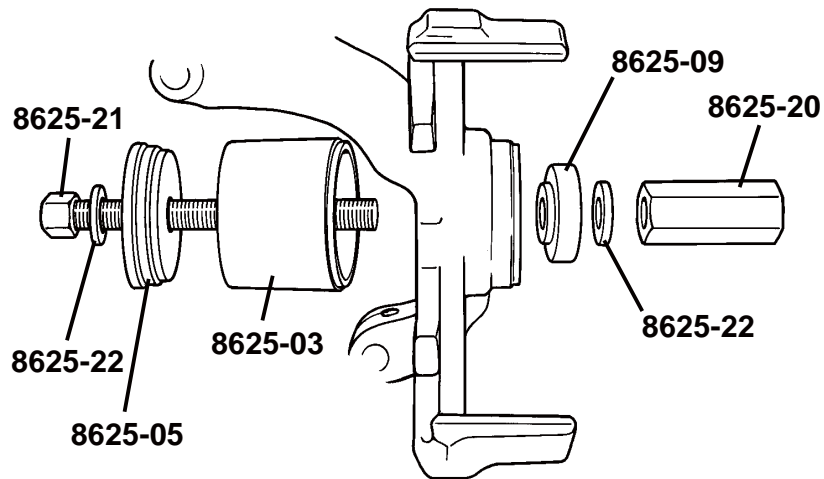

Figure 1

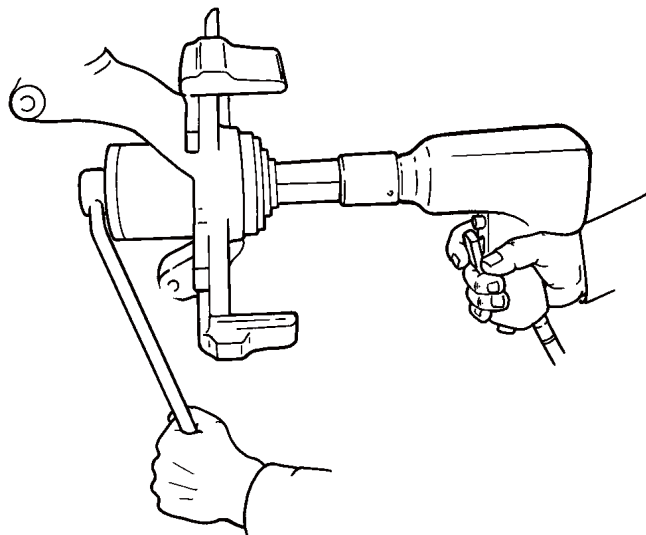

Figure 2

4. Lightly lubricate the new bearing, and position it for installation with the tool components assembled as shown in Figure 3.

Important: Assemble the adapter with the flat side toward the housing, and the small diameter pilot on the side away from the housing.

5. Press the bearing into the spindle assembly until it bottoms. Install the snap ring.

6. Assemble tool components as shown in Figure 4, and install the hub.

Important: Assemble the bearing installer with the flat side toward the bearing, and the small diameter pilot on the side away from the bearing.

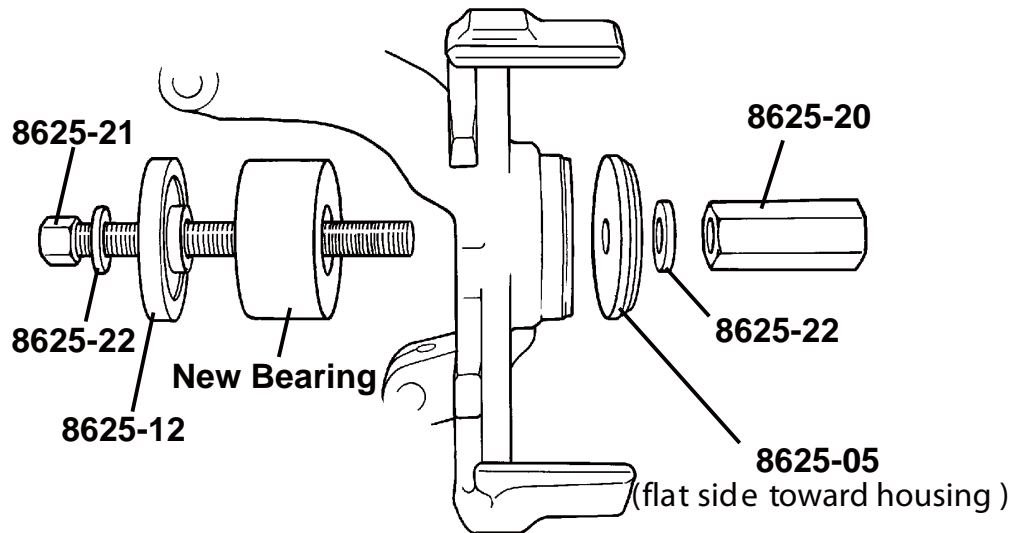

Figure 3

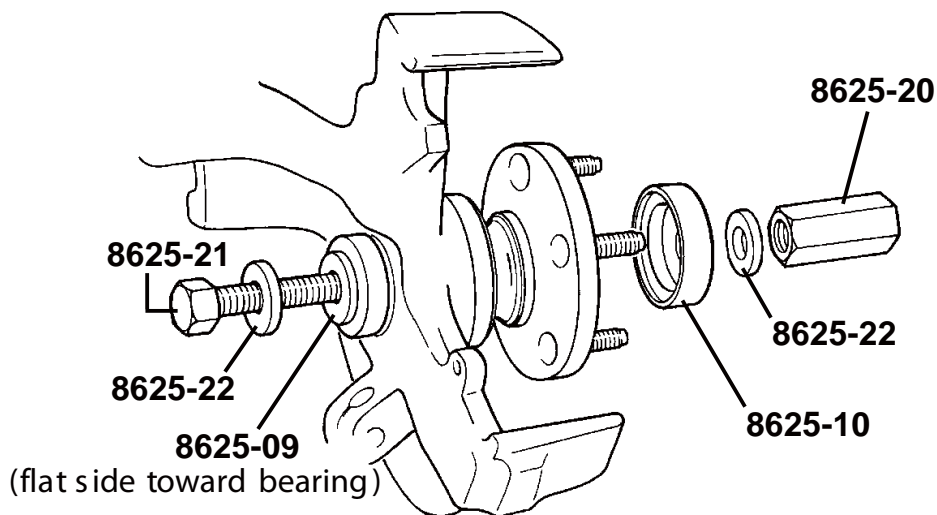

Figure 4

Toyota

R= Remove I= Install	8625 -02	8625 -01	8625 -06	8625 -11	8625 -12	8625 -13	8625 -14	8625 -15	8625 -16	8625 -17	8625 -18	8625 -19	8625 -03	8625 -04	8625 -05	8625 -07	8625 -08	8625 -09	8625 -10
1983-89 Corolla FX 1983-91 Camry 1983-99 Celica 1983-99 Tercel 1987-99 Paseo 1988-02 Corolla					I	I		I					R		RI			RI	I
1992-03 Avalon, Camry	R		RI								I							RI	I
2003 Corolla 2001-03 Prius								I					R		RI			RI	I
2000-03 Echo 2000 Celica					I								R		RI			RI	I

Bearing Removal and Installation

1. Determine if the vehicle has a trapped rotor or a floating rotor.
2. Assemble tool components as shown in Figure 1.
3. Hold the forcing screw with a wrench, and press out the worn bearing as shown in Figure 2.

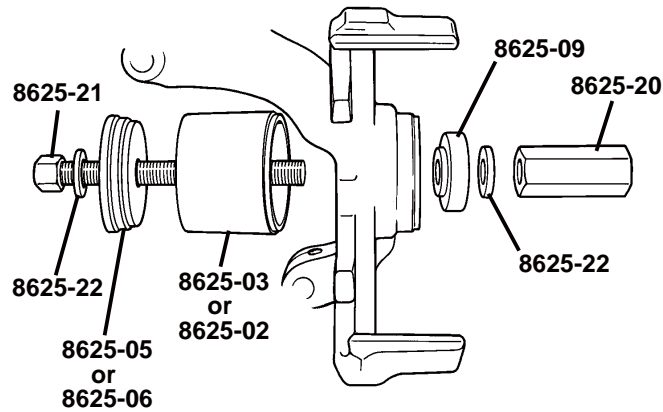

Figure 1

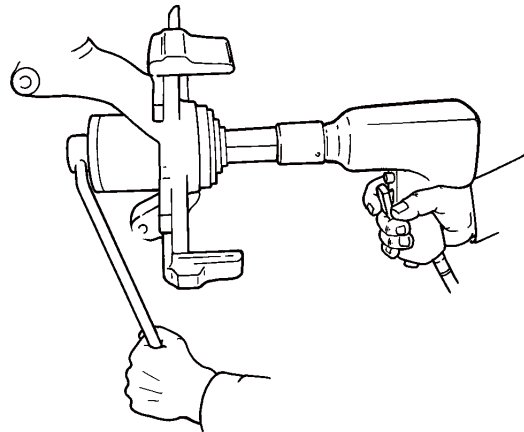

Figure 2

4. Lightly lubricate the new bearing, and position it for installation with the tool components assembled as shown in Figure 3.

Important: Assemble the adapter with the flat side toward the housing, and the small diameter pilot on the side away from the housing.

5. Press the bearing into the spindle assembly until it bottoms. Install the snap ring.

6. Assemble tool components as shown in Figure 4, and install the hub.

Important: Assemble the bearing installer with the flat side toward the bearing, and the small diameter pilot on the side away from the bearing.

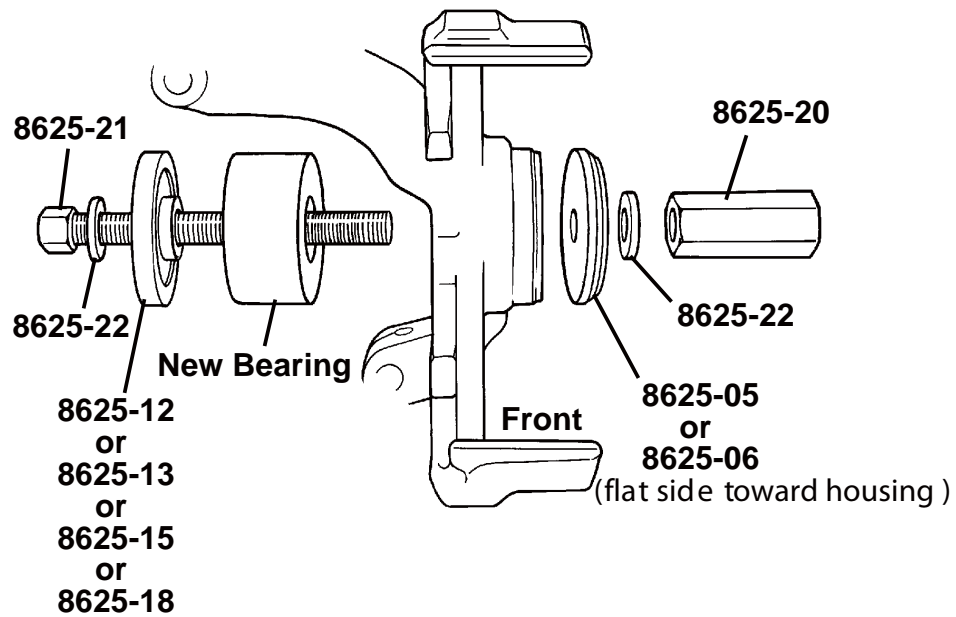

Figure 3

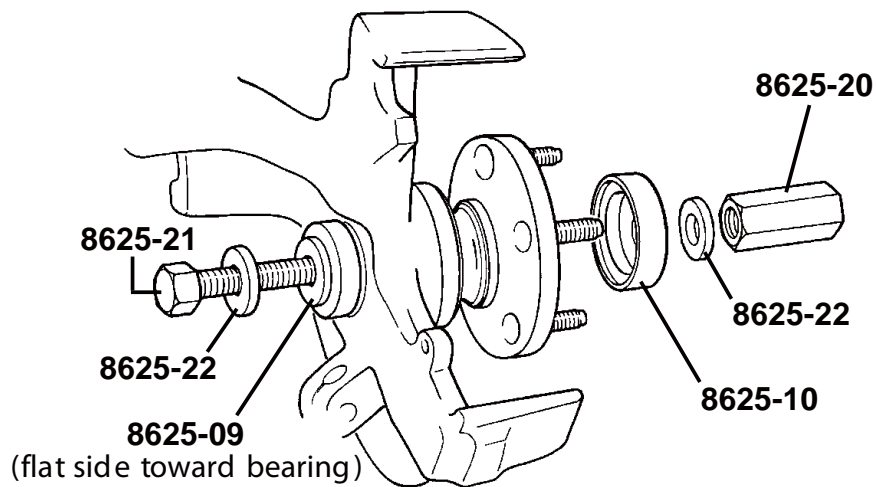

Figure 4

Volkswagen

R= Remove I= Install	8625 -02	8625 -01	8625 -06	8625 -11	8625 -12	8625 -13	8625 -14	8625 -15	8625 -16	8625 -17	8625 -18	8625 -19	8625 -03	8625 -04	8625 -05	8625 -07	8625 -08	8625 -09	8625 -10
1980-84 Jetta, Rabbit 1980-96 Scirocco 1985-87 Golf, GTL, Jetta 1985-96 Cabriolet				RI										R	RI		I		I
1980-96 Dasher, Fox, Quantum, Quantum Synchro				I										R	RI			RI	I
1988-02 Golf, GTI, Jetta 1990-89 Corrado, Passat						I							R		RI			RI	I
1998-03 Passat 1992-96 Eurovan	R		RI															RI	I

Bearing Removal and Installation

1. Determine if the vehicle has a trapped rotor or a floating rotor.
2. Assemble tool components as shown in Figure 1.
3. Hold the forcing screw with a wrench, and press out the worn bearing as shown in Figure 2.

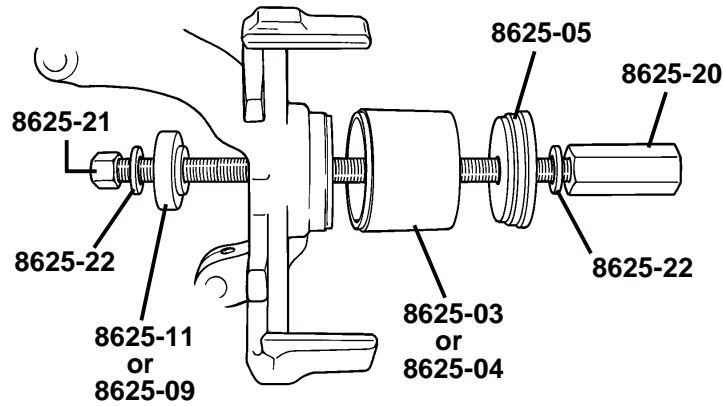

Figure 1

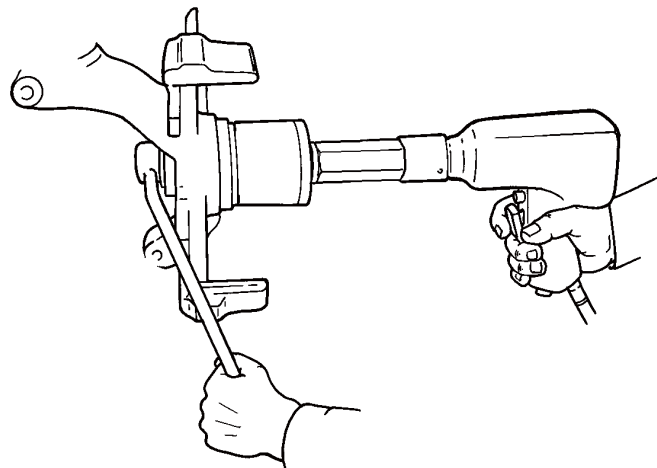

Figure 2

4. Lightly lubricate the new bearing, and position it for installation with the tool components assembled as shown in Figure 3.

Important: Assemble the adapter with the flat side toward the housing, and the small diameter pilot on the side away from the housing.

5. Press the bearing into the spindle assembly until it bottoms. Install the snap ring.

6. Assemble tool components as shown in Figure 4, and install the hub.

Important: Assemble the bearing installer with the flat side toward the bearing, and the small diameter pilot on the side away from the bearing.

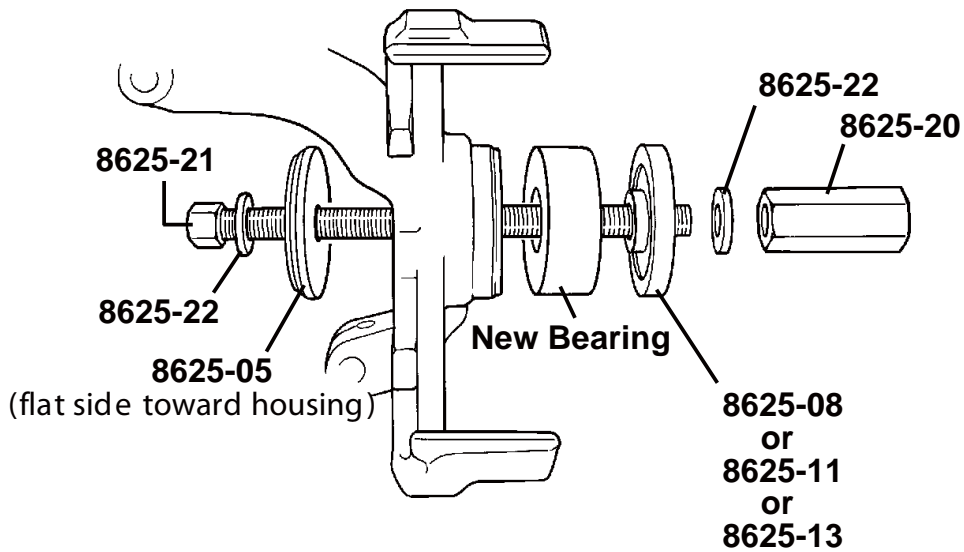

Figure 3

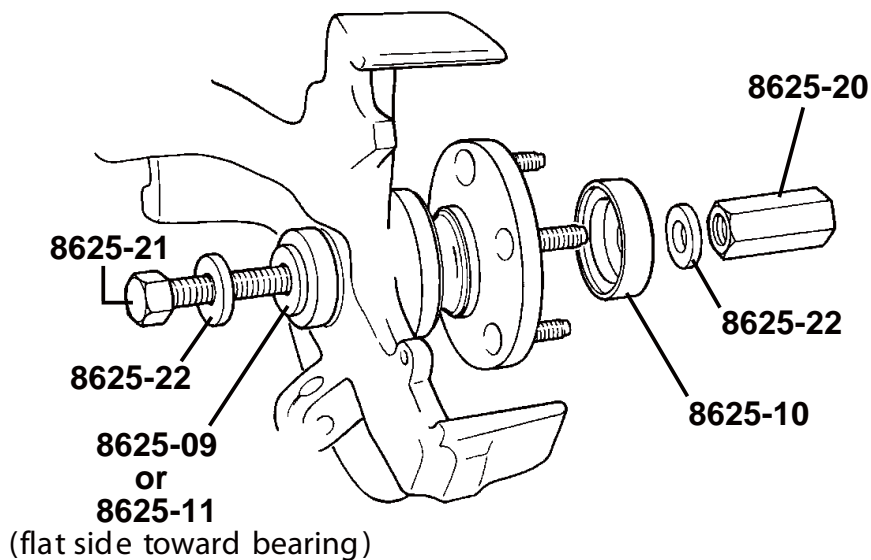

Figure 4



ATD-8625



ITEM#	ORDERING PART#	PART DESCRIPTION
1	PRT8625-01	SLEEVE (4" O.D. x 2.53" LONG)
2	PRT8625-02	SLEEVE (3.625" O.D. x 2.53" LONG)
3	PRT8625-03	SLEEVE (3.25" O.D. x 2.53" LONG)
4	PRT8625-04	SLEEVE (3" O.D. x 2.5" LONG)
5A	PRT8625-05	SMALL SLEEVE PLATE (3.25" O.D. x 2.72" STEP)
5B	PRT8625-06	LARGE SLEEVE PLATE (4" O.D. x 3.2" STEP)
6	PRT8625-07	BUSHING (2.96" O.D.) 955-06
7	PRT8625-08	BUSHING (2.62" O.D.) 955-07
8	PRT8625-09	BUSHING (2.18" O.D.) 955-08
9	PRT8625-10	BUSHING (2.88" O.D.) 955-09
11	PRT8625-11	BUSHING (2.5" O.D.) 955-11
12	PRT8625-12	BUSHING (2.78" O.D.) 955-12
13	PRT8625-13	BUSHING (2.82" O.D.) 955-13
14	PRT8625-14	BUSHING (2.82" O.D.) 955-14
15	PRT8625-15	BUSHING (2.9" O.D.) 955-15
16	PRT8625-16	BUSHING (3.48" O.D.) 955-16
17	PRT8625-17	BUSHING (3.05" O.D.) 955-17
18	PRT8625-18	BUSHING (3.21" O.D.) 955-18
19	PRT8625-19	BUSHING (3.28" O.D.) 955-19
20	PRT8625-20-21	NUT (3" LONG x 0.75"DIA. x 10 T.P.I.)*
21	PRT8625-20-21	SLIDING SCREW (7.5" LONG x 0.75"DIA. x 10 T.P.I.)*
22	PRT8625-22	WASHER (1.5" O.D.)
23	PRT8625-23	BLOW MOLD CARRYING CASE
24	PRT8625-24	SPACER

*PRT8625-20-21 - NUT AND SCREW ARE SOLD AS A MATCHED SET



ATD[®]

WARRANTY

1 YEAR LIMITED WARRANTY

THIS WARRANTY AND CONFIRMED RECEIPT(S) SHOULD BE RETAINED BY THE CUSTOMER AT ALL TIMES

PURCHASED FROM: _____

DATE PURCHASED: _____

INVOICE/RECEIPT NUMBER: _____

Your ATD-8625 is warranted for a period of 12 months from the original purchase date.

For a period of one (1) year from your purchase date, ATD Tools, Inc. will repair or replace (at its option) without charge, your ATD product if it was purchased new and the product has failed due to a defect in material or workmanship which you experienced during normal use of the product. This limited warranty is your exclusive remedy.

To access the benefits of this warranty, contact your supplier, or point of sale directly. You may be advised to return the product under warranty, freight prepaid, to your supplier for warranty determination.

If this ATD product is altered, abused, misused, modified, or undergoes service by an unauthorized technician, your warranty will be void. We are not responsible for damage to ornamental designs you place on this ATD product and such ornamentation should not cover any warnings or instructions or they may void the warranty. This warranty does not cover scratches, superficial dents, and other abrasions to the paint finish that occur under normal use. It also does not cover normal wear items such as but not limited to brushes, batteries, drill bits, drill chucks, pads or blades.

Subject to the law in your state:

- (1) Your sole and exclusive remedy is repair or replacement of the defective product as described above.
- (2) ATD is not liable for any incidental damages, including but not limited to, lost profits and unforeseeable consequences.
- (3) The repair and replacement of this product under the express limited warranty described above is your exclusive remedy and is provided in lieu of all other warranties, express or implied. All other warranties, including implied warranties and warranties of merchantability or fitness for a particular purpose are disclaimed and, if disclaimer is prohibited, these warranties are limited to one year from your date of purchase of this product.

Some states' laws do not allow limited durations on certain implied warranties and some states' laws do not allow limitations on incidental or consequential damages. You should consult the law in your state to determine how your rights may vary.

[Affix receipt or invoice here for safe keeping]