



ATD-8402 90 lbs. Pressure Blaster Owner's Manual



Specifications:

- Nozzle Material: Ceramic
- Max PSI: 125 psi
- Air Inlet: 1/4" NPT
- Minimum Hose Size: 3/8"
- Hose Length: 8 ft.
- Tank Volume: 10 Gallon
- Working Pressure: 60-125 psi
- Overall Dimension: L:13" x W:15" x H:29-1/2"
- Weight: 50 lbs
- Pressurized design offers 30% more abrasive blasting power than siphon units
- Recommended media includes steel grit, glass bead and aluminum oxide
- Deadman control valve for the ultimate in safety and control
- Heavy-duty, all-steel construction blast pot
- Includes 8 ft. hose, shut-off valve, pressure gauge, filling tunnel, water trap and canvas hood
- Includes (4) interchangeable nozzles: 2.0, 2.5, 3.0 & 3.5mm
- 6" wheels and convenient handle for easy mobility
- Requires 6-25 CFM air supply and 60-125 psi working pressure for optimal performance
- Suitable for 90 lbs. of 60 to 100 grit abrasive

ATD abrasive blasting equipment is designed for cleaning and removing rust, scale, paint and dirt. It is the ideal method for stripping, polishing and etching projects. This equipment can be used with abrasive powders and liquids. This model is equipped with the standard use ceramic nozzle.

SAFETY WARNING & CAUTIONS:



WARNING: Airborne dust: This is one of the most serious hazards associated with blasting operations. When evaluating this hazard, it's important to consider the concentration of dust and the size of particles. Larger particles, considered "nuisance" dust, are normally filtered out in the nose and throat. Smaller particles (10 microns or smaller) can bypass the lung's filtering system and penetrate deep into the respiratory system, where they may cause serious damage. Safeguards are needed when smaller particles are present in the working environment.

Metal dust, in addition to the abrasive being used, contributes to the generation of airborne dust. Metals such as lead, cadmium, and manganese, can be extremely toxic when inhaled. Many existing paints have a lead base. Regulations require special handling, trained personnel, and medical monitoring when lead is present. If in doubt, check it out. Don't guess.

Silica sand: This product is a potentially serious health hazard and should NOT be used as an abrasive. If silica containing (quartz) materials are selected for any reason, workers must wear a positive pressure or pressure demand respirator with an assigned protection factor (APF) of either 1000 or 2000. Silica must be contained and disposed of properly. Even if a wet blasting method is selected, silica that is allowed to migrate by either wind or water, will eventually become an airborne contaminant.

Air supply: Air-supplied respirators must be used (1) when working inside of blast cleaning rooms, (2) when using portable units in areas without enclosure, and (3) under any circumstances where the operator is not physically separated from the abrasive material by an exhausted enclosure. If airline respirators and compressors are used, make sure the intake hose is placed in an area that provides clean air. An attendant should be in the area at all times, monitoring breathing air and assuring the blaster's safety.

Additional personal protective equipment: Blasting operations create high noise levels, so hearing protection is a must--for both the operator and nearby workers! Operators should also use heavy canvas or leather gloves, aprons, or leggings when appropriate, as well as safety shoes.

Handling and storing abrasives: Dust is nearly always created at any point where abrasives are transferred, whether by hand or shovel. Therefore, all points of transfer must be properly exhausted and workers who handle abrasives manually should wear particulate filter respirators.

! WARNING: When using pneumatic equipment, basic safety precautions should always be followed to reduce the risk of personal injury and hazards due to over pressurization.

! WARNING: Some dust created by abrasive blasting, grinding, and other construction activities contains chemicals known to the State of California to cause cancer, birth defects, or other reproductive harm. Your risk from exposure varies, depending on how often you do this work. To reduce your exposure to these chemicals: work in a well-ventilated area, and with approved safety equipment, such as dust masks that are specifically designed to filter out microscopic particles.

! WARNING: Always wear eye protection that complies with a recognized standard (CSA or ANSI) when operating or performing maintenance on this tool. User and bystanders.

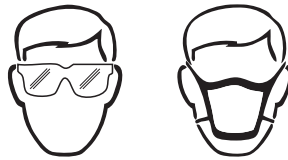

READ ALL INSTRUCTIONS BEFORE USING:

1. Keep work area clean. Cluttered areas invite injuries.
2. Observe work area conditions. Do not use unit in damp, wet or poorly lit locations. Don't expose to rain. Keep work area well lit. Do not use electrically powered air compressors in the presence of flammable gases or liquids.
3. Keep children away. Children must never be allowed in the work area.
4. Do not use inappropriate attachments in an attempt to exceed the unit capacities.
5. Dress properly. Do not wear loose clothing or jewelry as they can be caught in moving parts. Non-skid footwear is recommended. Always wear the hood (included), a dust mask and heavy-duty canvas gloves.
6. Use eye and ear protection. Always wear ANSI approved chemical splash goggles when working with chemicals. Wear an ANSI approved dust mask or respirator when working around metal, wood and chemical dusts and mists.
7. Do not overreach. Keep proper footing and balance at all times. Do not reach over or across running machines.
8. Keep machine clean for better and safer performance. Follow the instructions for lubricating and changing accessories. Inspect compressors cord periodically and if damaged have it repaired by a qualified technician. Inspect all hoses for leak prior to use. The handle must be kept clean, dry and free from oil and grease at all times.
9. Be sure that keys and adjusting wrenches are removed from the unit or work surface before using.

10. Make sure the air pressure adjustment is set at “0 psi” and the shut off valve is in the off position when not in use and before attaching the air compressor.
11. Do not operate the unit when tired or under the influence of alcohol or drugs.
12. Before using check for alignment and binding of moving parts, any broken parts or mounting fixtures and any other conditions that may affect proper operation. Do not use the unit if any switch does not turn on or off properly.
13. When servicing only use parts and accessories intended for use with this unit.
14. Drain water trapped in the air pressure adjuster periodically.
15. Do not allow pressure blaster to be pressurized while unattended or not in use.
16. Make sure all equipment is rated to the appropriate capacity. Make sure that regulator is set no higher than 125 psi.
17. Periodically check the abrasive medium delivery equipment. Valves, hoses and nozzles that carry the abrasive medium after it leaves the pressure tank are subjected to the abrasive blasting action and will wear out more quickly than other components.
18. Release the air pressure in the tank before opening. Open the shut off valve to release pressure. Make sure pressure gauge reads “0 psi” before opening the tank. Do not attempt any repairs to the pressure blaster until the gauge reads “0 psi”.
19. Maintain correct air pressure whenever working. Do not allow pressure to exceed 125 psi. If the safety valve does not release excess air pressure, stop all work and open the shut off valve to release pressure in the tank.





WARNING: The warnings and cautions discussed in this instruction manual cannot cover all possible conditions and situations that may occur. It must be understood by the operator that common sense and caution are factors that cannot be built into this product but must be supplied by the operator.

SAFETY INSTRUCTIONS FOR PRESSURE BLASTER

1. Before opening the tank release the air pressure in the abrasive tank. To do this, turn off the air supply valve (#14) to release pressure in the line. Be sure that the tank pressure gauge (#05) reads zero then open the tank.
2. Maintain correct air pressure. Pressure should not exceed 125 psi. If it does, the safety valve (#06) is supposed to release the excess pressure. If it doesn't release excess pressure, stop all work immediately and disconnect the air compressor to reduce the excess pressure. **Do not** investigate the pressure blaster's pressure problem until the pressure gauge (#05) reads zero.

3. When using pneumatic equipment, basic safety precautions should always be followed to reduce the risk of personal injury and hazards due to over pressurization.
4. Do not operate the unit when tired or under the influence of alcohol or drugs.
5. When servicing only use parts and accessories intended for use with this unit.
6. Do not allow pressure blaster to be pressurized while unattended or not in use.

 **WARNING:** When using tools such as your air compressor, whether powered by electric motor or gasoline engine, basic safety precautions should always be followed to reduce the risk of fire, electric shock and personal injury.

 **WARNING:** The warnings and cautions discussed in this instruction manual cannot cover all possible conditions and situations that may occur. It must be understood by the operator that common sense and caution are factors that cannot be built into this product but must be supplied by the operator.

ASSEMBLY

USE PTFE tape for all threaded air connections

1. Assemble the intake manifold (#08). Attach the pressure gauge (#05) to the top of the intake manifold (#08), and turn the gauge so that it can be seen across the top of the tank. Next, attach the abrasive meter valve (#18) to the bottom of the manifold (#08). Attach the connector (#07A) to the bottom of the abrasive meter valve (#18); attach the nipple connectors (#07) to the manifold (#08). Attach the safety valve (#06) to the manifold (#08) as shown in the diagram.
2. Assemble the water trap filter (#12). Two nipple connectors (#07) are screwed into each side of the filter (#12). Attach the nipple connector (#07) to one side of air supply valve (#14); then attach the male-female connector (#15) to the other side of air supply valve (#14). When ready to operate the pressure blaster, the air hose from compressor will fasten to the male-female connector (#15).
3. Place the tank (#03) on a table with four clips up. Screw the water trap filter(#12) and its parts into the hole at the side of the intake manifold. Then screw the open end of the nipple connector (#07) with intake manifold (#08) and pressure gauge (#05) attached into the threaded hole on the side of the filler pipe on top of the tank. Again, be sure that the manifold and gauge are vertical.
4. Assemble the abrasive outlet valve into the hole at the bottom of the tank. Attach four parts in order: 1pc Nipple Connector (#07); Abrasive Metering Valve (#18); the other nipple connector (#07) and the abrasive outlet pipe (#19).
5. Assemble the abrasive meter valve. Slide two hose clamps (#26) over each end of the abrasive hose (#25). Press one end of the hose over the nipple on the abrasive outlet pipe (#19) and the other end over the intake connector (#27). Both hose ends should be firmly seated on the nipples. Slide the hose clamps along the hose to each nipple and tighten the clamps firmly. They have to resist the force of 65 to 125 psi.

6. Fasten the handlebars (#02) to the tank by using pan screw (#11), washer (#10) and hex nut (#09). Fixing axle brackets (#20) on the tank by using screw (#16). NOTE: Keep the handle curve ends upward.
7. Locate axle (#23) and slide it through the holes at the sides of the axle brackets (#20). Place one wheel (#22) at each end of the axle and fasten them into place with cotter pin (#24) and washer (#21).
8. Insert the fixed foot (#17) onto the fitting on the bottom of the tank near the edge. Use the last cotter pin (#24) to hold the foot on the tank.
9. Before operating, go back over each connection, double checking to ensure that all connections are tight and properly seated.

ABRASIVE SELECTION

The kind of abrasive you choose will greatly influence the amount of time needed to clean a given surface area. Abrasive materials include steel grit, glass bead, aluminum oxide, etc..

If you choose to reuse abrasive, remember it does wear out. The sharp edges become rounder and are less effective. It's at that point you should replace the batch of abrasive that you are using.

LOADING ABRASIVES

1. Check abrasive to be sure it's dry and won't clog the meter valve (#18), abrasive outlet pipe (#19), abrasive hose (#25) or other components.
2. Put on protective clothing.
3. Turn the air supply valve (#14) to the off (horizontal) position.
4. Watch the pressure gauge (#05) and make sure it reads zero.
5. Be sure to get enough abrasive into the tank to do the job at hand. But if this is a big job, only fill the tank 3/4 full and reload as needed to finish the work.
Tips: If the humidity is 90-100%, the water trap (#12) won't be able to trap all of the moisture in a 3/4 filled tank. You'd be better to reduce the amount of abrasive, load more frequently and empty the water trap more often. This will reduce the possibility of clogging the bottom of the tank or the line.
6. With the correct amount of abrasive in the tank, close the gasket (#01), then open the air supply valve (#14).
7. Check for air leaks at the filler cap as you begin to pressurize the tank from the compressor.

MAINTENANCE

1. You should make every effort to protect your air compressor from any damage it may receive from your pressure blaster working. The best option is to keep the compressor in a separate room from the pressure blaster, and use a long hose to provide the PSI needed to do work. A second choice is to keep the compressor up wind from the pressure blasting and the greater the distance between them the better.
2. Some parts of the pressure blaster will wear much more rapidly than others. The parts needing close attention carry the air/abrasive mixture, starting with the abrasive hose (#25) and going through the metal fittings, and finally the abrasive gun.
3. If air leaks develop in any of these parts, stop all work to find out what needs to be repaired or replaced. When it's new, the abrasive hose (#25) has 2 cord ply and the walls are 1/4" thick. As abrasive is blasted through the hose, this wall will become thinner and thinner. One way to inspect the hose and other parts affected by the blasting is to put on the protective clothing. Then pressurize the system and close the nozzle of the abrasive gun. Close your hand loosely around the hose and run it up and down. You will be able feel any leaks. You can also spot places where the wall is getting very thin, as these show up as blisters in the hose. If you find such a blister, get a new hose immediately. If that blister breaks, the abrasive will come out of the side of the hose at 60 psi or more.

AIR SUPPLY REQUIREMENT

Abrasive blasting requires a large volume of air at high pressure. The efficiency of your pressure blaster can be adversely affected by the use of too small of an air supply hose, insufficient air pressure or an oversized nozzle.

HOSE ID	HOSE LENGTH	NOZZLE ID	COMPRESSOR HP	CFM @ 125PSI	ABRASIVE USE PER HOUR
3/8"	50 ft	0.10"	2	6	60 lbs
3/8"	25 ft	0.125"	4	12	100 lbs
1/2"	50 ft	0.150"	7	20	150 lbs
1/2"	25 ft	0.175"	10	25	200 lbs

We recommend that air pressure in the range of 65-125PSI will provide the best results

SPECIFICATIONS:

Model:	ATD-8402
Nozzle Material:	Ceramic
Max PSI:	125 psi
Air Inlet:	1/4" NPT
Minimum Hose Size:	3/8"
Hose Length:	8 feet
Tank Volume:	10 Gallon
Working Pressure:	60-125 psi
Overall Dimension:	L:13" x W:15" x H:29-1/2"
Weight:	50 lbs

TROUBLESHOOTING

PROBLEM	REMEDY
<p>Surging of blast flow? Air pressure too low Too much media</p>	<p>See "Lack of Air Pressure" Adjust media valve</p>
<p>Excessive media consumption? Media valve open too far Air pressure too low</p>	<p>Close slightly Check pressure gauge</p>
<p>Clogging and plugging of blast flow? Debris in media Media size too large Nozzle plugs Wet media</p>	<p>Purge & Screen Use smaller grit size Use large nozzle or Adjust media valve Dry media, drain water from air</p>
<p>Moisture in abrasive media? Wet media Water in air Water in tank</p>	<p>Change or use dry media Drain water from air lines Empty, dry out and refill</p>
<p>Humid weather? Moderate humidity Moderate humidity High humidity</p>	<p>Keep media dry as possible Use drier or moisture separator Avoid that period of use if possible</p>
<p>Overtaxed compressor? Compressor too small Nozzle size too large Too many leaks in air lines Holes in abrasive hose Air filter on compressor plugged</p>	<p>Restrict time used Use smaller size Seal & tighten air lines Replace hose Clean filter</p>
<p>Lack of air pressure? Compressor too small Supply valves not on full position Nozzle size too large Leaks in air lines Holes in abrasive hose Air filter on compressor plugged Urethane gasket worn or dirty</p>	<p>Use smaller nozzle Open valves Use smaller size Seal & tighten air lines Replace hose Clean filter Clean or replace gasket</p>
<p>Lack of abrasive flow? Blaster tank empty Moisture in media Not enough air pressure Abrasive hose kinked Debris in media</p>	<p>Fill tank Dry media Check system Straighten Clean or screen media</p>

REPLACEMENT PARTS

Not all components of this product are replacement items, but are illustrated as a convenient reference for position in the assembly sequence. When ordering parts, give model number, part number and description. Call your distributor for current pricing:

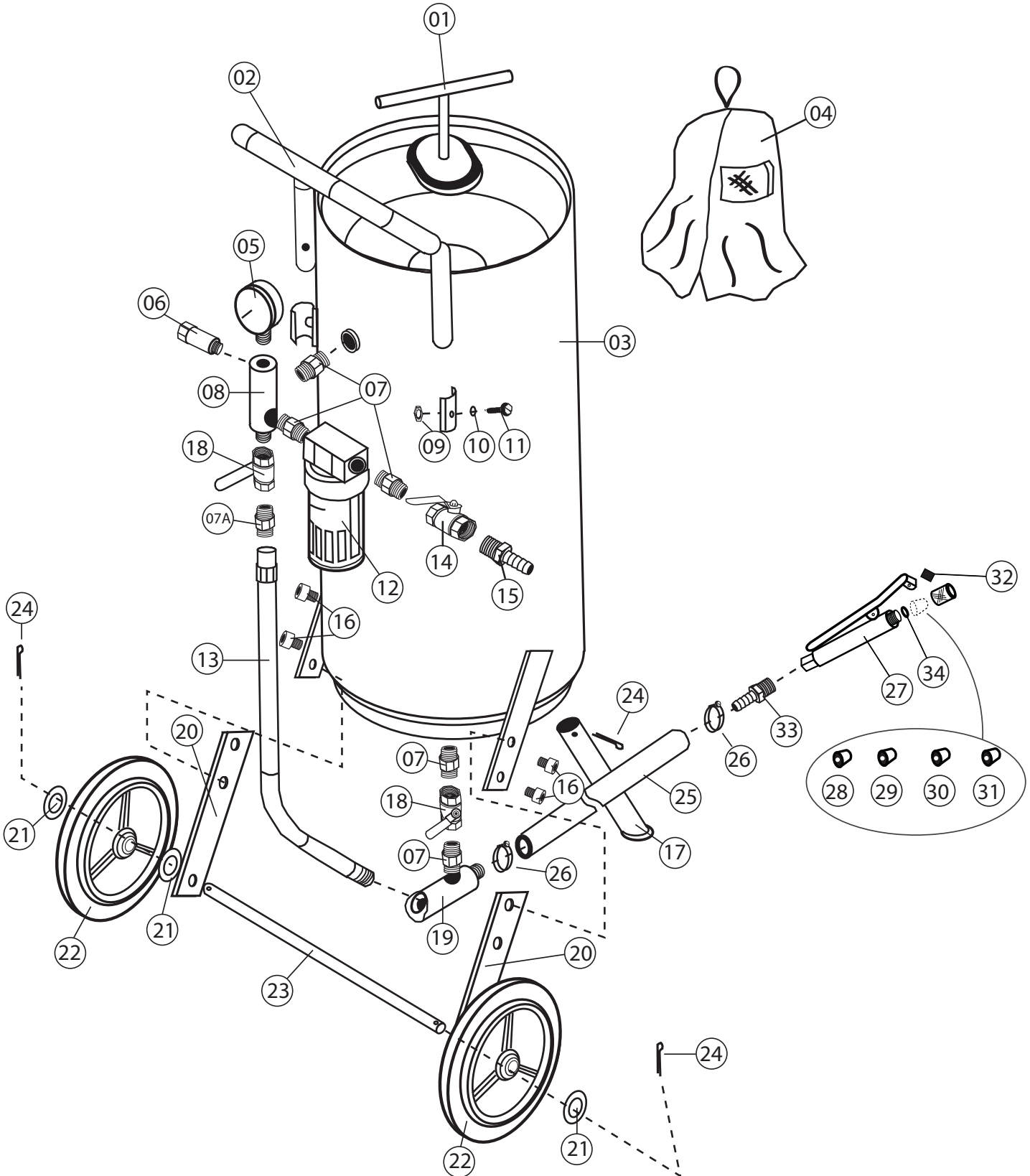

ITEM#	ORDERING PART#	PART DESCRIPTION
01	PRT8402-01	CLOSURE GASKET
02	PRT8402-02	HANDLEBAR
03	PRT8402-03	TANK
04	PRT8401-01	HOOD
05	PRT8402-05	PRESSURE GAUGE
06	PRT8402-06	SAFETY VALVE
07	PRT8402-07	NIPPLE CONNECTOR
07A	PRT8402-07A	CONNECTOR
08	PRT8402-08	INTAKE MANIFOLD
09	PRT8402-09	HEX NUT (M6)
10	PRT8402-10	WASHER
11	PRT8402-11	PAN SCREW
12	PRT8402-12	WATER TRAP FILTER
13	PRT8402-13	AIR HOSE
14	PRT8402-14	3/8" BRASS AIR SUPPLY VALVE
15	PRT8402-15	MALE-FEMALE CONNECTOR
16	PRT8402-16	SCREW (M8X10)
17	PRT8402-17	FOOT
18	PRT8402-18	3/8" ABRASIVE METER VALVE
19	PRT8402-19	ABRASIVE OUTLET PIPE
20	PRT8402-20	AXLE BRACKET
21	PRT8402-21	WASHER
22	PRT8402-22	WHEEL
23	PRT8402-23	AXLE
24	PRT8402-24	COTTER PIN
25	PRT8401-21	ABRASIVE HOSE
26	PRT8402-26	CLAMP
27	PRT8401-24	ABRASIVE GUN
28	PRT8401-28	NOZZLE, 2.0mm
29	PRT8401-29	NOZZLE, 2.5mm
30	PRT8401-30	NOZZLE, 3.0mm
31	PRT8401-31	NOZZLE, 3.5mm
32	PRT8401-32	RUBBER PAD (SHUT OFF BLOCK)
33	PRT8401-23	HOSE ADAPTER
34	PRT8401-33	NOZZLE SEAL



WARRANTY

1 YEAR LIMITED WARRANTY

THIS WARRANTY AND CONFIRMED RECEIPT(S) SHOULD BE RETAINED BY THE CUSTOMER AT ALL TIMES

PURCHASED FROM: _____

DATE PURCHASED: _____

INVOICE/RECEIPT NUMBER: _____

Your ATD-8402 is warranted for a period of 12 months from the original purchase date.

For a period of one (1) year from your purchase date, ATD Tools Inc. will repair or replace (at its option) without charge, your ATD product if it was purchased new and the product has failed due to a defect in material or workmanship which you experienced during normal use of the product. This limited warranty is your exclusive remedy.

To access the benefits of this warranty, contact your supplier, or point of sale directly. You may be advised to return the product under warranty, freight prepaid, to your supplier for warranty determination.

If this ATD product is altered, abused, misused, modified, or undergoes service by an unauthorized technician, your warranty will be void. We are not responsible for damage to ornamental designs you place on this ATD product and such ornamentation should not cover any warnings or instructions or they may void the warranty. This warranty does not cover scratches, superficial dents, and other abrasions to the paint finish that occur under normal use. It also does not cover normal wear items such as but not limited to brushes, batteries, drill bits, drill chucks, pads or blades.

Subject to the law in your state:

- (1) Your sole and exclusive remedy is repair or replacement of the defective product as described above.
- (2) ATD is not liable for any incidental damages, including but not limited to, lost profits and unforeseeable consequences.
- (3) The repair and replacement of this product under the express limited warranty described above is your exclusive remedy and is provided in lieu of all other warranties, express or implied. All other warranties, including implied warranties and warranties of merchantability or fitness for a particular purpose are disclaimed and, if disclaimer is prohibited, these warranties are limited to one year from your date of purchase of this product.

Some states' laws do not allow limited durations on certain implied warranties and some states' laws do not allow limitations on incidental or consequential damages. You should consult the law in your state to determine how your rights may vary.

[Affix receipt or invoice here for safe keeping]