



HEAVY DUTY OIL REEL ASSEMBLY

SYSTEM; Includes: High Volume Oil Control Valve, Ball Stop, Basic Heavy Duty Reel and Medium Pressure Oil Delivery Hose 40 ft x 1/2"

Maximum Operating Pressure: 7500 PSI

Width of Drum: 6.0" (15.2CM);

With: 1/2" NPT(f) Inlet and Outlet Connections

ATD-8199

HEAVY DUTY OIL REEL ASSEMBLY OWNERS MANUAL

RETAIN THIS MANUAL FOR FUTURE REFERENCE TO IMPORTANT WARNINGS AND OPERATING AND MAINTENANCE INSTRUCTIONS.

PROPER USE AND MAINTENANCE OF THIS EQUIPMENT IS THE RESPONSIBILITY OF THE OWNER AND/OR OPERATOR.

DO NOT USE THIS EQUIPMENT UNLESS YOU HAVE CAREFULLY READ AND UNDERSTAND THE INSTRUCTIONS AND WARNINGS IN THIS MANUAL.

! WARNING !

NEVER exceed the stated maximum working pressure of the pump or of the lowest rated component in your system.

NEVER modify any part of this equipment.

NEVER use combustible gas with this equipment.

NEVER attempt repairs while the system is under pressure.

NEVER attempt to disassemble the equipment while the system is under pressure.

ALWAYS tighten fluid connections before using this equipment

ALWAYS read/follow the fluid manufacturer's recommendations regarding fluid compatibility.

ALWAYS read/follow the fluid manufacturer's recommendations regarding the use of protective clothing and equipment.

REGULARLY check all equipment and repair/replace worn or damaged parts immediately.

FAILURE TO HEED THESE WARNINGS INCLUDING OVERPRESSURIZING, ALTERING PARTS, USE OF INCOMPATIBLE FLUIDS, MISUSE, OR USE OF DAMAGED/WORN PARTS MAY RESULT IN EQUIPMENT DAMAGE, PROPERTY DAMAGE, FIRE, EXPLOSION AND/OR SERIOUS PERSONAL INJURY.

SAFETY INSTRUCTIONS

Extreme caution should be used when operating this equipment as it generates very high fluid pressure. Leaks from loose or ruptured components or material from dispensing valve can inject fluid through the skin causing serious bodily injury and possible need for amputation. Always wear protection to prevent material splashing onto skin or into eyes.

IMPORTANT: GET EMERGENCY MEDICAL CARE IMMEDIATELY IF ANY FLUID APPEARS TO PENETRATE THE SKIN! INFORM PHYSICIAN OF EXACTLY WHAT WAS INJECTED. PLEASE DO NOT TREAT THIS INJURY AS A SIMPLE CUT.

! WARNING ! – RELIEF PROCEDURE

DO NOT EVER point the dispensing valve at another person.

DO NOT EVER attempt to stop material from the dispensing valve or a leaking connection with your hand or body.

BEFORE EACH USE, check equipment for proper operation and to insure safety devices are in place and working properly.

NEVER modify this equipment. Modification could cause equipment malfunction and resulting serious bodily injury.

When flushing the pump with solvents, ALWAYS hold a metal part of the dispensing valve firmly to the side of a grounded metal pail and operate pump at the lowest possible fluid pressure to reduce the risk of injury from splashing or static sparking.

WARNING: For Air Operated Equipment: This pump can develop 7500 PSI working pressure at 125 PSI maximum incoming air pressure. Be sure that all system equipment and accessories are rated to withstand the maximum working pressure of this pump. **NEVER** exceed the maximum working pressure of the lowest rated component in the system. **IMPORTANT:** “Whip” hoses for dispensing valve are fluid pressure rated at 4500 PSI. **NEVER** exceed 90 PSI, air pressure to pump when using “whip” hoses.

WARNING: For Air Operated Equipment: Water and even moist air can cause this pump to corrode. To aid in the prevention of this corrosion, **NEVER** leave the pump filled with water or air. After normal flushing, flush the pump once more with mineral spirits or an oil based solvent, relieve pressure and leave the mineral spirits in the pump. It is strongly suggested to put 2-4 fl oz of Lubricating Oil in the Air Motor Inlet every week for Proper Lubrication. **Never use a Synthetic Oil as this will cause irreparable damage to the pump. BE SURE TO CORRECTLY FOLLOW THE PRESSURE RELIEF PROCEDURE.**

PRESSURE RELIEF PROCEDURE

ALWAYS FOLLOW THIS PROCEDURE to reduce the risk of serious bodily injury, including splashing into the eyes. After shutting off the pump; checking/servicing any part of the system; installing/cleaning or changing any part of the system, **ALWAYS** follow this procedure:

1. Disconnect the air supply to the pump.(**IF APPLICABLE**).
2. Aim the dispensing valve away from yourself and others.
3. Aim the dispensing valve into an appropriate container and open until all pressure is relieved.

If you believe that the dispensing valve or hose is completely clogged or that pressure in the pump has not been fully relieved after following the above procedure, **VERY SLOWLY** loosen the hose end coupling to relieve the pressure gradually and then loosen completely. Then proceed to clear the valve or hose.

WARNING: ALWAYS follow the Pressure Relief Procedure after shutting off the pump.

WARNING: ALWAYS follow the Pressure Relief Procedure when checking/servicing any part of the system and when installing, cleaning or changing any part of the system.

INSPECTION INSTRUCTIONS

If you believe that you have overpressurized the equipment, or if your equipment requires adjustments or repair, contact ATD’s service center at 1-800-328-2897 for inspection of the pump.

LUBRICATION: It is recommended to lubricate the Air Motor once a week with 2-4fl oz of Common Lubricating Motor Oil injected into the Airlet port of the Air Motor. This will ensure maximum life of the Air Motor. Never use a Synthetic Oil to Lubricate the Air Motor as this will swell the Buna-N rubber packings and cause irreparable damage.

INSTALLATION

For Air Operated Equipment: It is recommended that you use an **air line filter/regulator/lubricator** to remove harmful dirt and moisture from the compressed air supply and to provide automatic lubrication to the air motor. Blow-dry the lines and hoses with air before connecting them to the system.

ATD WARRANTY & SERVICE CENTER MAY BE CONTACTED AT 1-800-328-2897.

ATD 8199 OIL REEL ASSEMBLY SYSTEM

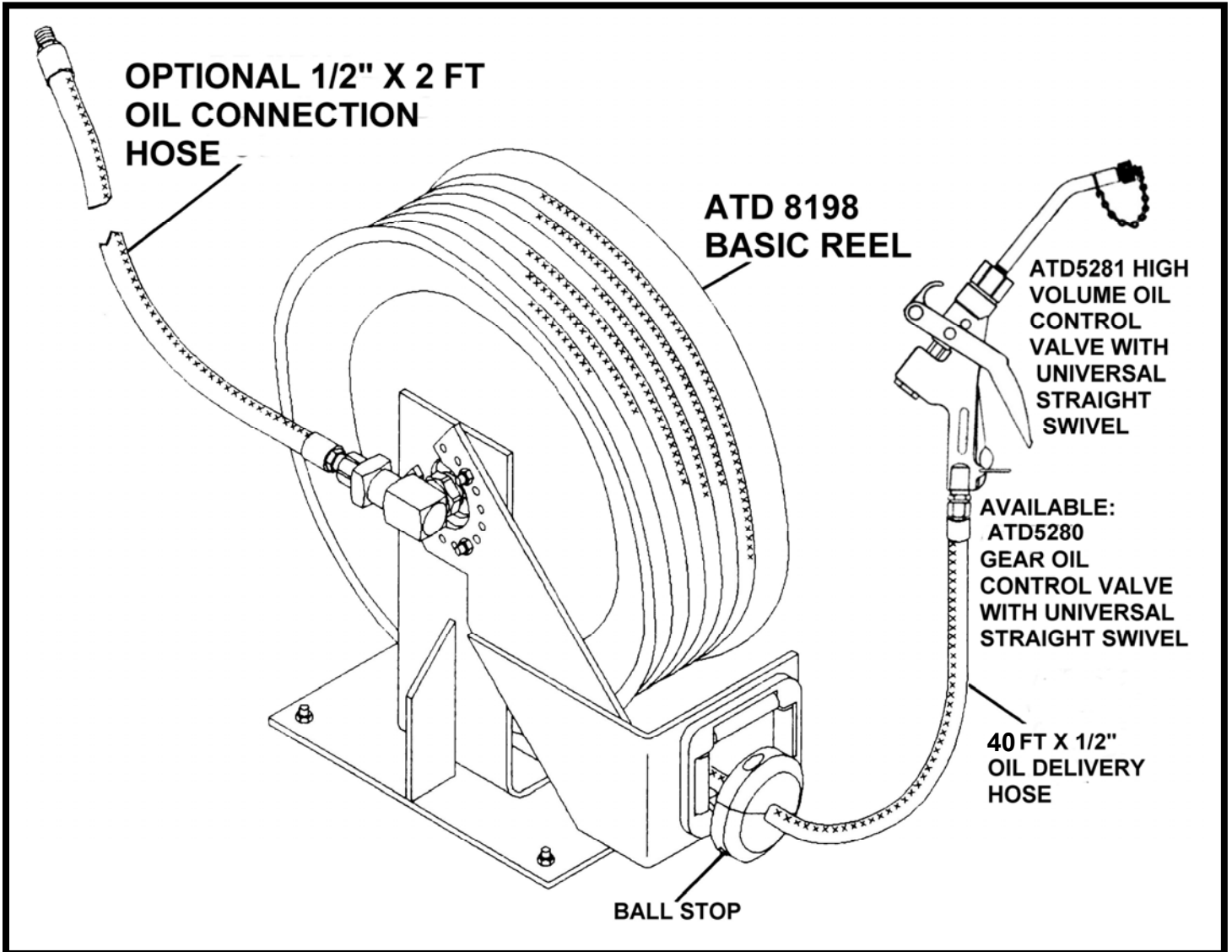

LIST OF PARTS FOR THE ATD-8199 OIL REEL ASSEMBLY

	Optional Medium Pressure Connecting Hose 1/2" x 2FT		Universal Straight Swivel Included in Control Valve
ATD-5281	High Volume Oil Control Valve with Universal Straight Swivel	73480ME	Medium Pressure Oil Delivery Hose 40ft x 1/2"
ATD85517ME	Ball Stop	ATD-8198	Basic Heavy Duty Reel Assembly
ATD-5280	Gear Lube Oil Control Valve with Universal Straight Swivel		

REEL / HOSE TRACK POSITIONS

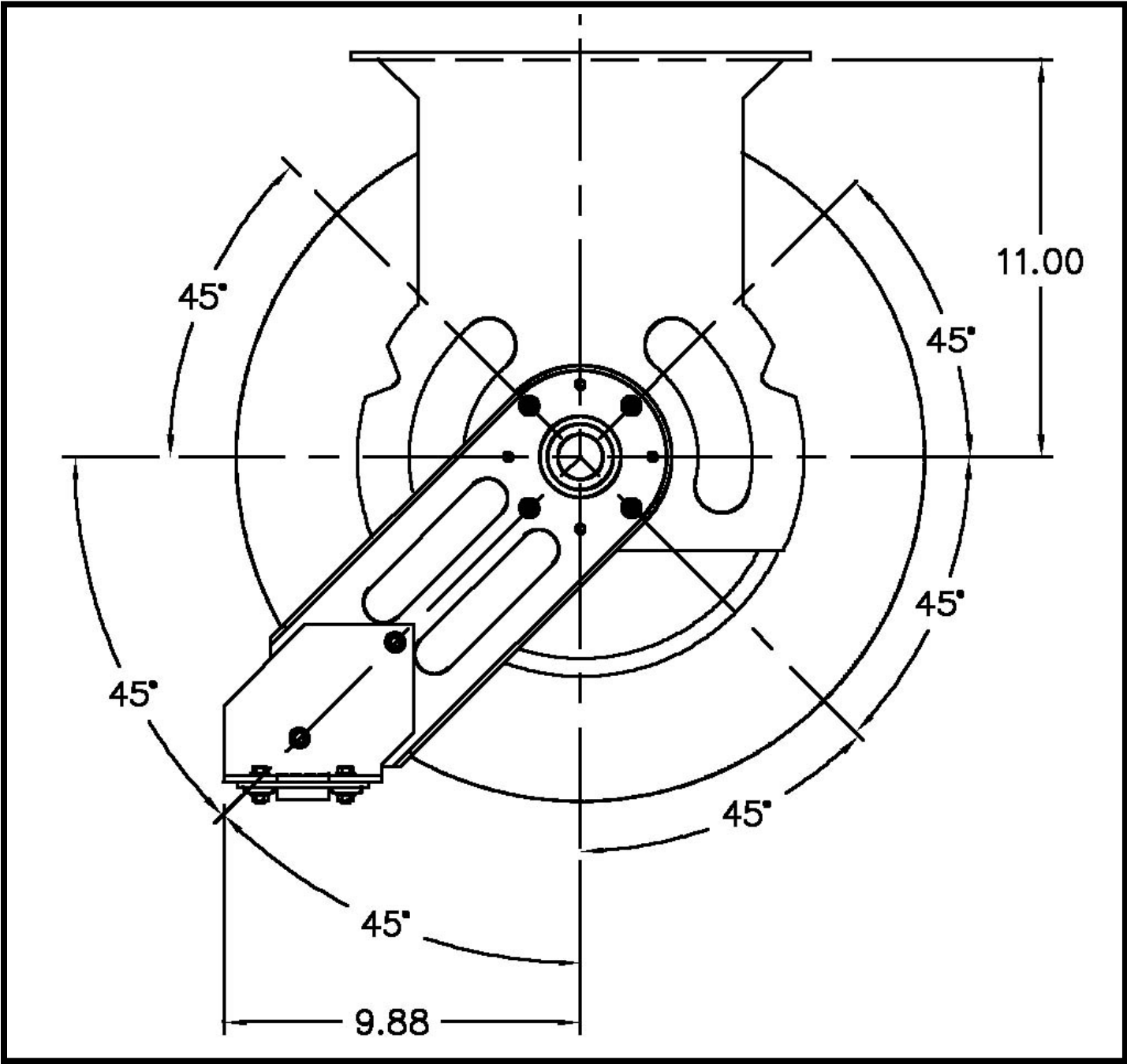

MODEL	POWER SPRING	MAX. HOSE CAPACITY
ATD8198	57082	50' of Type 73 Hose

SECTION YY

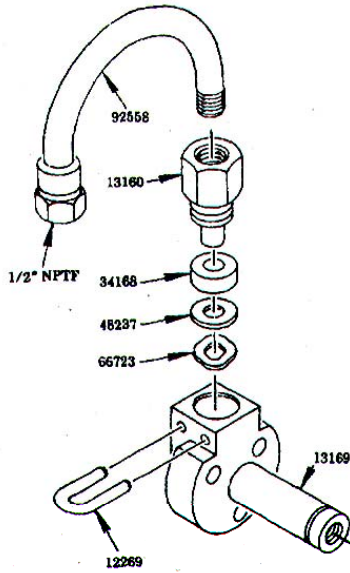

CAUTION

RELIEVE ALL POWER SPRING TENSION BEFORE REMOVING SPRING HOUSING COVER BY RELEASING LATCH AND MANUALLY RESTRAINING UNWIND SPEED OF REEL. SHEAVE ASSEMBLIES SHOULD BE SEPARATED WHEN IN A HORIZONTAL POSITION WITH 45965 DOWN ON A FLAT SURFACE.

NOTE: The power spring is restrained by a steel retainer band. For added safety, the power spring should be wired securely to the retainer band in at least three places before removal from the spring housing.

MODEL ATD8198	
HOSE CLAMP	HOSE TYPE
45816	73
45817	72A & 75
45818	78

Use pipe compound on threads before installing swivel to hose reel.

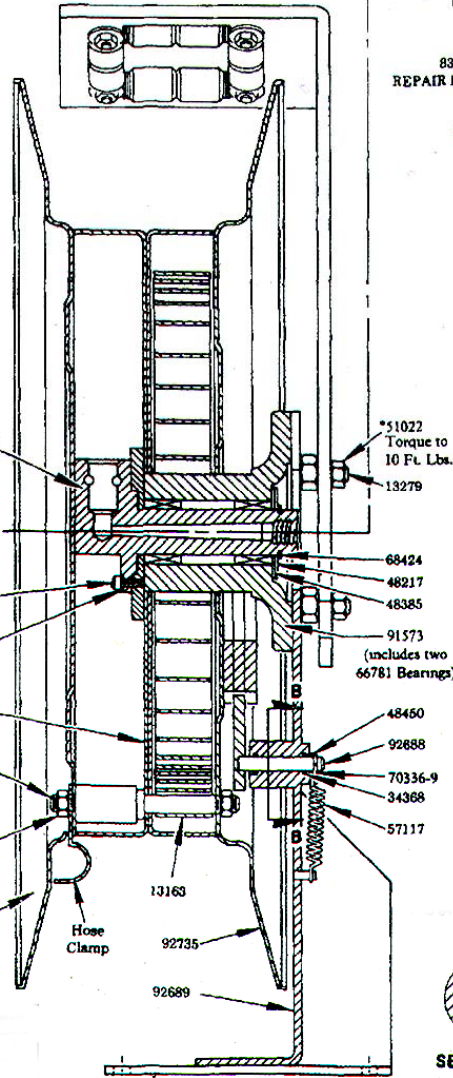

SECTION A-A

82181 SWIVEL ASSEMBLY

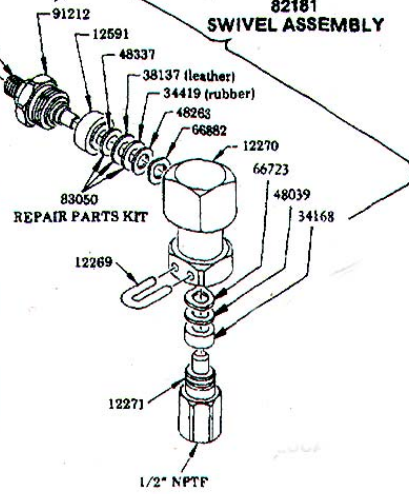

SECTION ZZ

*51022 Torque to 10 Ft. Lbs.

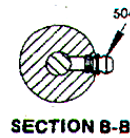

SECTION B-B

MODEL ATD8198 BARE REEL

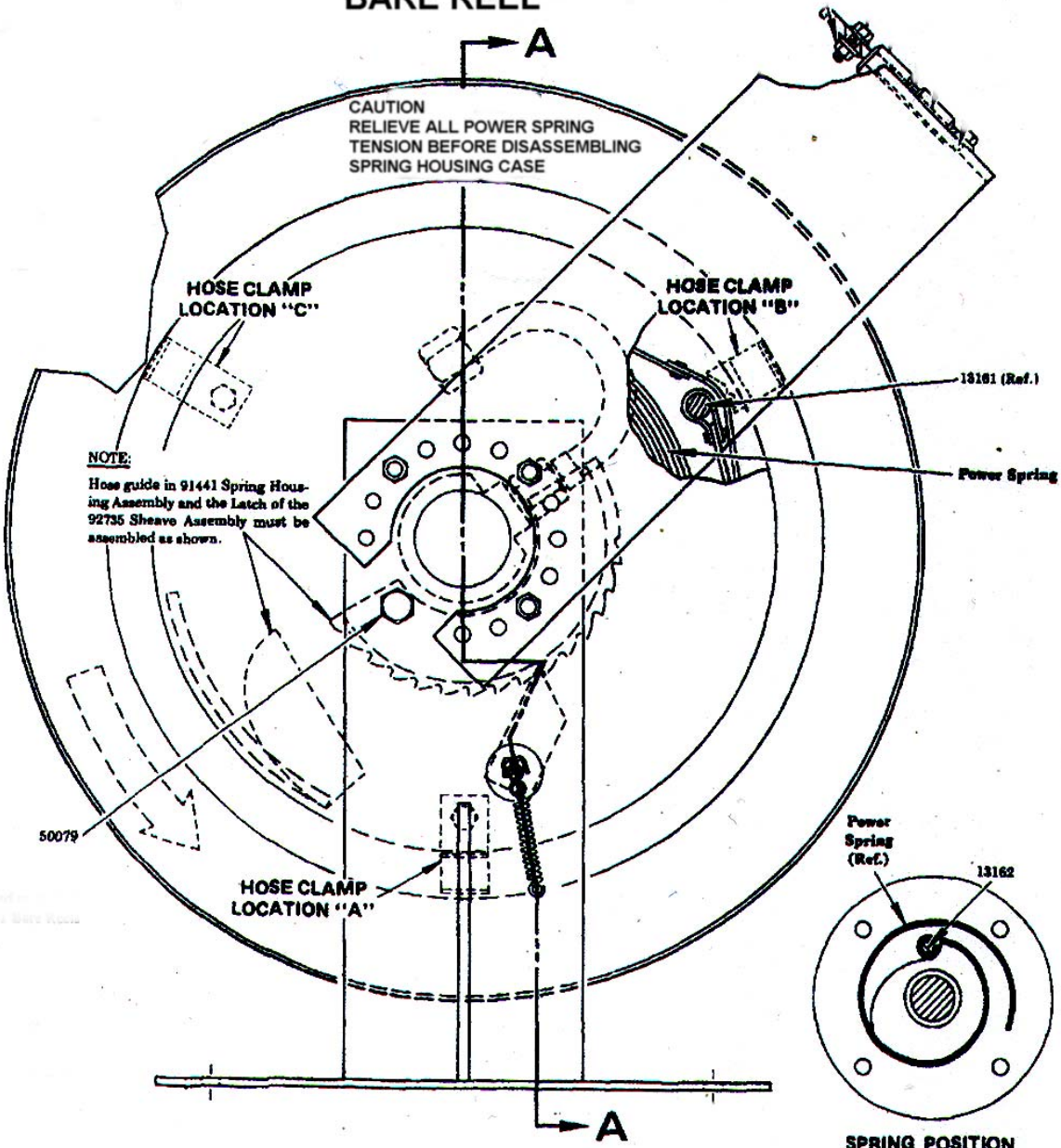

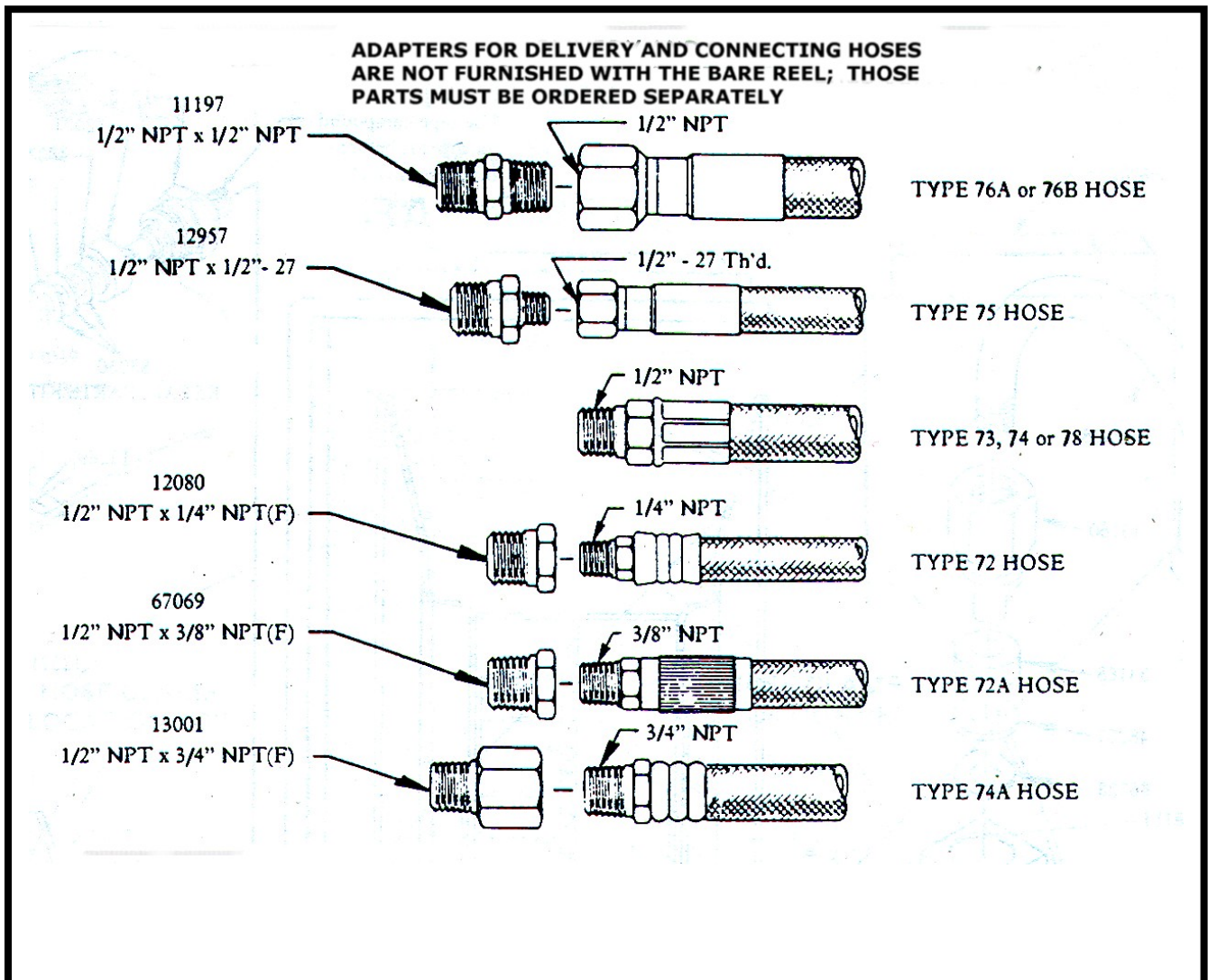
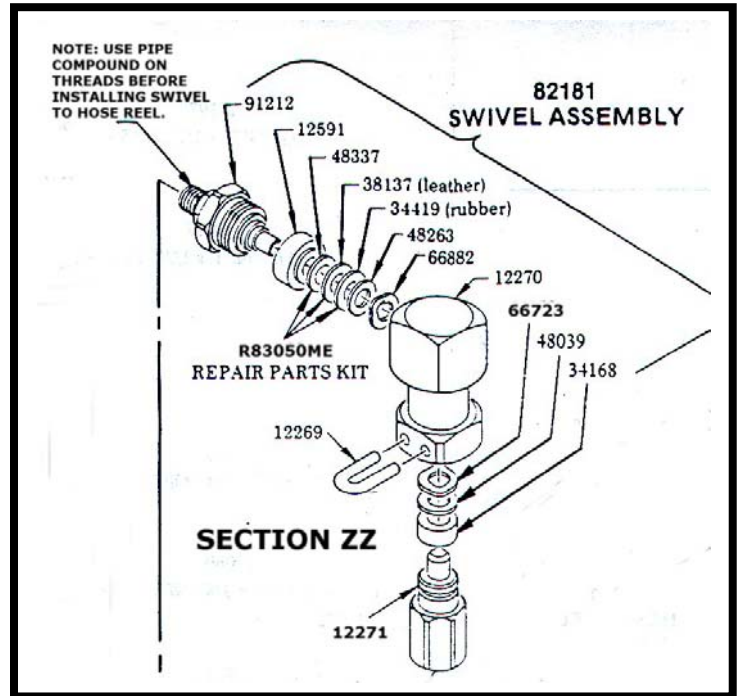
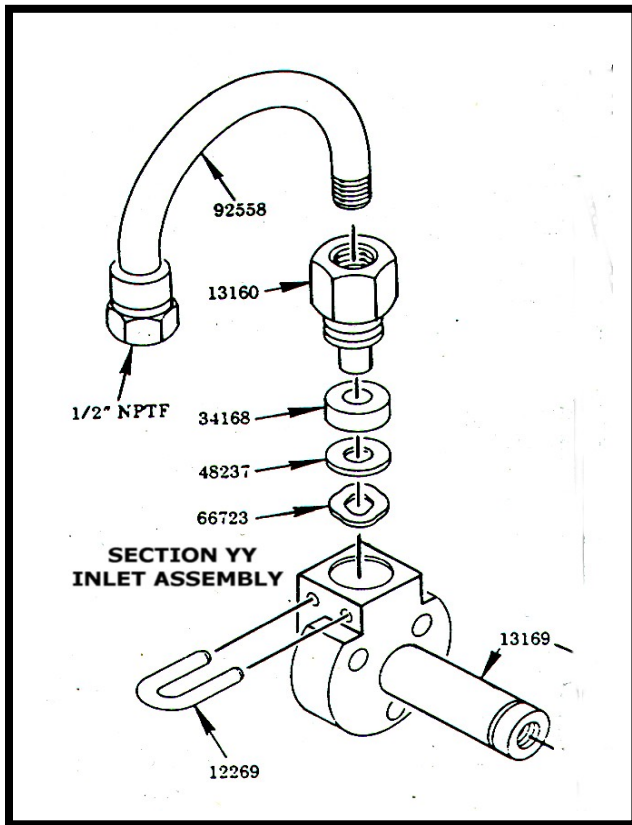

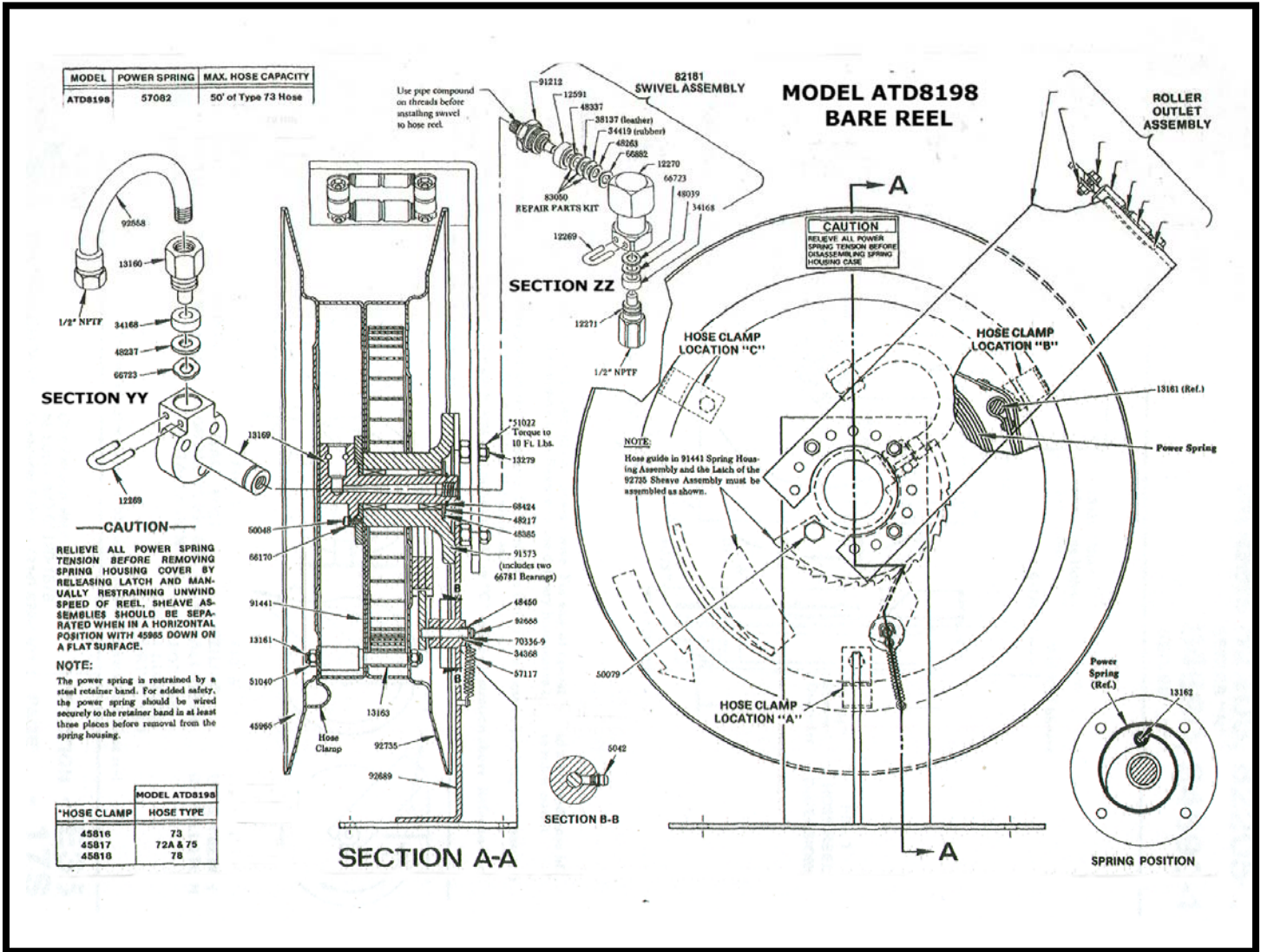

Warning: Use Extreme Caution when working on the Reel Spring. Consider the spring very dangerous.

Caution Note: Relieve all power spring tension before removing spring house cover by releasing latch and manually restraining unwind speed of reel. Sheave assemblies should be separated when in a horizontal position with 45965 down on a flat surface.

Caution Note: The power spring is restrained by a steel retainer band. For added safety the power spring should be wire secured to the retainer band in at least three (3) places before removal from the spring housing.

Note: Use Pipe Compound on Threads before installing swivel on Hose Reel.

ATD-8198 SERVICE PARTS LISTING AND DESCRIPTION

PART	QTY	DESCRIPTION	PART	QTY	DESCRIPTION
5042	1	LUBE FITTING	48385	4	SHIM WASHER
12269	2	KEEPER	48450	1	WASHER
12270	1	SWIVEL BODY	50048	3	SCREW
12271	1	ADAPTER	50079	1	SCREW
12591	1	RETAINER	50757	4	BOLT
13160	1	ADAPTER(12271ME)	51022	3	NUT
13161	3	STUD	51040	6	NUT
13162	1	SPRING PIN	51412	4	NUT
13163	3	SPACER	57117	1	SPRING
13169	1	SHAFT	66170	3	LOCKWASHER
13272	8	ROLLER	66723	2	SPRING WASHER
13273	2	PIN	66781	2	BEARING
13274	2	PIN	66882	1	SPRING WASHER
13275	2	SPACER	68424	1	RETAINING RING
13279	3	STUD	70336-9	1	COTTER PIN
34168	2	PACKING	82181	1	SWIVEL ASSEMBLY
34368	2	O-RING	82860	1	ROLLER OUTLET ASSEMBLY
34419	1	PACKING (RUBBER)THICK	91212	1	SWIVEL STUD
38137	1	PACKING (LEATHER)REPLACED BY 34419ME THICK	91441	1	SPRING HOUSING
45965	1	SHEAVE HALF	91573	1	ARBOR
48039	1	WASHER	92558	1	TUBE & ADAPTER
48217	1	WASHER	92668	1	PAWL
48237	1	WASHER(35039ME)	92689	1	SUPPORT ASSEMBLY
48263	1	WASHER	92735	1	SHEAVE
48337	1	WASHER	360209	1	ROLLER SUPPORT ARM

Repair Kit for Soft Parts: 83050ME; consisting of: 48337ME(Metal Washer), 34419ME(1)(Rubber Packing) or(34419ME-THIN 2PCS RUBBER PACKING); 48263ME(Thin Metal Washer); 66882ME Wave Spring Washer; Note: Item 38137ME (Leather Washer) has been replaced by 34419ME (Rubber Washer)

REF: Threading Hose onto Reels: Please note pictorial below:

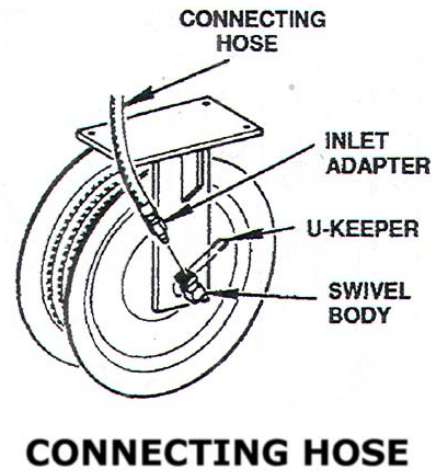
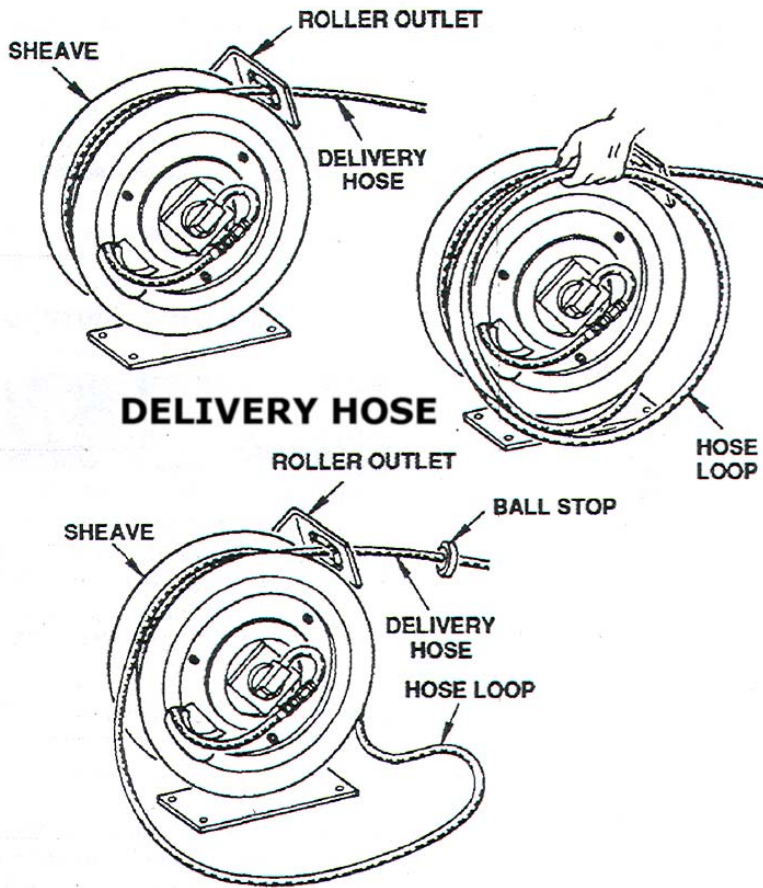

ATD-8198; REEL MOUNTING SUGGESTIONS

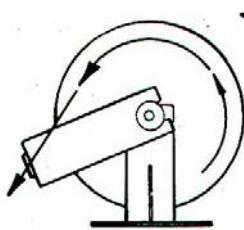

FIG 2
LUBE TRUCK
INSTALLATION
CONTRACTOR

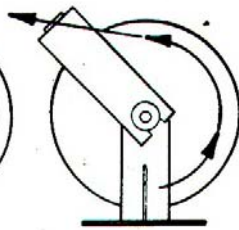

FIG 3
FLOOR
INSTALLATION

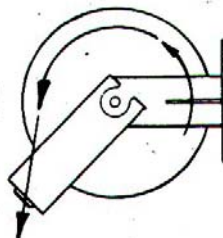

FIG 4
WALL, POST
OR ABOVE BENCH
INSTALLATION

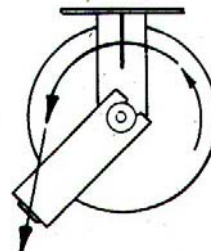

FIG 5
CEILING
INSTALLATION

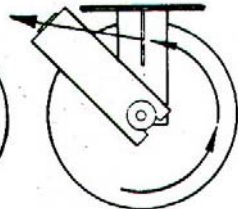

FIG 6
UNDER BENCH
INSTALLATION

ATD8199

DESCRIPTION: Heavy Duty High Pressure Oil Reel Assembly
Oil Reel Assembly (Heavy Duty Reel; ATD8198(specs stated below)); Includes: 40ft(12.2mtrs) x 1/2" Oil Delivery Hose; Connecting Swivel, Hose Stop, ATD5281 High Volume Oil Control Valve; Reel Connections: 1/2"NPT(f).

Heavy Duty Basic Reel: Includes Swivel on the Reel; No Delivery Hose; No Connecting Hose; No Control Valve; Hose Connections: 1/2"NPT(f); **Additional Information and Specifications:** Heavy Duty Reel for Grease, Oil, Antifreeze, Water, Air with steel rollers and Heavy Steel Mounting Base.

Specifications:

Type: High Pressure: 7500 PSI

Inlet / Outlet: 1/2"(1.27CM)

Sheath Width Outside to Outside: 6-1/2" (approx)16.5CM

Sheath Width Indiside to Inside: 6.0" (approx)(15.2CM)

Sheath Depth: 4.0"(10.2CM)

Diameter of Sheath: 20"(50.8CM)

Base: 12-3/4"(32.4CM) x 6"(15.24CM)

Base Thickness: 1/4" Plate Steel with 4 3/8"(11.1CM) DIA mounting holes for easy mounting of the base to any support column, rafter or floor

Length of Arm: 15"(38.1CM)

Solid Metal Rollers with a diameter of: 2-1/8"(5.4CM) x 2-1/8"(5.4CM)

Applications: Grease, Oil, ATF, Antifreeze, Water, Air

Carries Hose: SAE 100R2 75 50 FT(15.2mtrs)

SAE 100R2 76A 50 FT(15.2mtrs)

SAE 100R2 76B 50 FT(15.2mtrs)

SAE100R3 73 50 FT(15.2mtrs)

SAE100R1 78 50 FT(15.2mtrs)

SAE 100R3 74A 40 FT((12.2mtrs)

SAE100R6 72 50 FT(15.2mtrs)

BOX Weight: 80LBS(36.3KG)

BOX Dimensions: 24" x 24" x 16" (61cm x 61cm x 40.6cm)

Application: Installed Lube in Garage, Maintenance Facility, Quick Lube, Industrial, Factory

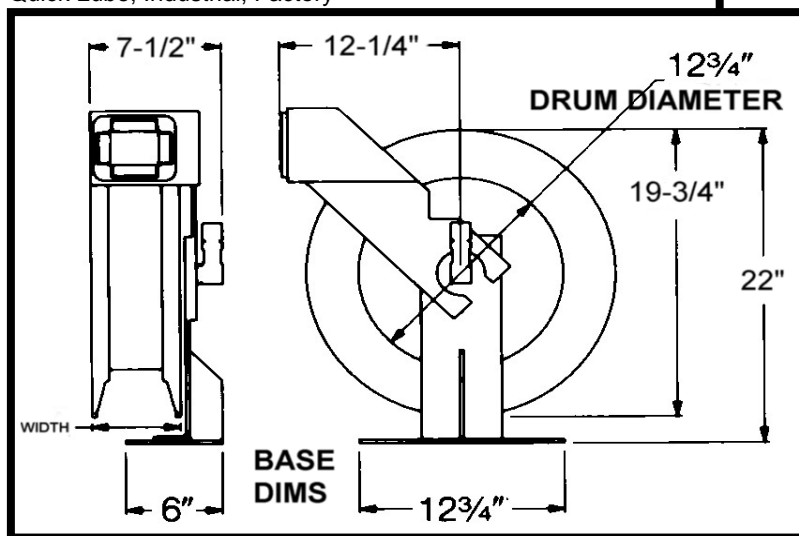

ATD Tools Inc.
DISTRIBUTOR

ATD