

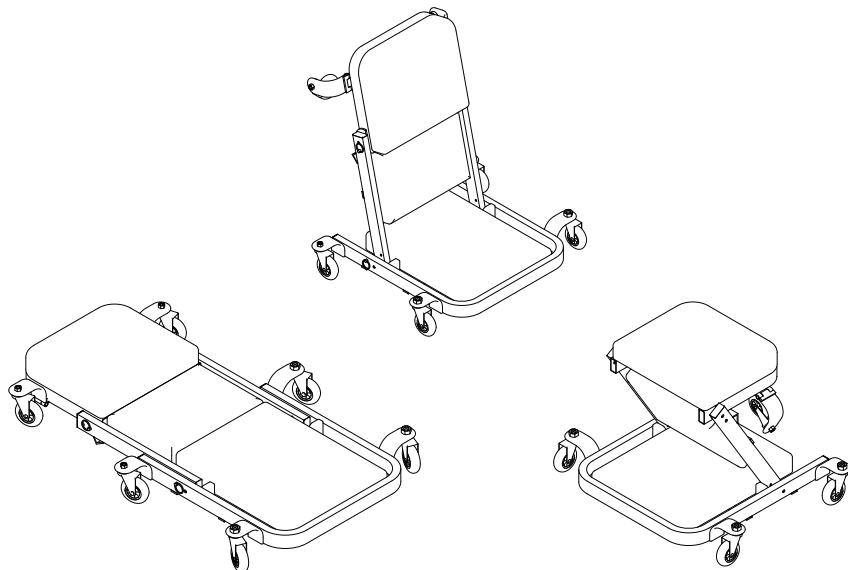

ATD-81049 Low Profile Z Creeper Owner's Manual



Features:

- Comfortable fully upholstered pad
- (6) oil and chemical resistant 3" wheels
- Powder coated steel frame
- Quickly and easily converts from low profile creeper to Z-Creeper seat to L-Seat
- Perfect for the mechanic, paint & body or detail shop

Specifications:

- Weight Capacity: 450 lbs.
- 40" L X 26" W X 4-3/4" H
- Weight: 25.8 lbs.

U.S. Patent No. D639,638S and 6,969,077
Other U.S. Patent Pending



The safety symbol is used to alert you to potential personal injury hazards. Obey all safety messages that follow this symbol to avoid possible injury or property damage.

Read this manual and follow all Safety Rules and Operating Instructions before using this product.

Made in China to ATD Tools, Inc. Specifications
Visit us at www.atdtools.com

ATD81049_rev_0320

SAFETY AND GENERAL INFORMATION

For your safety, read, understand, and follow the information provided with and on this folding creeper. The owner and operator shall have an understanding of this product and safe operating procedures before attempting to use. The owner and operator shall be aware that use of this product may require special skills and knowledge. Instructions and safety information shall be conveyed in the operator's native language before use of this product is authorized. Make certain that the operator thoroughly understands the inherent dangers associated with the use and misuse of the product. If any doubt exists as to the safe and proper use of this product, remove from service immediately.

Inspect before each use. Do not use if there are broken, bent, cracked or damaged parts (including labels). Any folding creeper that appears damaged in any way, or operates abnormally shall be removed from service immediately. If the folding creeper has been subjected to a shock load (load dropped suddenly or unexpectedly upon it), immediately discontinue use until it has been inspected by an ATD authorized service center. It is recommended that an annual inspection be done by qualified personnel. Labels and Operator's Manuals are available from manufacturer.

PRODUCT DESCRIPTION

This device is designed to be folded in a 'Z' shape or 'L' shape for use as a mechanic's seat or unfolded for use as a mechanic's creeper. It is intended to be used to support and move rated capacity loads (a single person, tools and equipment weighing no more than 450 lbs.) for the purpose of performing automotive maintenance or service. Use on smooth, level surfaces only. This device is not intended, designed or engineered to be used for any other purpose.

⚠ WARNING: Do not use this device for any purpose other than that for which it is expressly intended.

⚠ WARNING

To avoid personal injury and property damage:

- Read, understand, and follow all printed materials provided with and on this product before use.
- Do not exceed rated capacity of 450 lbs. Rated capacity consists of: 1 person, tools, equipment totaling 450 lbs.
- Use on smooth, level, seamless surfaces only!
- Sit down gently! Avoid shock loads caused by jumping or falling onto seat.
- Do not stand on this product.
- Keep out of the reach of children! This device is not appropriate for children's use.

SPECIFICATIONS

| Model | Rated Capacity | Creeper Size | Cushion Size | Weight |
|-----------|----------------|--------------------|--------------|-----------|
| ATD-81049 | 450 lbs. | 40" x 26" x 4-3/4" | 39" x 13" | 25.8 lbs. |

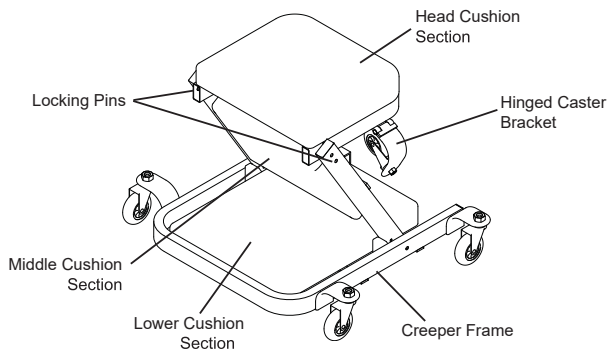

PREPARATION

Before assembling your Folding Creeper, make sure all parts are present. Compare parts with package contents list and illustrations. If any part is missing or damaged, do not attempt to assemble, install or operate the product. Contact your distributor for replacement parts. Packaging contents: (1) creeper body with cushions, (6) casters (6) caster lock nuts.

ASSEMBLY

1. Carefully unfold the creeper until flat. Engage spring loaded Locking Pins.

⚠ CAUTION: *Folding components can present pinch and crush hazards during normal use of this product. Exercise caution when performing adjustments and while assembling and using this equipment.*

2. Attach casters to creeper frame caster brackets using 17mm nuts.

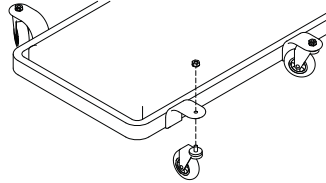

OPERATION

1. Locate and unlock spring loaded locking pin for middle section by pulling out until disengaged. Then rotate head frame and middle frame upward as shown in Fig. 1 until the locking pin can engage hole in creeper seat locking plate (ensure lock pin is fully engaged). This is the low seat configuration.

2. Disengage lock pin for middle frame and rotate further forward. Engage locking pin. Disengage lock pin for head frame section and rotate backwards as shown in Fig. 2. Adjust hinged caster brackets as required. This is the high seat configuration.

⚠ CAUTION: *Ensure all lock pins are properly engaged before using creeper.*

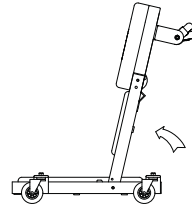

Figure 1 - Low seat configuration

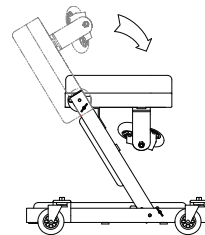

Figure 2 - High-seat configuration

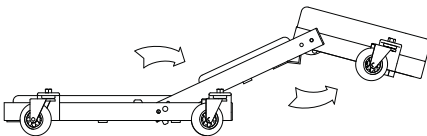

Figure 3 - Creeper configuration

3. Adjust hinged caster brackets so wheels will contact ground properly. Unlock spring loaded lock pins, then reverse steps 1 and 2, as shown in Fig. 3, to convert creeper seat into creeper.

MAINTENANCE

Wipe clean as needed. Use mild upholstery cleaner (not caustic) to clean cushions.

⚠ CAUTION: *Do not add lubricant to casters.*

REPLACEMENT PARTS

Not all components of the creeper can be replaced. Please contact your distributor for parts. When ordering parts, please provide the model number, part number, and part description. Contact your distributor for current pricing.

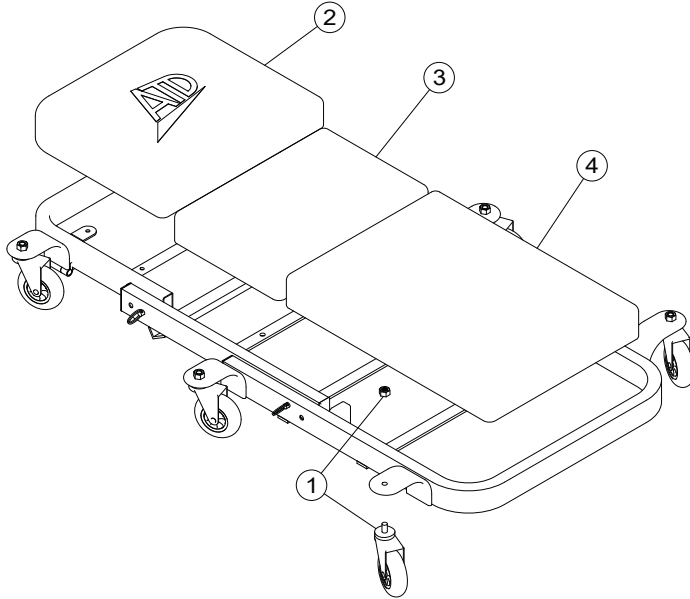

REPLACEMENT PARTS LIST

| Item | Part No. | Description | Qty |
|------|-------------|-----------------|-----|
| 1 | 91400-1 | Caster Assembly | 6 |
| 2 | 91452-2-ATD | Head Cushion | 1 |
| 3 | 91452-3 | Middle Cushion | 1 |
| 4 | 91452-4 | Lower Cushion | 1 |



WARRANTY

1 YEAR LIMITED WARRANTY

THIS WARRANTY AND CONFIRMED RECEIPT(S) SHOULD BE RETAINED BY THE CUSTOMER AT ALL TIMES

PURCHASED FROM: _____

DATE PURCHASED: _____

INVOICE/RECEIPT NUMBER: _____

Your ATD-81049 is warranted for a period of 12 months from the original purchase date.

For a period of one (1) year from your purchase date, ATD Tools Inc. will repair or replace (at its option) without charge, your ATD product if it was purchased new and the product has failed due to a defect in material or workmanship which you experienced during normal use of the product. This limited warranty is your exclusive remedy.

To access the benefits of this warranty, contact your supplier, or point of sale directly. You may be advised to return the product under warranty, freight prepaid, to your supplier for warranty determination.

If this ATD product is altered, abused, misused, modified, or undergoes service by an unauthorized technician, your warranty will be void. We are not responsible for damage to ornamental designs you place on this ATD product and such ornamentation should not cover any warnings or instructions or they may void the warranty. This warranty does not cover scratches, superficial dents, and other abrasions to the paint finish that occur under normal use. It also does not cover normal wear items such as but not limited to brushes, batteries, drill bits, drill chucks, pads or blades.

Subject to the law in your state:

- (1) Your sole and exclusive remedy is repair or replacement of the defective product as described above.
- (2) ATD is not liable for any incidental damages, including but not limited to, lost profits and unforeseeable consequences.
- (3) The repair and replacement of this product under the express limited warranty described above is your exclusive remedy and is provided in lieu of all other warranties, express or implied. All other warranties, including implied warranties and warranties of merchantability or fitness for a particular purpose are disclaimed and, if disclaimer is prohibited, these warranties are limited to one year from your date of purchase of this product.

Some states' laws do not allow limited durations on certain implied warranties and some states' laws do not allow limitations on incidental or consequential damages. You should consult the law in your state to determine how your rights may vary.

[Affix receipt or invoice here for safe keeping]