



## ATD-81047 Heavy Duty Tool Box Creeper Seat Owner's Manual



**Capacity: 450 lbs**

### Features:

- Padded seat cushion for comfort
- Front and back tool trays
- Welded steel frame
- 3" polyurethane, oil-resistant, full-bearing casters for smooth movement



*The safety alert symbol is used to alert you to potential personal injury hazards. Obey all safety messages that follow this symbol to avoid possible injury or property damage.*

**Read this manual and follow all Safety Rules and Operating Instructions before using this product.**

**Save these instructions.** For your safety, read, understand, and follow the information provided with and on this product before using. The owner and/or operator shall have an understanding of safe use / operating procedures before attempting to use. The owner and/or operator shall be aware that the use of this product may require special skills and knowledge. Instructions and safety information shall be conveyed in the operator's native language before use of this device is authorized. If any doubt exists as to the safe and proper use of this product as outlined in this factory authorized manual, remove from service immediately.

**Inspect before each use.** Do not use if broken, bent, cracked, or damaged parts (including labels) are noted. Any Tool Box Seat that appears damaged in any way, operates abnormally or is missing parts, shall be removed from service immediately and the manufacturer notified. If you suspect that this product was subjected to a shock load (a load dropped suddenly, unexpectedly upon it), immediately discontinue use until it has been checked by a factory authorized service center (contact distributor or manufacturer for list of Authorized Service Centers). It is recommended that an annual inspection be done by qualified personnel. Labels and owner's manuals are available from manufacturer (see Replacement Parts, page 4).

**PRODUCT DESCRIPTION**

This device is designed to support and transport, along a smooth and level surface, one person, tools, and equipment weighing **\*450 lbs. or less** for the purpose of performing automotive maintenance or service. This device **is not** intended, designed or engineered to be used for any other purpose.

Rated Capacity: One (1) person weighing **450** lbs. or less- \* includes person, tools, equipment, personal items

 **Do not use this device for any purpose other than that for which it is expressly intended.**

**SPECIFICATIONS**

Model	Rated Capacity	Overall Toolbox Dimension Length, Width, Height	Tool Drawer Inner Dimension Length, Width, Height
ATD-81047	450 lbs	18-1/4" x 14-3/4" x 18-3/4"	12-3/4" x 7-3/4" x 2-3/8"

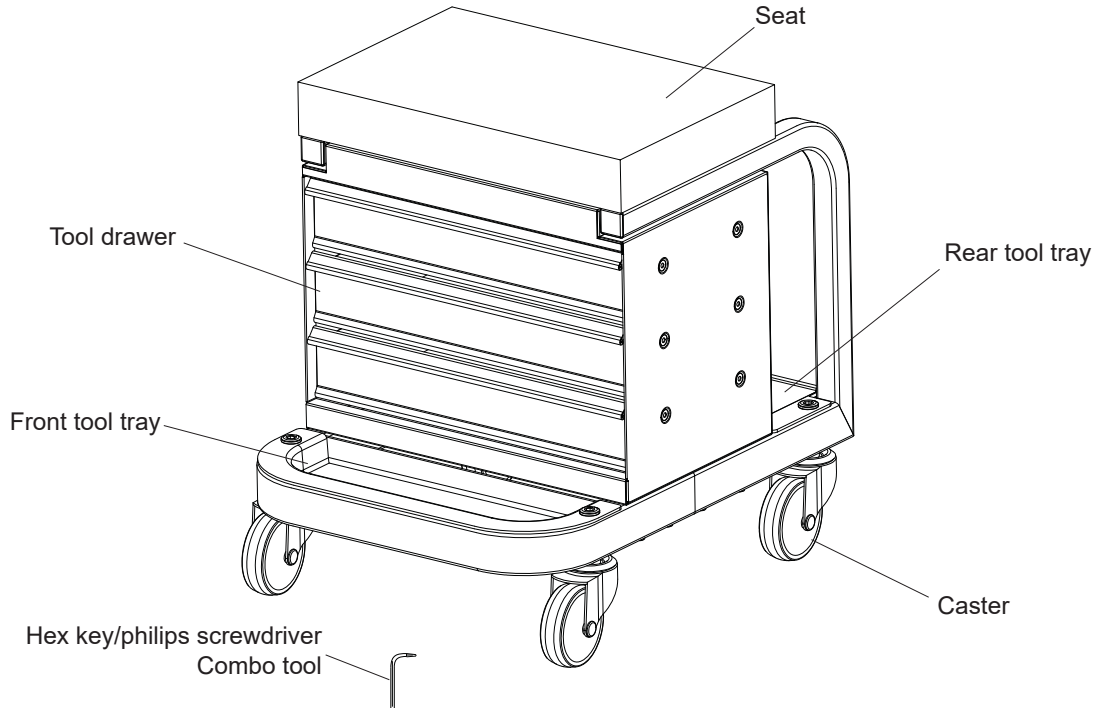

Figure 1 - Model ATD-81047 Nomenclature

# !WARNING

## To avoid personal injury and property damage:

- **Read, understand, and follow** all printed materials provided with and on this product before use.
- **Do not** exceed rated capacity of **450 lbs.** Rated capacity consists of: **1** person, tools, equipment totaling **450 lbs.**
- Use on smooth, level, seamless surfaces only!
- Sit down gently! Avoid shock loads caused by jumping or falling onto seat.
- Do not stand on this product.
- Keep out of the reach of children! This device is not appropriate for children's use.

Before beginning assembly of product, make sure all parts are present. Compare parts with package contents list and Figure 2 illustration. If any part is missing or damaged, do not attempt to assemble, install or operate the product. Contact customer service for replacement parts.

## Package Contents List

Item	Description	Qty
A	Tool Box Sub-Assembly	1
B	Caster Fasteners	4
C	Rear Tool Tray	1
D	Flat Washer	4
E	Swivel Caster	4
F	Front Frame Section	1
G	#2 Philips Screw	2
H	Front Tool Tray	1
J	Hexhead-Philips Screwdriver Tool	1
K	Spring Washer	4
L	Phillips Screw 55L	2

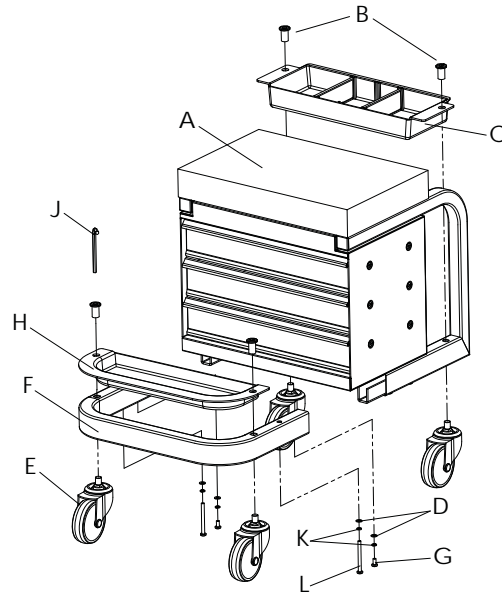

Figure 2- Assembly

## ASSEMBLY INSTRUCTIONS (ref. Figure 2)

A Hex Key-Philips Screwdriver Combo Tool (J) is provided and should be the only tool needed to complete assembly.

1. Join frame sections by inserting front frame section (F) into channel sections of tool box subassembly (A). Line up screw holes and thread screws (G) fitted with washers (D) into corresponding holes in channel sections. Do not tighten screws yet.
2. Assemble a caster (E) and a tool tray (C or H) simultaneously. Position a caster stud into lower frame hole as seen in Figure 2. Place tool tray into position by aligning the lower frame thru-hole with corresponding hole in tool tray. Insert caster fastener into the swivel caster stud.
3. Repeat assembly above for remaining casters and tool tray. Once tool trays have been successfully installed, hand tighten all assemblies with provided Combo Tool.
4. Ensure casters swivel and roll easily. Check Tool Box drawers for ease of movement.

## OPERATING INSTRUCTIONS (Refer to Fig. 1, 2)

Understand and follow all warning information.

1. Load tool drawers carefully. Pull drawer open to remove, push to close.
2. After using a tool, wipe clean and dry before returning it to the tool box.
3. The toolbox seat is NOT suitable for storing flammable, combustible, or corrosive materials.



**Keep hands away from pinch and laceration hazards points that are created during use! Be alert and sober when using this product! Sit centrally on seat pad ONLY. NEVER sit on edge!**

### MAINTENANCE

Little maintenance is required of this device. Wipe clean as needed. Use mild upholstery cleaner (not caustic) to clean seat as needed.



**DO NOT lubricate casters!**

### REPLACEMENT PARTS

Not all components of this product are replacement items, but are illustrated as a convenient reference for position in the assembly sequence. When ordering parts, give model number, part number and description. Call your distributor for current pricing:

#### Replacement Parts List

Item	Description	Qty
92450-A-ATD	Seat Cushion	1
92450-B	Caster Fasteners	4
92450-C	Rear Tool Tray	1
92450-D	Flat Washer	2
92450-E	Swivel Caster	4
92450-G	#2 Philips Screw	2
92450-H	Front Tool Tray	1

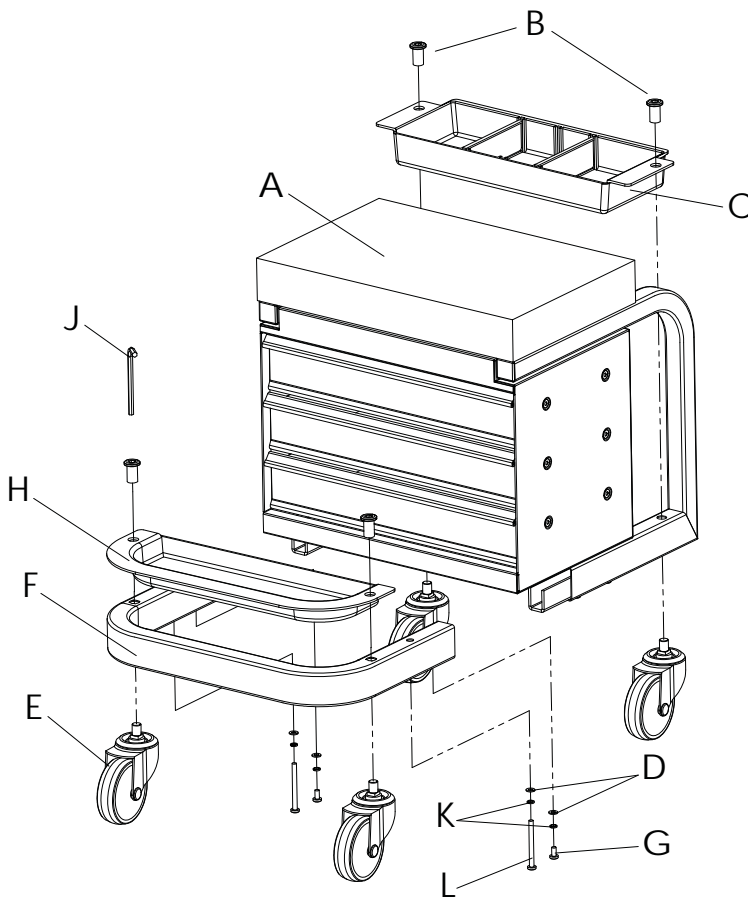



**WARRANTY**  
**1 YEAR LIMITED WARRANTY**

**THIS WARRANTY AND CONFIRMED RECEIPT(S) SHOULD BE RETAINED BY THE CUSTOMER AT ALL TIMES**

PURCHASED FROM: \_\_\_\_\_

DATE PURCHASED: \_\_\_\_\_

INVOICE/RECEIPT NUMBER: \_\_\_\_\_

Your ATD-81047 is warranted for a period of 12 months from the original purchase date.

For a period of one (1) year from your purchase date, ATD Tools Inc. will repair or replace (at its option) without charge, your ATD product if it was purchased new and the product has failed due to a defect in material or workmanship which you experienced during normal use of the product. This limited warranty is your exclusive remedy.

To access the benefits of this warranty, contact your supplier, or point of sale directly. You may be advised to return the product under warranty, freight prepaid, to your supplier for warranty determination.

If this ATD product is altered, abused, misused, modified, or undergoes service by an unauthorized technician, your warranty will be void. We are not responsible for damage to ornamental designs you place on this ATD product and such ornamentation should not cover any warnings or instructions or they may void the warranty. This warranty does not cover scratches, superficial dents, and other abrasions to the paint finish that occur under normal use. It also does not cover normal wear items such as but not limited to brushes, batteries, drill bits, drill chucks, pads or blades.

Subject to the law in your state:

- (1) Your sole and exclusive remedy is repair or replacement of the defective product as described above.
- (2) ATD is not liable for any incidental damages, including but not limited to, lost profits and unforeseeable consequences.
- (3) The repair and replacement of this product under the express limited warranty described above is your exclusive remedy and is provided in lieu of all other warranties, express or implied. All other warranties, including implied warranties and warranties of merchantability or fitness for a particular purpose are disclaimed and, if disclaimer is prohibited, these warranties are limited to one year from your date of purchase of this product.

Some states' laws do not allow limited durations on certain implied warranties and some states' laws do not allow limitations on incidental or consequential damages. You should consult the law in your state to determine how your rights may vary.

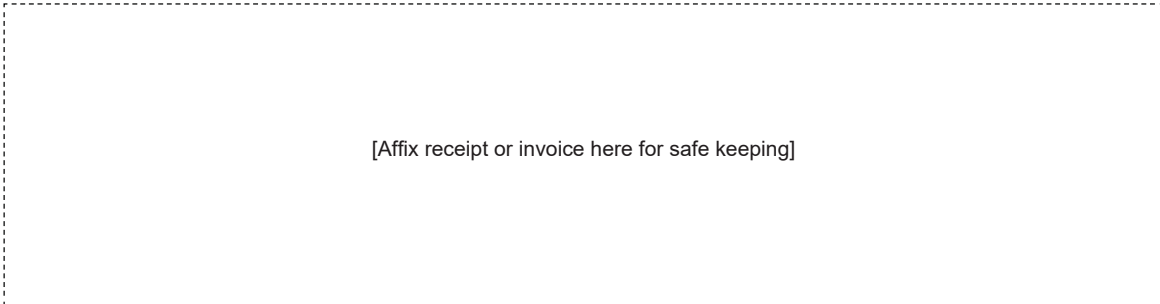

[Affix receipt or invoice here for safe keeping]