



ATD-7514 4-TON SERVICE JACK OWNER'S MANUAL



4-Ton Service Jack

Features:

- Exclusive Swift Lift Technology™ offers a quicker lift for professional performance
- High maximum lift is ideal for SUVs, trucks, trailers and other high clearance vehicles
- Dual pump pistons are shielded to prevent contaminants from damaging the hydraulic system
- Internal by-pass valve protects the hydraulic system from over pumping
- U-Joint release mechanism provides precise control of load descent in any handle position
- Heavy gauge construction features rolled edges for added strength
- Industrial grade casters offer greater stability and allow increased maneuverability and easy positioning of the jack
- Full cover rubber saddle pad protects the vehicle from damage during lifting
- Meets or exceeds ASME/PASE 2019 standards

Specifications:

- Capacity: 4 Tons
- Lifting Range: 4-7/16" - 19-7/8"
- Saddle Diameter: 4" with saddle pad
- Handle Length: 49-1/4" (2 piece) with protective foam
- Jack Size: 28-1/4" x 13-5/8" x 7-7/16"

Service Jack Model Number: ATD-7514

Capacity	Min. Height	Max Height	Jack Size (L x W x H)	Saddle Diameter	Net Weight
4 Ton	4-7/16"	19-7/8"	28-1/4" x 13-5/8" x 7-7/16"	4"	85.8 LB

SAFETY & WARNING INFORMATION



This is the safety notification symbol. This symbol will notify you of any potential injury hazards. Please follow all instructions that follow this symbol to avoid possible injuries or death.



Indicates a hazardous situation. If proper steps are not followed, death or serious injury could result.



IMPORTANT: READ ALL INSTRUCTIONS BEFORE USE

Before operating this device, be sure to read all content within this manual, ensuring that you understand the operating procedures, maintenance requirements and all safety warnings.

The owner and/or operator should have an understanding of the product, its operating characteristics, and safety operating instructions before operating this device. Safety information should be emphasized and understood. If the operator is not fluent in English, the product and safety instructions should be read to and discussed with the operator in the operator's native language by the purchaser/owner or his designee, making sure that the operator comprehends their contents.



ACTIONS TO HELP PREVENT DANGEROUS SITUATIONS

- Study, understand, and follow all instructions before operating this device.
- Do not exceed the rated capacity stated.
- Use only on hard level surfaces.
- This jack is to be used as a lifting device only. Immediately after lifting, support the vehicle with appropriate means.
- Do not move or dolly the vehicle while it is on the jack.
- Lift only on areas of the vehicle as specified by the vehicle manufacturer.
- No alterations should be made to this product.

SAFETY & WARNING INFORMATION (Continued)

- This jack is designed to raise the vehicle, not to support the weight on it's own once lifted. Support the vehicle with jack stands as outlined below.
- **Jack Stands** are designed to support stated capacity. Stands should only be used to support partial loads that consist of one end of a vehicle. Always use as a matched pair to support one end of a vehicle only.
- **Never** use jack stands to support **both ends** or **one side** of a vehicle.
- Use only **one (1) pair** of stands per vehicle.

SETUP, OPERATION & PREVENTIVE MAINTENANCE



SETUP

- Prior to each use, visual inspection (See Pg. 6) should be made to the device by checking for abnormal conditions, such as cracked welds, leaks, and damaged, loose, or missing parts.
- Consult the vehicle owner's manual to determine the location of lift points.
- Be sure to set the vehicle in park with the emergency brake on and wheels securely chocked.
- Be sure that the vehicle and the jack are on a hard, level surface.



ASSEMBLY

Service Jack

- Assemble the upper section of the two piece handle into the lower section, line up the holes, insert and tighten the screw.
- Insert the bottom end of handle into handle fork and securely tighten the bolt and washer. Ensure the handle can turn freely.



LIFTING

- Turn the handle/release valve clockwise to the closed position. Do not over tighten.
- Position the jack under the specified lift point.
- Begin lifting by pumping the handle up and down.
- Immediately after lifting, insert safety pins into the appropriately rated jack stands and support the vehicle. NEVER support the vehicle with only the jack.
- Turn the handle/release valve slowly counterclockwise to lower the vehicle onto jack stands.

SETUP, OPERATION & PREVENTIVE MAINTENANCE (Continued)



LOWERING

- Turn the handle/release valve clockwise to the closed position. Do not over tighten.
- Pump the handle up and down to lift vehicle off jack stands.
- Remove the jack stands and safety pins. **DO NOT** get under or let anyone get under the vehicle while lowering.
- Turn the handle/release valve slowly counterclockwise to lower the vehicle onto the ground.



SERVICE JACK MAINTENANCE

NOTICE: Use high grade hydraulic oil only. Never use brake fluid, motor oil, transmission fluid, turbine oil or any other fluids. ISO-VG22 or equivalent hydraulic oil is recommended.

Check and Refill Oil

- With the jack in the fully lowered, level position, if unit cover is provided, remove unit cover, then remove oil filler plug.
- Proper oil level should be just covering inner cylinder as seen from the oil filler plug hole.
- Do not overfill. Always fill with new, clean hydraulic jack oil as recommended above.
- Reinstall oil filler plug, then reinstall unit cover.

Lubrication and Cleaning

- Periodically clean and lubricate all moving parts and pivot points.

Air Venting Procedures

- With the jack in the fully lowered position, release valve open, remove oil filler plug.
- Pump the handle rapidly several times. Reinstall oil filler plug.
- Turn the handle/release valve clockwise to the closed position.
- Pump the handle until the lift arm reaches maximum height and continue to pump several times to remove trapped air in the system.
- Turn the handle/release valve counterclockwise in one full turn and lower lift arm to the lowest position. Use force on saddle if necessary.
- Carefully and slowly loosen oil filler plug to release pressurized air.
- Repeat above steps until trapped air is completely vented.

DAMAGED EQUIPMENT

Any **service jack** that appears to be damaged in any way, is found to be worn, or operates abnormally **SHOULD BE REMOVED FROM SERVICE UNTIL REPAIRED**. It is recommended that necessary repairs be made by a manufacturer's or supplier's authorized repair facility if repairs are permitted by the manufacturer or supplier.

SETUP, OPERATION & PREVENTIVE MAINTENANCE (Continued)

Alterations

Because of potential hazards associated with this type of equipment, no alterations should be made to the product.

Attachments and Adapters

Only attachments and/or adapters supplied by the manufacturer should be used.

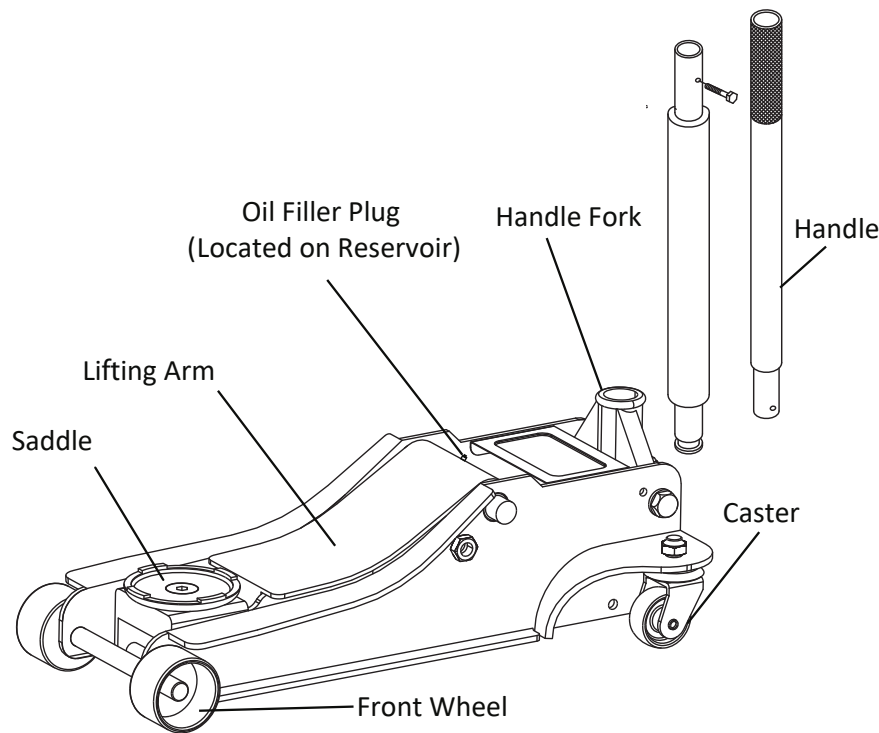

INSPECTION, STORAGE & TROUBLESHOOTING



INSPECTION

- Visual inspection should be made before each use of the device by checking for abnormal conditions, such as cracked welds, leaks, and damaged, loose, or missing parts.
- Other inspections should be made per product operating instructions.
- These devices should be inspected immediately if the device is believed to have been subjected to an abnormal load or shock. It is recommended that this inspection be made by a manufacturer's or supplier's authorized repair facility.
- Owners and/or operators should be aware that repair of this service jack may require specialized knowledge and facilities. It is recommended that an annual inspection of the product be made by a manufacturer's or supplier's authorized repair facility and that any defective parts, decals, or safety labels or signs be replaced with manufacturer's or supplier's specified parts.

INSPECTION, STORAGE & TROUBLESHOOTING (Continued)



STORAGE

The service jack and jack stands should be stored in a dry location on a level surface.



TROUBLESHOOTING

Symptom	Possible Causes	Solution
Jack will not lift the load.	<ol style="list-style-type: none"> 1. Release valve not tightly closed. 2. Low oil level. 3. Defective or worn internal parts. 4. Load exceeds maximum allowance. 	<ol style="list-style-type: none"> 1. Tighten release valve. 2. Check and add oil. Follow "Check and Refill Oil" instructions on Pg.4. 3. Discontinue use and contact a local repair center. 4. Use a higher capacity jack.
Jack will not hold the load.	<ol style="list-style-type: none"> 1. Release valve not tightly closed. 2. Power unit malfunction. 	<ol style="list-style-type: none"> 1. Tighten release valve. 2. Discontinue use and contact a local repair center.
Jack will not descend to minimum height, or will not remain in lowered position.	<ol style="list-style-type: none"> 1. Air trapped in system. 2. Reservoir oil overfilled. 	<ol style="list-style-type: none"> 1. Vent air out of system. Follow "Air Venting Procedures" on Pg. 4. 2. Check and ensure proper oil level. Follow "Check and Refill Oil" instruction on Pg.4.
Jack will not lift to max height.	<ol style="list-style-type: none"> 1. Low oil level. 	<ol style="list-style-type: none"> 1. Check and ensure proper oil level. Follow "Check and Refill Oil" instructions on Pg. 4.
Jack will not function properly after tried solution.	<ol style="list-style-type: none"> 1. Internal malfunction or structural damage. 	<ol style="list-style-type: none"> 1. Stop usage and contact an authorized repair center.

For assistance troubleshooting, please call our Toll Free Service Number 1-844-364-9922

EXPLODED VIEW & REPLACEABLE PART NUMBERS

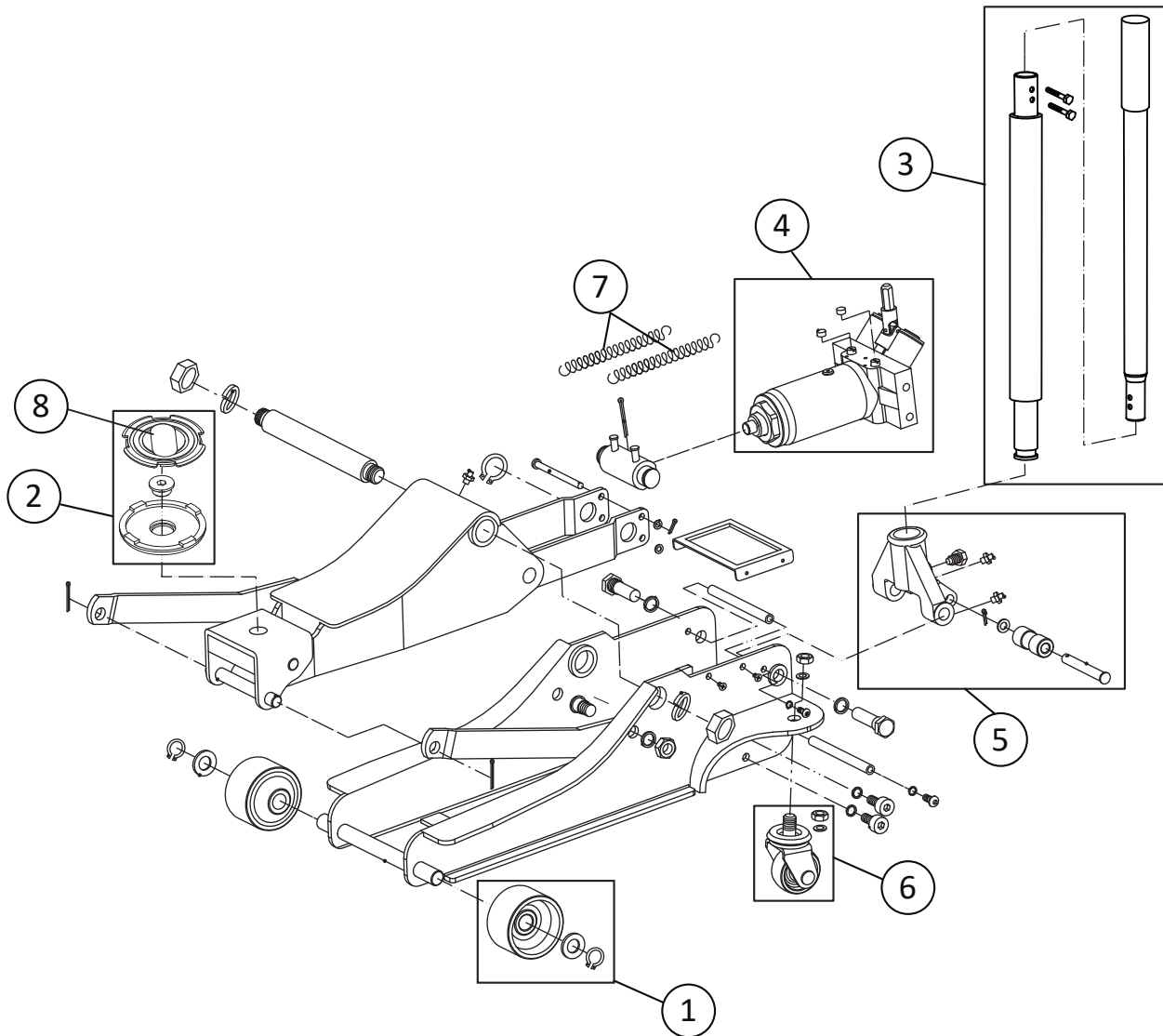

PART NO.	FACTORY NO.	DESCRIPTION	QTY
1	LYD3G-100	Front Wheel Assembly	2
2	LYD3G-PJ-2	Saddle W/ Pad	1
3	LYD3G-PJ-1A	Handle Assembly w/ Foam	1
4	LYD3G-PJ-4	Power Unit Assembly	1
5	LYD3F-500	Handle Fork Assembly	1
6	LYD3G-PJ-6	Rear Caster Assembly	2
7	LYD3A-5	Return Springs	2
8	LYD3A-8A	Saddle Pad	1
N/A	ATD7514-L	Product Label	1

* Items not identified by part number are not available for replacement.



THIS WARRANTY AND CONFIRMED RECEIPT(S) SHOULD BE RETAINED BY THE CUSTOMER AT ALL TIMES

PURCHASED FROM: _____

DATE PURCHASED: _____

INVOICE/RECEIPT NUMBER: _____

Your ATD-7514 is warranted for a period of 12 months from the original purchase date.

For a period of one (1) year from your purchase date, ATD Tools, Inc. will repair or replace (at its option) without charge, your ATD product if it was purchased new and the product has failed due to a defect in material or workmanship which you experienced during normal use of the product. This limited warranty is your exclusive remedy.

To access the benefits of this warranty, contact your supplier, or point of sale directly. You may be advised to return the product under warranty, freight prepaid, to your supplier for warranty determination.

If this ATD product is altered, abused, misused, modified, or undergoes service by an unauthorized technician, your warranty will be void. We are not responsible for damage to ornamental designs you place on this ATD product and such ornamentation should not cover any warnings or instructions or they may void the warranty. This warranty does not cover scratches, superficial dents, and other abrasions to the paint finish that occur under normal use. It also does not cover normal wear items such as but not limited to brushes, batteries, drill bits, drill chucks, pads or blades.

Subject to the law in your state:

- (1) Your sole and exclusive remedy is repair or replacement of the defective product as described above.
- (2) ATD is not liable for any incidental damages, including but not limited to, lost profits and unforeseeable consequences.
- (3) The repair and replacement of this product under the express limited warranty described above is your exclusive remedy and is provided in lieu of all other warranties, express or implied. All other warranties, including implied warranties and warranties of merchantability or fitness for a particular purpose are disclaimed and, if disclaimer is prohibited, these warranties are limited to one year from your date of purchase of this product.

Some states' laws do not allow limited durations on certain implied warranties and some states' laws do not allow limitations on incidental or consequential damages. You should consult the law in your state to determine how your rights may vary.

[Affix receipt or invoice here for safe keeping]