



# Hydraulic Long Ram

## Operating Instructions & Parts Manual

**Model Number**  
**ATD-7486**

**Capacity**  
**8 Ton**

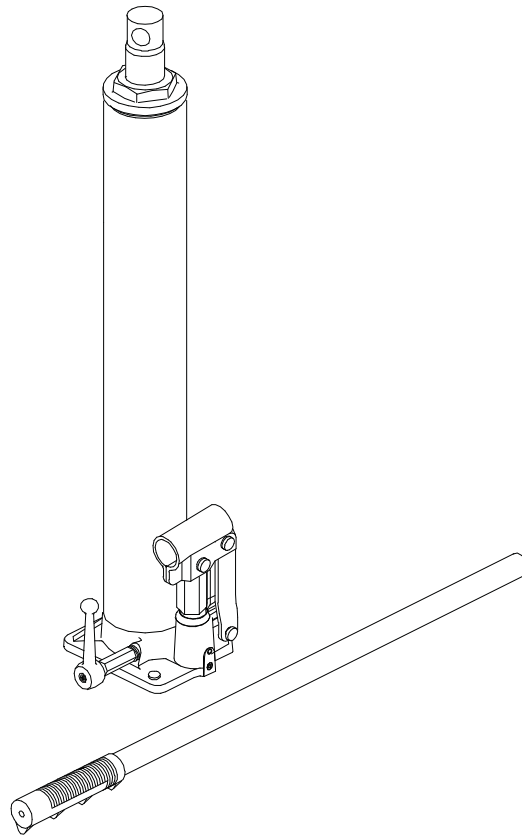

### **⚠ WARNING ⚠**

**WARNING:** This product may contain chemicals, including lead, known to the State of California to cause cancer, birth defects or other reproductive harm. *Wash hands after handling.*

Made in China to ATD Tools, Inc. Specifications  
Visit us at [www.atdtools.com](http://www.atdtools.com)

Printed In China  
ATD7486\_rev\_0417

**Save these instructions.** For your safety, read and understand the information contained within. The owner and operator shall have an understanding of this product and safe operating procedures before attempting to use this product. Instructions and Safety information shall be conveyed in the operators native language before use of this product is authorized. Make certain that the operator thoroughly understands the inherent dangers associated with the use and misuse of the product. If any doubt exists as to the safe and proper use of this product as outlined in this factory authorized manual, remove from service until which time it is clear. **Inspect before each use.** Do not use if broken, bent, cracked or otherwise damaged parts are noted. If the jack has been or suspected to have been subjected to a shock load, discontinue use until checked out by an authorized factory service center. Owners and operators of this equipment shall be aware that the use and subsequent repair of this equipment may require special training and knowledge. It is recommended that an annual inspection be done by qualified personnel and that any missing or damaged parts, decals, warning / safety labels or signs be replaced with factory authorized replacement parts only. Any jack that appears to be damaged in any way, is worn or operated abnormally should be removed from service immediately until such time as repairs can be made.

### PRODUCT DESCRIPTION

ATD Tools Hydraulic Long Ram is designed to be used only with corresponding ATDTools Engine Cranes. Its intended use is as an aid in the removal and installation of vehicle component parts and assemblies, particularly vehicle engines and those vehicle transaxles designed to be removed from above the engine compartment.

### SPECIFICATIONS

Model	Capacity	Base Size (L x W)	Min. Height	Max. Height
ATD-7486	8 Ton	5" x 4-3/4"	24-1/8"	43-1/4"

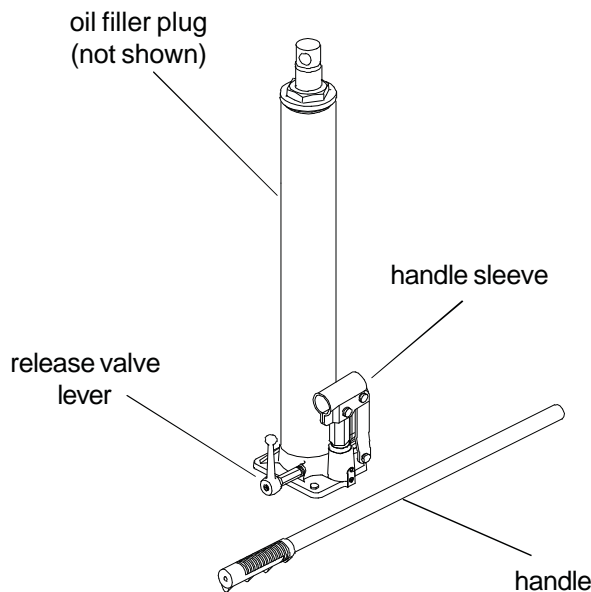

**⚠ WARNING**

**DO NOT USE AS AN INDEPENDENT LIFTING DEVICE. DO NOT OVERLOAD BEYOND RATED CAPACITY. AVOID SHOCK LOADS CAUSED BY RAPIDLY OPENING AND CLOSING RELEASE VALVE. DO NOT OPEN OIL FILLER PLUG UNLESS RAM IS FULLY LOWERED. MOVE OR DOLLY THE LOAD WITH CRANE IN LOWEST POSITION ONLY AND THEN ONLY ON HARD LEVEL SURFACES CAPABLE OF SUSTAINING THE LOAD. ENSURE THAT ALL MOUNTING HARDWARE IS TIGHT BEFORE USING. READ AND UNDERSTAND ALL INSTRUCTIONS PROVIDED WITH THIS JACK. FAILURE TO HEED THESE WARNINGS MAY RESULT IN LOSS OF LOAD, PERSONAL, EVEN FATAL INJURY AS WELL AS PROPERTY DAMAGE.**

Figure 1 - Model ATD-7486 nomenclature

## OPERATION

1. Secure jack to suitable engine crane. Locate and close release valve by turning lever clockwise firmly.
2. Operate by pumping handle until engine crane hook reaches desired position.
3. Lower hook by gently turning the release valve lever counter clockwise, **never more than 1/2 turn**. The release valve system is metered, so please be careful when lowering load.

## CAUTION

**BE SURE ALL TOOLS AND PERSONNEL ARE CLEAR BEFORE LOWERING LOAD. DANGEROUS DYNAMIC SHOCK LOADS ARE CREATED BY QUICKLY OPENING AND CLOSING THE RELEASE VALVE AS THE LOAD IS BEING LOWERED. THE RESULTING OVERLOAD MAY CAUSE HYDRAULIC SYSTEM FAILURE WHICH COULD CAUSE SEVERE PERSONAL INJURY AND/OR PROPERTY DAMAGE.**

## MAINTENANCE

**Important:** Use only a good grade hydraulic jack oil. Avoid mixing different types of fluid and NEVER use brake fluid, turbine oil, transmission fluid, motor oil or glycerin. Improper fluid can cause premature failure of the jack and the potential for sudden and immediate loss of load.

## Adding Oil:

1. With ram fully lowered and pump piston fully depressed, set jack in its upright, level position. Carefully remove from crane. Remove oil filler plug.
2. Fill until oil is level with the filler plug hole, re-install oil filler plug.

## Changing Oil:

For best performance and longest life, replace the complete fluid supply at least once per year.

1. With ram fully lowered and pump piston fully depressed, remove the oil filler plug.
2. Lay the jack on its side and drain the fluid into a suitable container.

**Note: Dispose of hydraulic fluid in accordance with local regulations.**

3. Set jack in its level upright position.
4. Fill with good quality jack oil. We recommend Mobil DTE 13 or equivalent. Reinstall oil filler plug.

## Lubrication

1. A coating of light lubricating oil to pivot points, axles and hinges will help to prevent rust and assure that wheels, casters and pump assemblies move freely.
2. Periodically check the pump piston and ram for signs of rust or corrosion. Clean as needed and wipe with an oily cloth.

**NEVER USE SANDPAPER OR ABRASIVE MATERIAL ON THESE SURFACES!**

3. When not in use, store the jack with pump piston and ram fully retracted.

## TROUBLESHOOTING

Symptom	Possible Causes	Corrective Action
Jack will not lift load	Release valve not tightly closed Overload condition	Ensure release valve tightly closed Remedy overload condition
Jack bleeds off after lift	Release valve not tightly closed Overload condition Hydraulic unit malfunction	Ensure release valve tightly closed Remedy overload condition Contact Tech. Service (888) 332-6419
Jack will not lower after unloading	Reservoir overfilled Linkages binding	Drain fluid to proper level Clean and lubricate moving parts
Poor lift performance	Fluid level low Air trapped in system	Ensure proper fluid level With ram fully retracted, remove oil filler plug to let pressurized air escape, reinstall oil filler plug
Will not lift to full extension	Fluid level low	Ensure proper fluid level

## ONE YEAR LIMITED WARRANTY

For a period of one (1) year from date of purchase, **ATD Tools, Inc.** will repair or replace, at its option, without charge, any of its products which fails due to a defect in material or workmanship, or which fails to conform to any implied warranty not excluded hereby.

Performance of any obligation under this warranty may be obtained by contacting your distributor or point of sale for further instructions. Please retain your proof of purchase, as it will be needed for any claim.

Except where such limitations and exclusions are specifically prohibited by applicable law, (1) the CONSUMER'S SOLE AND EXCLUSIVE REMEDY SHALL BE THE REPAIR OR REPLACEMENT OF DEFECTIVE PRODUCTS AS DESCRIBED ABOVE, and (2) **ATD Tools, Inc.** SHALL NOT BE LIABLE FOR ANY CONSEQUENTIAL OR INCIDENTAL DAMAGE OR LOSS WHATSOEVER, and (3) THE DURATION OF ANY AND ALL EXPRESSED AND IMPLIED WARRANTIES, INCLUDING WITHOUT LIMITATION, ANY WARRANTIES OF MERCHANTABILITY AND FITNESS FOR A PARTICULAR PURPOSE, IS LIMITED TO A PERIOD OF ONE (1) YEAR FROM DATE OF PURCHASE.

Some states do not allow limitations on how long an implied warranty lasts, so the above limitation may not apply to you. Some states do not allow the exclusion or limitation of incidental or consequential damages, so the above limitation or exclusion may not apply to you. This warranty gives you specific legal rights, and you may also have other rights which vary from state to state.

## REPLACEMENT PARTS

Available Parts: Please refer to the parts drawing when ordering parts. Not all components of the jack are replacement items, but are illustrated as a convenient reference of location and position in the assembly sequence. When ordering parts, give model number, serial number and description below. Call your distributor for current pricing.

Model # ATD-7486

<u>Parts No.</u>	<u>Description</u>	<u>Quantity</u>
1	oil filler plug	1
2	release valve assembly	1
3	handle assembly	1

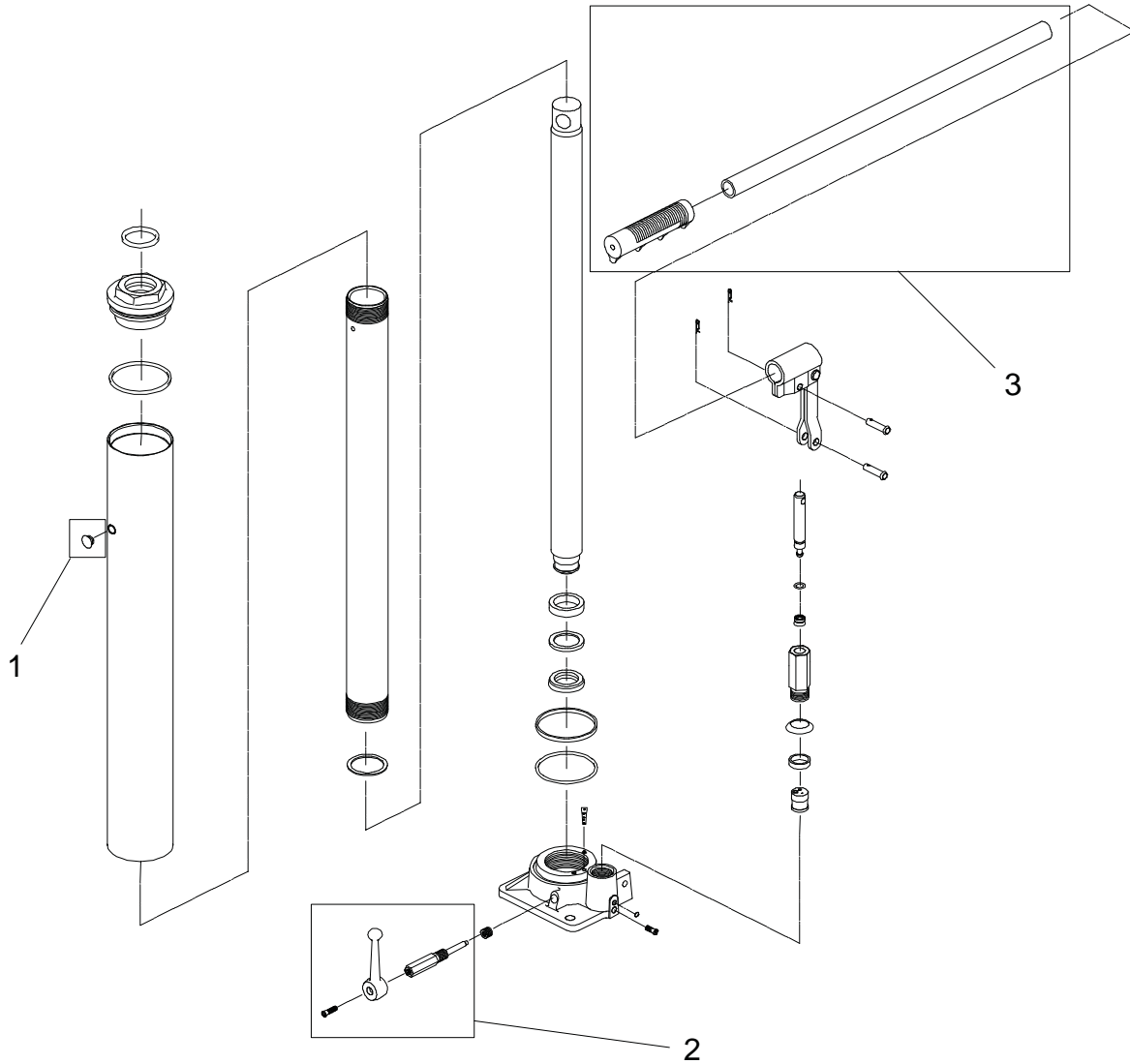

Figure 2 - Replacement Parts Illustration for model ATD-7486



