



ATD-7482A

1,250 Lbs. U-Style Engine Stand

Owner's Manual



Features:

- All ATD engine stands are constructed from heavy gauge, welded, square tubular steel and feature extra-long handle with rubber grips for easy rotation and maneuvering
- Meets or exceeds ASME / PASE 2019 standards

Specifications:

- Capacity: 1,250 lbs.
- Base Size: 33-3/8" x 33-5/8"
- Overall Height: 37"
- Head Plate Expansion: 7-1/2" x 10-1/2"
- Head Plate Dimensions: 10" x 6" x 5/8"
- Mounting Arm Dimensions: 3/4" diameter x 5" depth
- Wheel Diameter: 3-1/2"
- Handle Length: 13-3/4"

Save these instructions. For your safety, read and understand the information contained within. The owner and operator should have an understanding of this product and safe operating procedures before attempting to use this product. Instructions and Safety information should be conveyed in the operator's native language before use of this product is authorized. Make certain that the operator thoroughly understands the inherent dangers associated with the use and misuse of the product. If any doubt exists as to the safe and proper use of this product as outlined in this factory authorized manual, remove from service until which time it is clear. **Inspect before each use.** Do not use if broken, bent, cracked or otherwise damaged parts are noted. If the stand has been or suspected to have been subjected to a shock load, discontinue use until checked out by an authorized factory service center. Owners and operators of this equipment should be aware that the use and subsequent repair of this equipment may require special training and knowledge. It is recommended that an annual inspection be done by qualified personnel and that any missing or damaged parts, decals, warning / safety labels or signs be replaced with factory authorized replacement parts only. Any stand that appears to be damaged in any way, is worn or operated abnormally should be removed from service immediately until such time as repairs can be made.

PRODUCT DESCRIPTION

ATD Tools Engine Stands are designed to safely support rated capacity engines. Welded steel tube construction, heavy gauge steel head plates and mounting arms along with compliance with the latest **ASME/PASE** standards ensure safety, strength and stability. Each model comes with a head plate lock which helps prevents inadvertant rotation of engine. Model # ATD-7482A base has U-shaped construction. The U-shape allows even greater stability of loads up to 1,250 lbs.

SPECIFICATIONS

Model	Capacity	Base Size (L x W)	Overall Height	Head Plate	Head Plate Expansion	Wheel Diameter	Handle Length	Weight
ATD-7482A	1,250 lbs.	33-3/8" x 33-5/8"	37"	10" x 6" x 5/8"	7-1/2" - 10-1/2"	3-1/2"	13-3/4"	77 lbs.

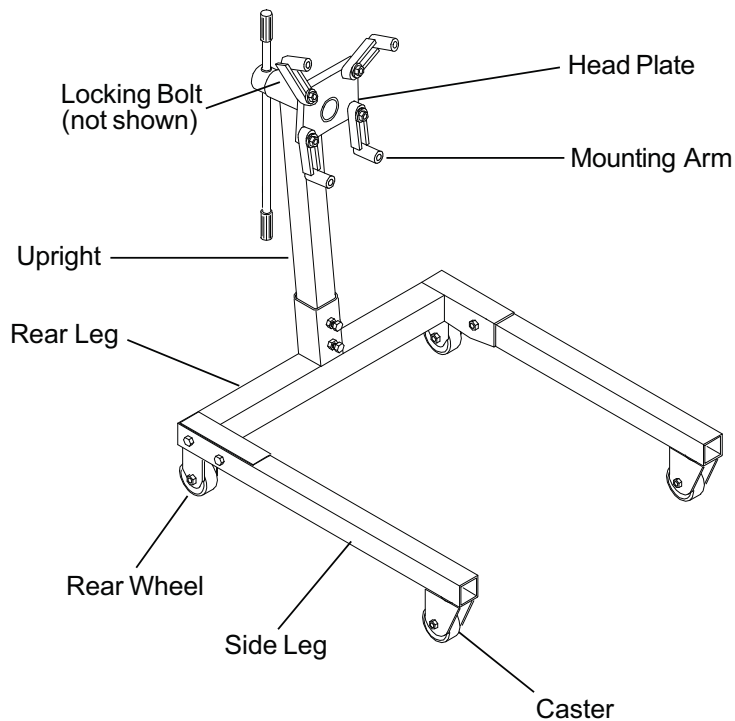

Figure 1 - Model ATD-7482A Engine Stand components

ASSEMBLY

1. Attach wheel (20) to bracket (15) with bolt, washer & nut (16,17 & 18).
2. Attach caster (22) to side leg with bolt & washer (23 & 17).
3. Attach center beam (25) to side legs (24) with two bolts & washers (14 & 13) each.
4. Attach upright (7) to center beam (25) with two bolts (8).
5. Place head plate assembly (6) into collar of upright (7). Insert bolt (21) to fasten head plate assembly.
6. Attach all four mounting arms (4) to head plate (6) with bolt, flat washer, lock washer & nut (5, 3, 2 & 1) each.
7. Insert handle (10) into hole of head plate assembly (6). Place handle grip (9) on each end of handle.

NOTICE: Check all fasteners for tightness, tighten where required.

Size of Hardware		Qty
5-Bolt	M14X60	4
3-Flat Washer	M14	4
2-Lock Washer	M14	4
1-Nut	M14	4
8-Bolt	M12X25	4
11-Nut	M12	4
12-Lock Washer	M12	6
13-Flat Washer	M12	6
14-Bolt	M12X85	4
16-Bolt	M8X55	2
17-Lock Washer	M8	10
18-Nut	M8	10
23-Bolt	M8X16	8

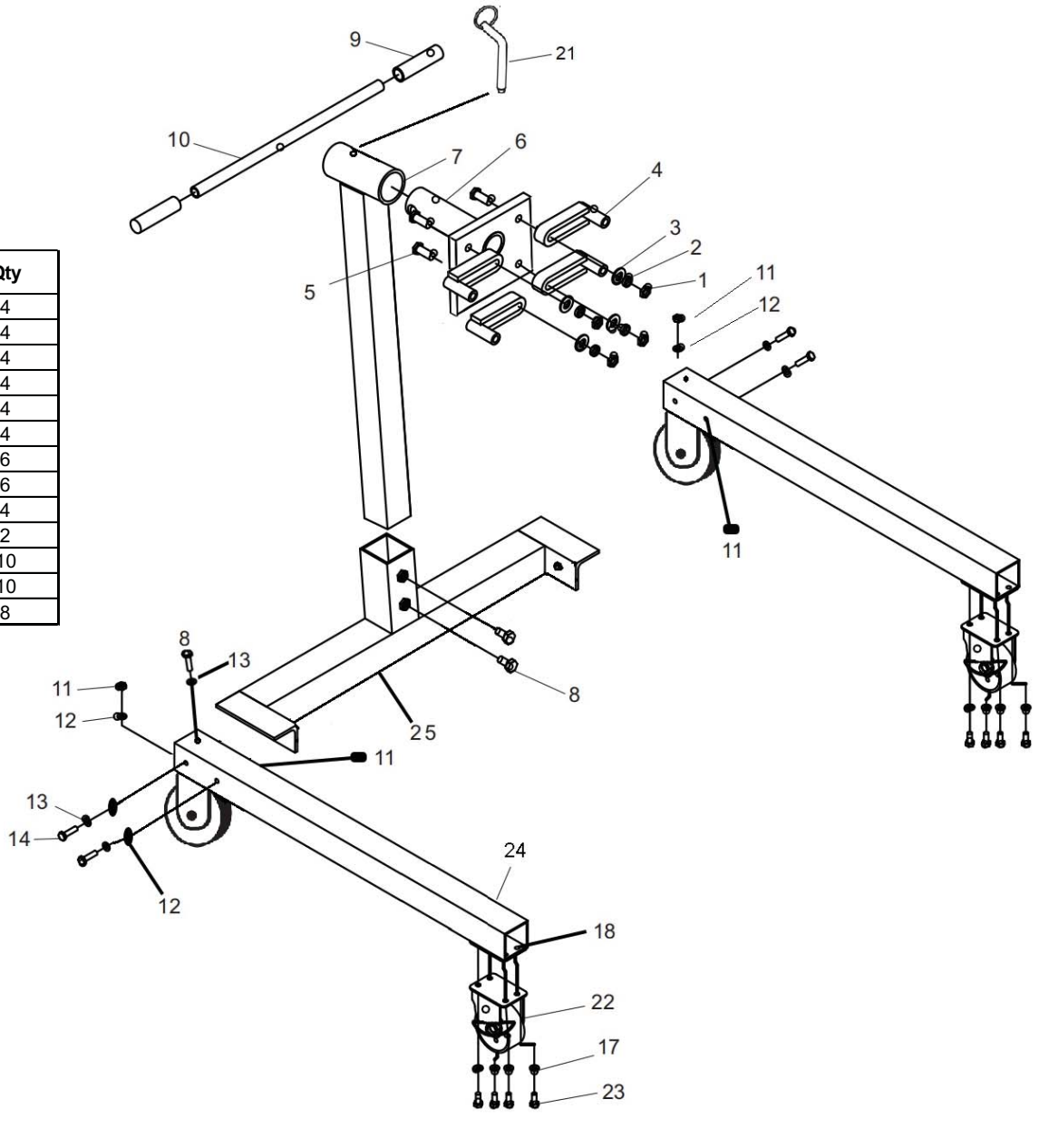

Figure 2 - Assembly Illustration for Model ATD-7482A

WARNING

FAMILIARIZE YOURSELF THOROUGHLY WITH PRODUCT. READ AND UNDERSTAND OWNER'S MANUAL BEFORE USE. USE ON HARD LEVEL SURFACES CAPABLE OF SUSTAINING RATED CAPACITY LOADS. DO NOT OVERLOAD BEYOND RATED CAPACITY. LOCK ROTATING DEVICE BEFORE APPLYING LOAD. *MOVE LOADED STAND CAREFULLY AND ONLY OVER LEVEL, SMOOTH SURFACES. ROTATE ENGINE SLOWLY, CAREFULLY.* TAKE EVERY NECESSARY PRECAUTION TO ENSURE YOUR SAFETY. OFF CENTER LOADS MAY CAUSE THE STAND TO TIP OR FLIP VIOLENTLY. DO NOT MODIFY STAND OR SUBSTITUTE HARDWARE. NEVER USE THIS PRODUCT FOR ANY PURPOSE OTHER THAN THAT FOR WHICH IT IS DESIGNED. NEVER ADD EXTENSION DEVICE TO ADAPTER BARS. FAILURE TO HEED THIS WARNING MAY RESULT IN SEVERE INJURY AND/OR PROPERTY DAMAGE.

BEFORE USE

1. Inspect stands before each use. Do not use if bent, broken or cracked components are noted. Ensure that casters / wheels and head plate rotate freely. Check for and tighten any loose assemblies.
2. Verify that the product and the application are compatible.
3. Before using this product, read the owner's manual completely and familiarize yourself thoroughly with the product and the hazards associated with its improper use.

OPERATION

1. Ensure application is compatible with product.
2. Align engine with stand, then adjust mounting arms to match bell housing mounting bolt holes. **Rotational lock must be secure before applying load.**
3. Carefully secure engine so that load is centered on stand. Secure with suitable high strength stud bolts and flat washers. **Ensure threads are compatible with your engine.** Use flat washers on both sides of head plate.
4. To rotate engine, loosen bolt. Use handle to rotate, then secure with rotational locking device.
5. Check to ensure stand is secure before working on or around stand. **NEVER WORK UNDER LOADED STAND.**

NOTE: DO NOT MOVE LOADED STAND OFF HARD SMOOTH, LEVEL SURFACE!



MAINTENANCE

Periodically inspect each stand. Ensure all parts move freely. Apply very light coating of grease to head plate collar. If rust appears, sand affected area and cover with suitable utility paint.

REPLACEMENT PARTS

Not all components of this product are replacement items, but are illustrated as a convenient reference for position in the assembly sequence. When ordering parts, give model number, part number and description. Call your distributor for current pricing:

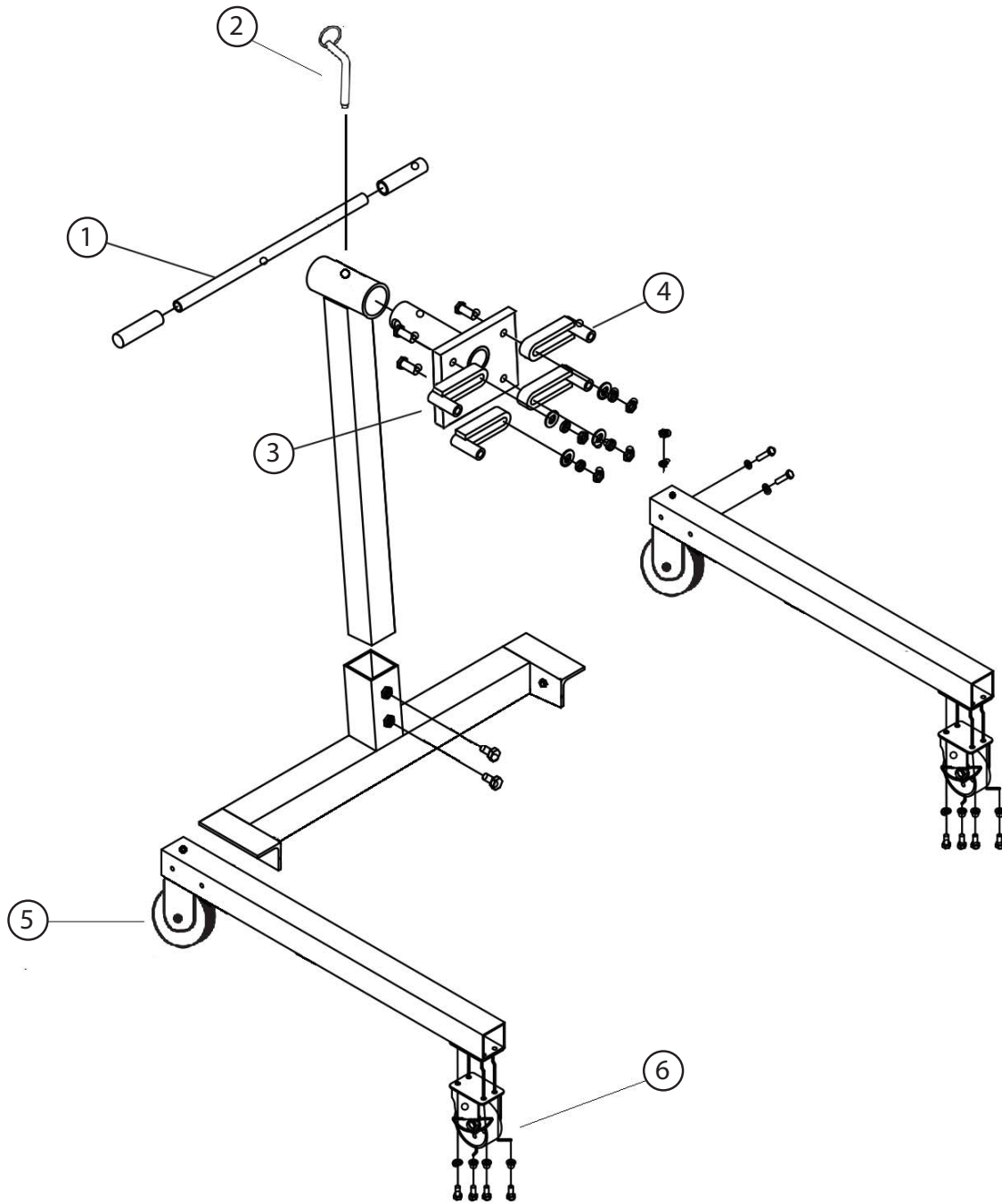

ITEM#	ORDERING PART#	PART DESCRIPTION	QTY
1	PRT7482A-01	HANDLE	1
2	PRT7482A-02	LOCKING BOLT	4
3	PRT7482A-03	HEAD PLATE	4
4	PRT7482A-04	MOUNTING ARM	4
5	PRT7482A-05	WHEEL	2
6	PRT7482A-06	CASTER, 3-1/2"	2

Figure 3 - Replacement Parts Illustration for model ATD-7482A



WARRANTY
1 YEAR LIMITED WARRANTY

THIS WARRANTY AND CONFIRMED RECEIPT(S) SHOULD BE RETAINED BY THE CUSTOMER AT ALL TIMES

PURCHASED FROM: _____

DATE PURCHASED: _____

INVOICE/RECEIPT NUMBER: _____

Your ATD-7482A is warranted for a period of 12 months from the original purchase date.

For a period of one (1) year from your purchase date, ATD Tools Inc. will repair or replace (at its option) without charge, your ATD product if it was purchased new and the product has failed due to a defect in material or workmanship which you experienced during normal use of the product. This limited warranty is your exclusive remedy.

To access the benefits of this warranty, contact your supplier, or point of sale directly. You may be advised to return the product under warranty, freight prepaid, to your supplier for warranty determination.

If this ATD product is altered, abused, misused, modified, or undergoes service by an unauthorized technician, your warranty will be void. We are not responsible for damage to ornamental designs you place on this ATD product and such ornamentation should not cover any warnings or instructions or they may void the warranty. This warranty does not cover scratches, superficial dents, and other abrasions to the paint finish that occur under normal use. It also does not cover normal wear items such as but not limited to brushes, batteries, drill bits, drill chucks, pads or blades.

Subject to the law in your state:

- (1) Your sole and exclusive remedy is repair or replacement of the defective product as described above.
- (2) ATD is not liable for any incidental damages, including but not limited to, lost profits and unforeseeable consequences.
- (3) The repair and replacement of this product under the express limited warranty described above is your exclusive remedy and is provided in lieu of all other warranties, express or implied. All other warranties, including implied warranties and warranties of merchantability or fitness for a particular purpose are disclaimed and, if disclaimer is prohibited, these warranties are limited to one year from your date of purchase of this product.

Some states' laws do not allow limited durations on certain implied warranties and some states' laws do not allow limitations on incidental or consequential damages. You should consult the law in your state to determine how your rights may vary.

[Affix receipt or invoice here for safe keeping]