

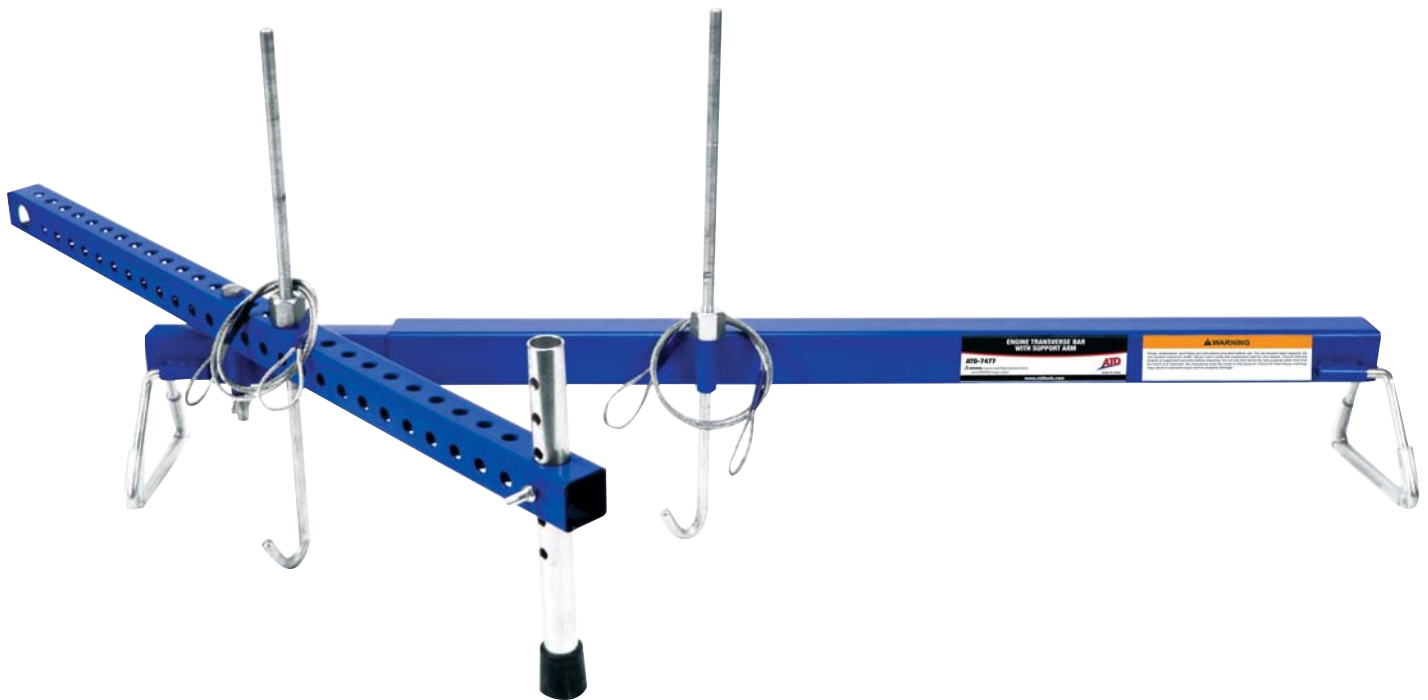

ATD-7477

Engine Transverse Bar with Support Arm

Owner's Manual



Features:

- (2) 14" adjustable hook screws
- 700 lbs. capacity adjustable transverse bar
- Width expands from 38" to a full 61"

Specifications:

- Capacity: 700 lbs.
- Hook Thread Length: 12-1/2"
- Shipping Weight: 28 lbs.

Save these instructions. For your safety, *read, understand and follow* the information contained within. The owner and operator should have an understanding of this product and safe operating procedures before attempting to use this product. Instructions and Safety information should be conveyed in the operator's native language before use of this product is authorized. Make certain that the operator thoroughly understands the inherent dangers associated with the use and misuse of the product. If any doubt exists as to the safe and proper use of this product as outlined in this factory authorized manual, remove from service. **Inspect before each use.** Do not use if there are broken, bent, cracked or otherwise damaged parts (including labels). Owners and operators of this equipment should be aware that the use of this equipment may require special training and knowledge. It is recommended that an annual inspection be done by qualified personnel and that any missing or damaged decals, warning / safety labels or signs be replaced with factory authorized replacements only. Any engine transverse bar that appears to be damaged in any way, is worn or operates abnormally should be removed from service immediately.

PRODUCT DESCRIPTION

ATD Tools Engine Transverse Bar is designed to safely support engines up to 700 lbs. It assists the removal of transaxle by supporting the engine of a front wheel drive vehicle. Heavy-duty steel frame helps prevent distortion and twisting. Compliance with factory standards ensures safety, strength and stability.

SPECIFICATIONS

Model	Capacity	Width Expand	Hook Thread Length	Shipping Weight
ATD-7477	700 lbs.	38"- 61"	12-1/2"	28 lbs.

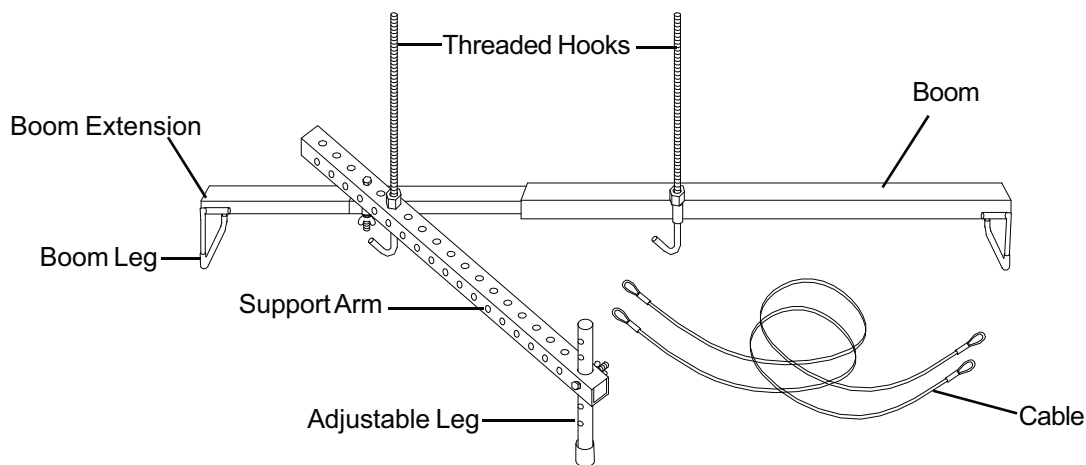

Figure 1 - Engine Transverse Bar components

BEFORE USE

1. Verify that the product and the application are compatible.
2. Before using this product, read the operator's manual completely and familiarize yourself thoroughly with the product and the hazards associated with its improper use.
3. Inspect before each use. Do not use if bent, broken or cracked components are noted.
4. Ensure that all parts move freely.

⚠ **WARNING**

- Study, understand, and follow all instructions provided before attempting to use this equipment.
- Do not exceed rated capacity.
- Do not exceed maximum width.
- Never crawl under the suspended load for any reason.
- Ensure that the engine is supported securely before repairing.
- Do not use this device for any purpose other than that for which it is intended.
- No alterations shall be made to this product.
- Failure to heed these markings may result in personal injury and/or property damage.

ASSEMBLY (refer to Figure 2)

1. Insert the wide leg (#13) into tube welded at the end of boom (#1) and the narrow leg (#14) to boom extension (#2).
2. Slide transfer adapter (#11) over the end of boom extension (#2) with tube toward you.
3. Insert the boom extension (#2) into boom (#1).

NOTE: The Engine Transverse Bar may be used with or without support arm, depending on the load being supported.

4. To use without support arm: Secure both threaded hooks (#3) to the tube welded on boom and transfer adapter with barrel hex nut (#7). Thread the hex nut (#7) all the way down towards the hook portion to hold it out of the way until needed.
5. To use with support arm:
 - (a) Insert the adjustable leg (#6) into support arm (#10), then hand tighten with M8x65 bolt and wing nut (#9 & 8). Do not fully tighten wing nut as height adjustment may be necessary once the Engine Transverse Bar is placed over the engine compartment of the vehicle.
 - (b) After determining the support arm length needed, Connect the support arm (#10) to transfer adapter (#11) on the boom extension with M12x120 bolt and wing nut (#5 & 4). Again, do not fully tighten as some length adjustment may be required.
 - (c) Before placing the Engine Transverse Bar over the engine compartment, install the two threaded hooks (#3) provided. Insert one hook into the tube welded on boom (#1) and secure with barrel hex nut (#7). Thread the hex nut (#7) all the way down towards the hook portion to hold it out of the way until needed. Then, locate the best position on the support arm for the second hook and install in the same manner.
6. Now the Engine Transverse Bar is ready to use.

MAINTENANCE

Periodically inspect the Engine Transverse Bar. Ensure all parts move freely. To help prevent rust, wipe clean and/or blow dry after each use. If rust appears, sand affected area and cover with suitable utility paint. Store the Engine Transverse Bar in a clean, dry area.

OPERATION

1. Determine the location of the two engine support bolts on your vehicle. Then place the Engine Transverse Bar directly over these two bolts.
2. Adjust the boom extension (#2) to ensure that both legs (#13 & 14) are sitting inside the fender of the engine compartment.

▲ CAUTION: If the inside fender lips are more than 61" apart, the Engine Transverse Bar must not be used. Do not extend past the designated marking (61") as over-extending this unit may compromise the 700 lbs. capacity. This could cause the Engine Support Bar to collapse, resulting in personal injury or property damage.

3. Adjust to ensure the support arm (#10) is in correct position. The rubber tip of the adjustable leg (#6) should be on a flat, reinforced surface capable of supporting the weight of engine. Tighten both wing nuts (#4 & 8) to secure the adjustable leg (#6) and support arm (#10).
4. Lower the threaded hooks (#3) to appropriate position. Ensure that the hooks are directly over the engine support bolts or brackets; therefore the engine does not swing when vehicle is disassembled.
5. Attach the looped ends of the two 1/8" braided steel cables (#12) to the engine support bolts on the engine and loop middle of braided cables over hooks. If the engine being supported is equipped with engine lift brackets, hook the hooks (#3) directly into engine lift brackets for extra protection.

Note: Use only fasteners rated Grade 5 or higher as engine support bolts.

6. Tighten the barrel hex nuts (#7) on both hooks until cables are snug or hex nuts are tight against support bar.
7. Double check that engine is properly supported before removing transaxle.

REPLACEMENT PARTS (Refer to Figure 2 below)

Not all components of the Engine Transverse Bar are replacement items, but are illustrated as a convenient reference of location and position in the assembly sequence. When ordering parts, give model number, part number and description. Call your distributor for current pricing.

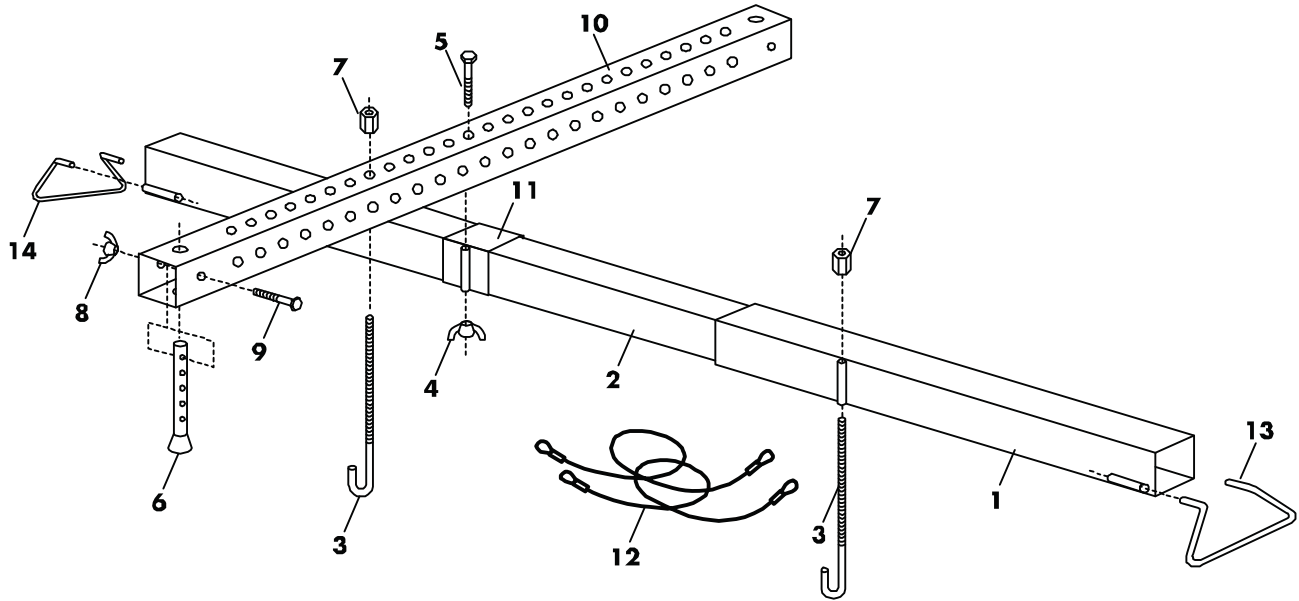

Figure 2 - Engine Transverse Bar Assembly & parts Illustration

Model ATD-7477

<u>Item</u>	<u>Part#</u>	<u>Description</u>	<u>Qty</u>	<u>Item</u>	<u>Part#</u>	<u>Description</u>	<u>Qty</u>
1	-	Boom	1	10	-	Support Arm	1
2	-	Boom Extension	1	11	-	Transfer Adapter	1
3	*	Threaded Hook	2	12	44700-12	Braided Steel Cable	2
4	*	Wing Nut, M12	1	13	44700-17	Leg, Wide	1
5	*	Hex Bolt, M12x120	1	14	44700-14	Leg, Narrow	1
6	44700-6	Adjustable Leg	1	*	44700-15	Hardware Kit	-
7	*	Barrel Hex Nut	2	-	ATD7477-L0	Label	-
8	*	Wing Nut, M8	1	-	ATD7477-M0	Manual	-
9	*	Hex Bolt, M8x65	1				

(*) Hardware Kit includes item#'s 3, 4, 5, 7, 8 & 9



WARRANTY
1 YEAR LIMITED WARRANTY

THIS WARRANTY AND CONFIRMED RECEIPT(S) SHOULD BE RETAINED BY THE CUSTOMER AT ALL TIMES

PURCHASED FROM: _____

DATE PURCHASED: _____

INVOICE/RECEIPT NUMBER: _____

Your ATD-7477 is warranted for a period of 12 months from the original purchase date.

For a period of one (1) year from your purchase date, ATD Tools Inc. will repair or replace (at its option) without charge, your ATD product if it was purchased new and the product has failed due to a defect in material or workmanship which you experienced during normal use of the product. This limited warranty is your exclusive remedy.

To access the benefits of this warranty, contact your supplier, or point of sale directly. You may be advised to return the product under warranty, freight prepaid, to your supplier for warranty determination.

If this ATD product is altered, abused, misused, modified, or undergoes service by an unauthorized technician, your warranty will be void. We are not responsible for damage to ornamental designs you place on this ATD product and such ornamentation should not cover any warnings or instructions or they may void the warranty. This warranty does not cover scratches, superficial dents, and other abrasions to the paint finish that occur under normal use. It also does not cover normal wear items such as but not limited to brushes, batteries, drill bits, drill chucks, pads or blades.

Subject to the law in your state:

- (1) Your sole and exclusive remedy is repair or replacement of the defective product as described above.
- (2) ATD is not liable for any incidental damages, including but not limited to, lost profits and unforeseeable consequences.
- (3) The repair and replacement of this product under the express limited warranty described above is your exclusive remedy and is provided in lieu of all other warranties, express or implied. All other warranties, including implied warranties and warranties of merchantability or fitness for a particular purpose are disclaimed and, if disclaimer is prohibited, these warranties are limited to one year from your date of purchase of this product.

Some states' laws do not allow limited durations on certain implied warranties and some states' laws do not allow limitations on incidental or consequential damages. You should consult the law in your state to determine how your rights may vary.

[Affix receipt or invoice here for safe keeping]