



Fuel Tank Adapter

Operating Instructions & Parts Manual

Model
ATD-7470

Capacity
80 lbs.

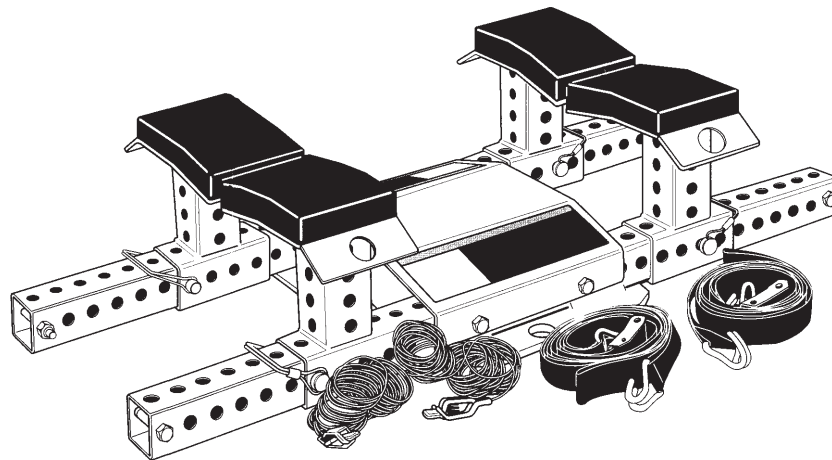

This is the safety alert symbol. It is used to alert you to potential personal injury hazards. Obey all safety messages that follow this symbol to avoid possible injury or death.

ADVERTENCIA

- Leer, comprender, y seguir las instrucciones antes de utilizar el aparato.
- El manual de instrucciones y la información de seguridad deben estar comunicados en lengua del operador antes del uso.
- No seguir estas indicaciones puede causar daños personales o materiales.

DANGER



Risk of Explosion! Use of this product requires special skills and knowledge pertaining to grounding and bonding of the components. Use **ONLY** on METAL FUEL TANKS!

WARNING

WARNING: This product may contain chemicals, including lead, known to the State of California to cause cancer, birth defects or other reproductive harm. **Wash hands after handling.**

SAFETY and GENERAL INFORMATION

Save these instructions. For your safety *read, understand, and follow* the information provided with and on this device before using. The owner and operator of this equipment shall have an understanding of it and safe operating procedures before attempting to use. The owner and operator shall be aware that use of this product requires special skills and knowledge pertaining to bonding and grounding of personnel and components. Instructions and safety information shall be conveyed in the operator's native language before use of this product is authorized. If any doubt exists as to the safe and proper use of this device, remove from service immediately.

Inspect before each use. Do not use if broken, bent, cracked, or damaged parts (including labels) are noted. Any Fuel Tank Adapter that appears damaged in any way, operates abnormally or is missing parts, shall be removed from service immediately. If you suspect that the product was subjected to a shock load (a load dropped suddenly, unexpectedly upon it), immediately discontinue use until it has been checked by a factory authorized service center (contact distributor or manufacturer for list of authorized service centers). It is recommended that an annual inspection be done by qualified personnel. Labels and Owner's manuals are available from manufacturer.

PRODUCT DESCRIPTION

This Fuel Tank Adapter is designed for fuel tank removal and fuel tank installation. This Fuel Tank Adapter must **ONLY** be secured to ATD Transmission Jack models ATD-7430, ATD-7431, ATD-7432, ATD-7433 and ATD-7434. It is designed for use with **passenger cars and light trucks only**. The Fuel Tank Adapter should only be used on **METAL FUEL TANKS**.

SPECIFICATIONS

Model	Capacity	Max. Fuel Tank Size	Product Size (L x W x H)	Net Weight
ATD-7470	80 lbs.	40 gal.	32" x 15-3/8" x 9-1/4"	49 lbs.

⚠ Risk of Explosion! Use of this product requires special skills and knowledge pertaining to grounding and bonding of the components. Use **ONLY** on **METAL FUEL TANKS!**

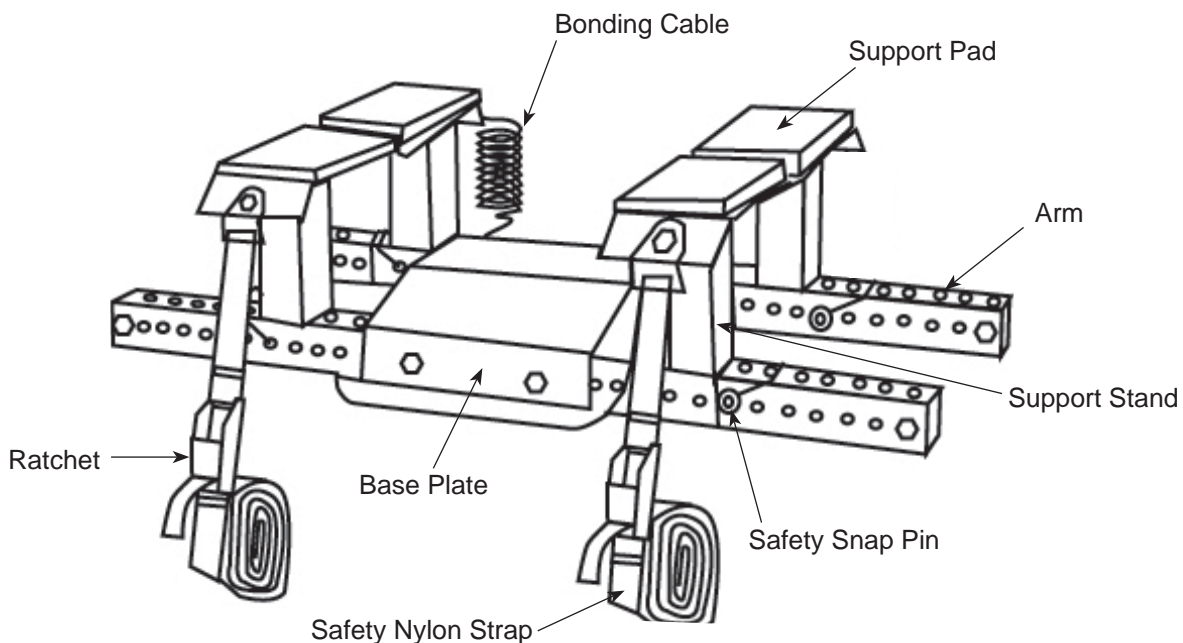

Figure 1 - Fuel Tank Adapter components

INSTALLATION (refer Figure 1 thru 5)

Note: Below instruction is illustrating the use of fuel tank adapter conjunction with models ATD-7430 and ATD-7431. (Installation is similar for ATD-7432, ATD-7433 & ATD-7434)

Estimated Time: 30 minutes

Tools required: Drill, 7/16" drill bit, 17mm & 19mm wrenches.

1. Remove saddle from the transmission jack.
2. Drill two 7/16" size holes on the saddle. Ensure the holes are 9-1/2" apart and, should be located equally away from the saddle edges about 1" (Refer figures 2 & 3 for location of holes).

Note: The integrity of your transmission jack should not be affected by these two holes as long as the instructions are followed. ATD warrants its transmission jack original warranty for this specific fuel tank adapter installation.

3. Secure the fuel tank adapter to the saddle with two 3/8"-24x1-1/2" bolts, flat washers, lock washers and nuts provided (Figure 4).

(Refer to Figure 5 for below procedures)

4. Slide support stand (1) over one end of the two arms (2). Repeat procedure on other end of same arm; Slide support stand (3) over one end of the other arm. Repeat procedure on other end of same arm.
5. Secure each support stand by inserting snap pin (4) through the aligned holes on arm, snapping the latch over the end of pin as shown.
6. Insert the 3/8"-16 x 2-1/2" bolt (5) through the last set of holes in arm and secure in place with washers, lockwasher and nut provided. Repeat for other three sides.
7. Secure both bonding cables (6) to the top side of frame base with 1/4"-20x1" bolt and nut provided.

Note: Remove paint from top and bottom of plate around the 1/4" diameter hole.

8. Bolt safety nylon strap (7) to support stand (3). Secure with 1/2"-13x1" bolt, washer, lockwasher and nut provided. Repeat procedure on other support stand.

9. The assembly is now ready to use.

Fig. 2

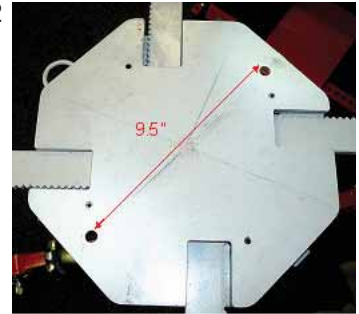

Fig. 3

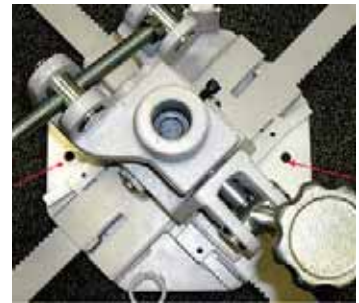

Fig. 4

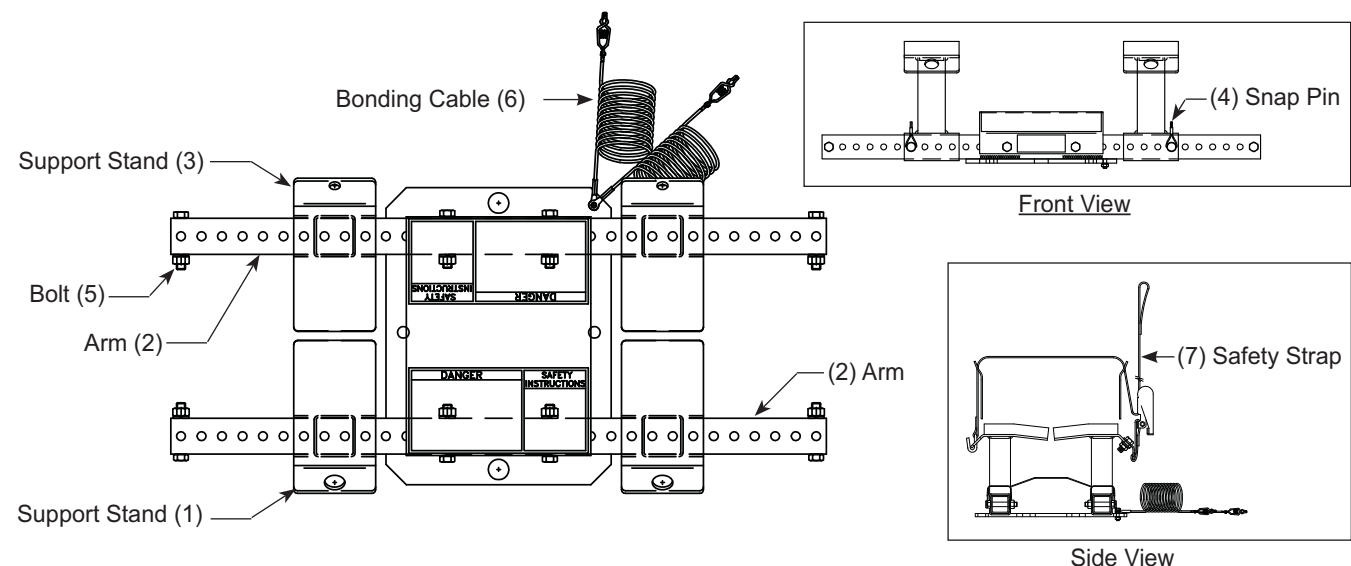



Figure 5 - Assembly Instruction

BEFORE USE

1. Verify that the product and the application are compatible.
2. Before using this product, read this fuel tank adapter manual, the transmission jack manual, and the vehicle service manual completely. Familiarize yourself thoroughly with the product, its components, and recognize the potential hazards associated with its use.
3. Locate and place a Class B fire extinguisher near the working area.
4. Affix the fuel tank adapter to transmission jack properly **before** removing or installing the fuel tank.
5. Bond the Fuel Tank Adapter to the transmission jack and to the fuel tank while grounding the transmission jack to earth before removing or installing the fuel tank. **Operator must be bonded to both the jack and tank!** If unsure how to provide proper grounding and bonding of personnel and equipment **STOP, discontinue use**, and seek the advice of qualified personnel.
6. Replace worn or damaged parts and assemblies with factory authorized replacement parts only.
7. Inspect before each use. Do not use if bent, broken or cracked components are noted.

! DANGER



 **NO SMOKING!**

- **NEVER** use fuel tank handler near open flame, heat sources or spark inducing environments.
- **ALWAYS** have a Class B fire extinguisher available.
- Drain **ALL** fuel from the vehicle fuel tank into an approved and grounded fuel storage tank. **NEVER** drain or store fuel in an open container, near open flames, heat sources, or spark inducing environments.
- If the fuel tank is damaged during servicing, **STOP** and discard the fuel tank.
- **Use ONLY on METAL FUEL TANKS! Do not use on plastic fuel tanks!**
- **FAILURE TO HEED THESE WARNINGS COULD RESULT IN DEATH, PERSONAL INJURY, AND/OR PROPERTY DAMAGE!**

! WARNING

- **Study, understand, and follow** all instructions provided with and on this device **before use**.
- Do not exceed rated capacity.
- **Use** the Fuel Tank Adapter **only with ATD Transmission Jack models: ATD-7430, ATD-7431, ATD-7432, ATD-7433 and ATD-7434.**
- **ALWAYS** bond the fuel tank to the transmission jack and bond the transmission jack to the earth using the two bonding cables provided.
- **ALWAYS** center fuel tank on the four support pads.
- **ALWAYS** secure fuel tank to fuel tank adapter using the provided safety nylon straps.
- The fuel tank and the Fuel Tank Adapter must be completely lowered (transmission jack ram fully retracted) before transporting.
- Do not use adapters or accessories that are not provided initially. Only accessories supplied by the manufacturer can be used.
- Do not modify this device.
- **Failure to heed these markings may result in personal injury and/or property damage.**

! WARNING

- The paint on this product contains lead, a chemical known in the State of California to cause cancer, birth defects and other reproductive harm.
- Do not ingest paint chips and keep product away from children.
- Wash hands after each use.

! Operator must be bonded to both the jack and tank! If unsure how to provide proper bonding of personnel and equipment **STOP, discontinue use**, and seek the advice of qualified personnel.

BEFORE USE

1. Verify that the product and the application are compatible, if in doubt call for Technical Assistance 888-332-6419.
2. Before using this product, read the operator's manual completely and familiarize yourself thoroughly with the product and the hazards associated with its improper use.
3. Inspect before each use. Do not use if bent, broken or cracked components are noted.
4. Ensure that all parts move freely.

OPERATION

Removal of Fuel Tank (Refer to Figure 6)

1. Read and follow the fuel tank removal/installation procedures as stated in the vehicle service manual.
2. Drain the existing fuel into an approved and grounded fuel storage tank.
3. Raise the transmission jack to directly underneath the designated fuel tank, refer to your transmission jack owner/operator's manual for instructions on how to raise and lower the transmission jack.



Operator must be bonded to both the jack and tank! If unsure how to provide proper bonding of personnel and equipment **STOP, discontinue use**, and seek the advice of qualified personnel.

4. Clip one bonding cable to the fuel tank.
5. Clip the other bonding cable to the transmission jack.
6. Ground the transmission jack to earth.
7. Center the fuel tank on all four of the Fuel Tank Adapter padded supports. For adjustment:
 - a. Open the latch of the safety snap pin and remove.
 - b. Slide the support stand to the desired location.
 - c. Re-insert safety snap pins through the holes in both the support stand and arm. Close the latch of snap pin.
 - d. Adjust the opposite support stand to match the previously repositioned support stand.
 - e. Ascertain that the load is centered with respect to the transmission jack.
8. Place the safety nylon straps around the fuel tank, and hook them to the holes on the on support pads (refer to Figure 6 and Figure 5 *side view*).
9. Securely tighten using the ratchet.

Note: To loosen the strap, pull the safety latch on the ratchet downward and rotate handle 180 degrees. When the strap has been fully opened, the strap may be pulled through the ratchet to take up excess slack.

10. Ascertain that the hooks stay in place while tightening with the ratchet.
11. Remove fuel tank according to the vehicle service manual.
12. Lower the transmission jack to its lowest position before transporting the fuel tank.

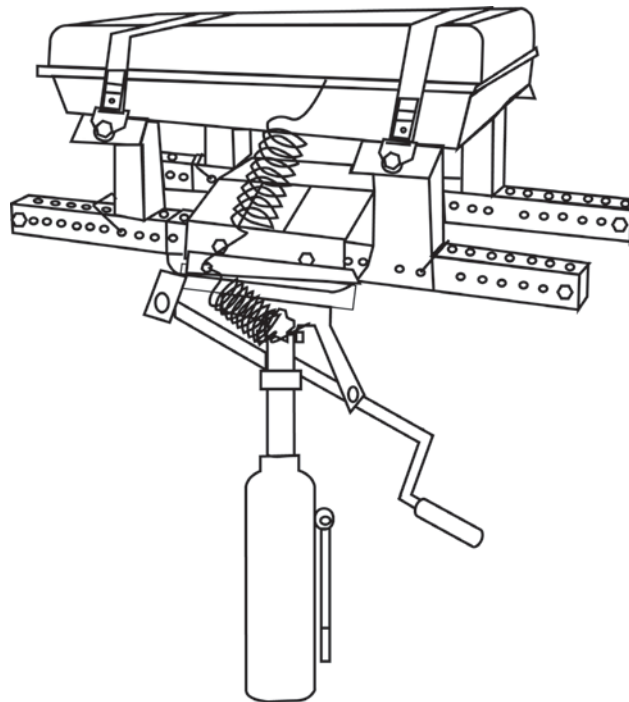

Figure 6

MAINTENANCE

Inspections should be made before each use of the Fuel Tank Adapter, checking for abnormal conditions.

1. It is important to keep the product clean.
2. Periodically wipe the product with an oily cloth.
3. Inspect the product annually.



Paint contains lead!
DO NOT sand or grind painted surface!

Storage

Store the fuel tank adapter in a clean, dry area when not in use.

TROUBLESHOOTING

Symptom	Possible Causes	Corrective Action
A vertical arm will not reposition	Bent parts	Contact Customer Service (888) 332-6419
The fuel tank does not maintain steadiness while on the adapter	Loose support pad	Contact Customer Service (888) 332-6419
The adapter is shaky or feels loose	Components are worn or loose	Check, replace, and tighten components and fasteners

ONE YEAR LIMITED WARRANTY

For a period of one (1) year from date of purchase, **ATD Tools, Inc.** will repair or replace, at its option, without charge, any of its products which fails due to a defect in material or workmanship, or which fails to conform to any implied warranty not excluded hereby.

Performance of any obligation under this warranty may be obtained by contacting your distributor or point of sale for further instructions. Please retain your proof of purchase, as it will be needed for any claim.

Except where such limitations and exclusions are specifically prohibited by applicable law, (1) the CONSUMER'S SOLE AND EXCLUSIVE REMEDY SHALL BE THE REPAIR OR REPLACEMENT OF DEFECTIVE PRODUCTS AS DESCRIBED ABOVE, and (2) **ATD Tools, Inc.** SHALL NOT BE LIABLE FOR ANY CONSEQUENTIAL OR INCIDENTAL DAMAGE OR LOSS WHATSOEVER, and (3) THE DURATION OF ANY AND ALL EXPRESSED AND IMPLIED WARRANTIES, INCLUDING WITHOUT LIMITATION, ANY WARRANTIES OF MERCHANTABILITY AND FITNESS FOR A PARTICULAR PURPOSE, IS LIMITED TO A PERIOD OF ONE (1) YEAR FROM DATE OF PURCHASE.

Some states do not allow limitations on how long an implied warranty lasts, so the above limitation may not apply to you. Some states do not allow the exclusion or limitation of incidental or consequential damages, so the above limitation or exclusion may not apply to you. This warranty gives you specific legal rights, and you may also have other rights which vary from state to state.

Replacement Parts List for ATD-7470

REPLACEMENT PARTS

Not all components of the Fuel Tank Adapter are replacement items, but are illustrated as a convenient reference of parts location. When ordering parts, give model number, part number and description below. Contact your distributor for current pricing.

Item	Part#	Description	Qty.
1	247552	Safety Snap Pin	4
2	247554	Bonding Cable Assembly	2
3	247576	Foam Pad/ Foot Assembly (1" Hole)	2
4	247578	Safety Tension Strap	2
5	247754	Foam Pad/ Foot Assembly (1/2" Hole)	2
6	247760	Hardware Kit	1
7	ATD7470-L0	Label	1
8	ATD7470-M0	Manual	1

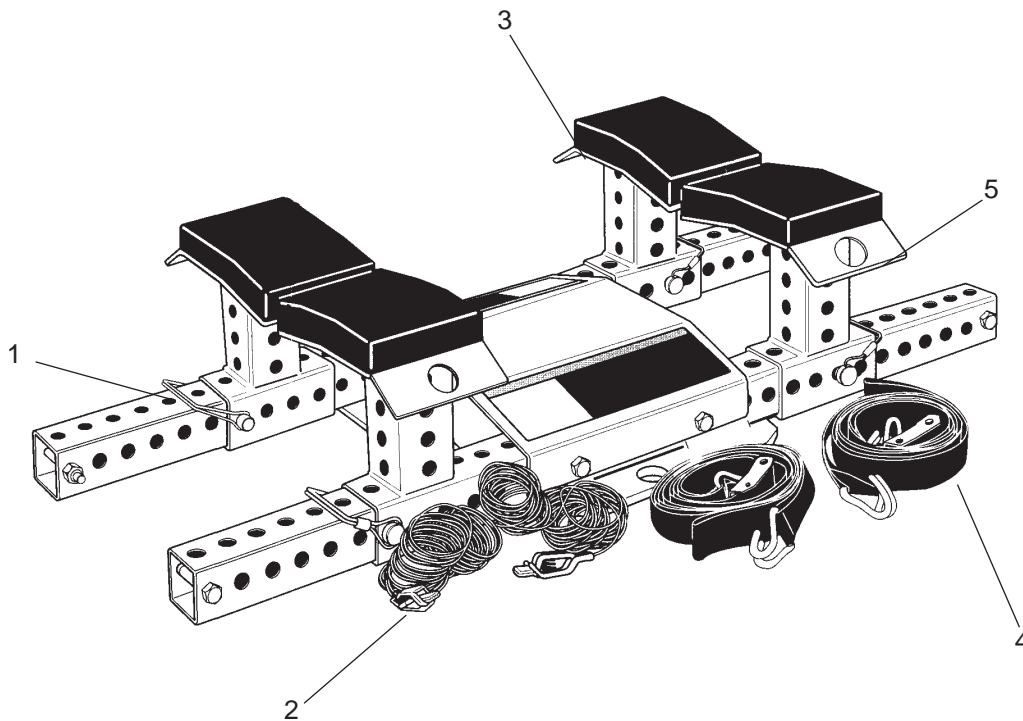

Figure 7 - Replacement Parts Illustration for ATD-7470

