



ATD-7464 OWNER'S MANUAL



Features:

- One stand can hold four (4) ATD-7465 vehicle position jacks
- Heavy duty steel construction
- Durable powder coat finish

Specifications:

- Capacity: Holds four (4) ATD-7465 vehicle position jacks
- Casters: Four (4) 3" swivel casters
- Dimensions: 30" wide x 18-1/2" deep x 9" high

 **WARNING** 

WARNING: This product may contain chemicals, including lead, known to the State of California to cause cancer, birth defects or other reproductive harm. *Wash hands after handling.*

Operation:

The owner and/or operator shall study the product instructions and retain them for future reference. The owner and/or operator shall have an understanding of the product, its operating characteristics, and safety operating instructions before operating the equipment. Safety information shall be emphasized and understood.

Safety:

Failure to heed these safety warnings may result in personal injury and/or property damage.



WARNING: Study, understand and follow all instructions before operating this device.



WARNING: This unit is designed for ATD-7465 vehicle positioning jacks only.



WARNING: DO NOT overload unit beyond the load rating of 4 pieces of ATD-7465 -175 lbs (80 Kgs)



WARNING: DO NOT operate unit on inclined surfaces. Unit must be used on level surface only.



WARNING: DO NOT attempt to push jack rack over obstacles. They are designed to be used on level surfaces only.



WARNING: No alterations shall be made to this product.

Damaged Equipment:

Any equipment that appears to be damaged in any way or is found to be worn or operating abnormally **SHALL BE REMOVED FROM SERVICE UNTIL REPAIRED**. It is recommended that necessary repairs be made by a specialized repair facility.

Inspection:

- Visual inspection shall be made before each use of the equipment by checking for abnormal conditions, such as cracked welds, damaged, or missing parts.
- Each piece of equipment shall be inspected immediately if the device is believed to have been subjected to an abnormal load or shock. It is recommended that this inspection be made by a specialized repair facility.
- Owners and/or operator should be aware that repair of this equipment may require specialized knowledge.

Assembly Instructions:

1. Assemble Left/Right Frame to Jack Rack by using 2 hex head screws and washers. Tighten all fasteners.
2. Install casters to Left/Right Frame. Tighten all screws and nuts, taking care not to over-tighten.



ATD-7464

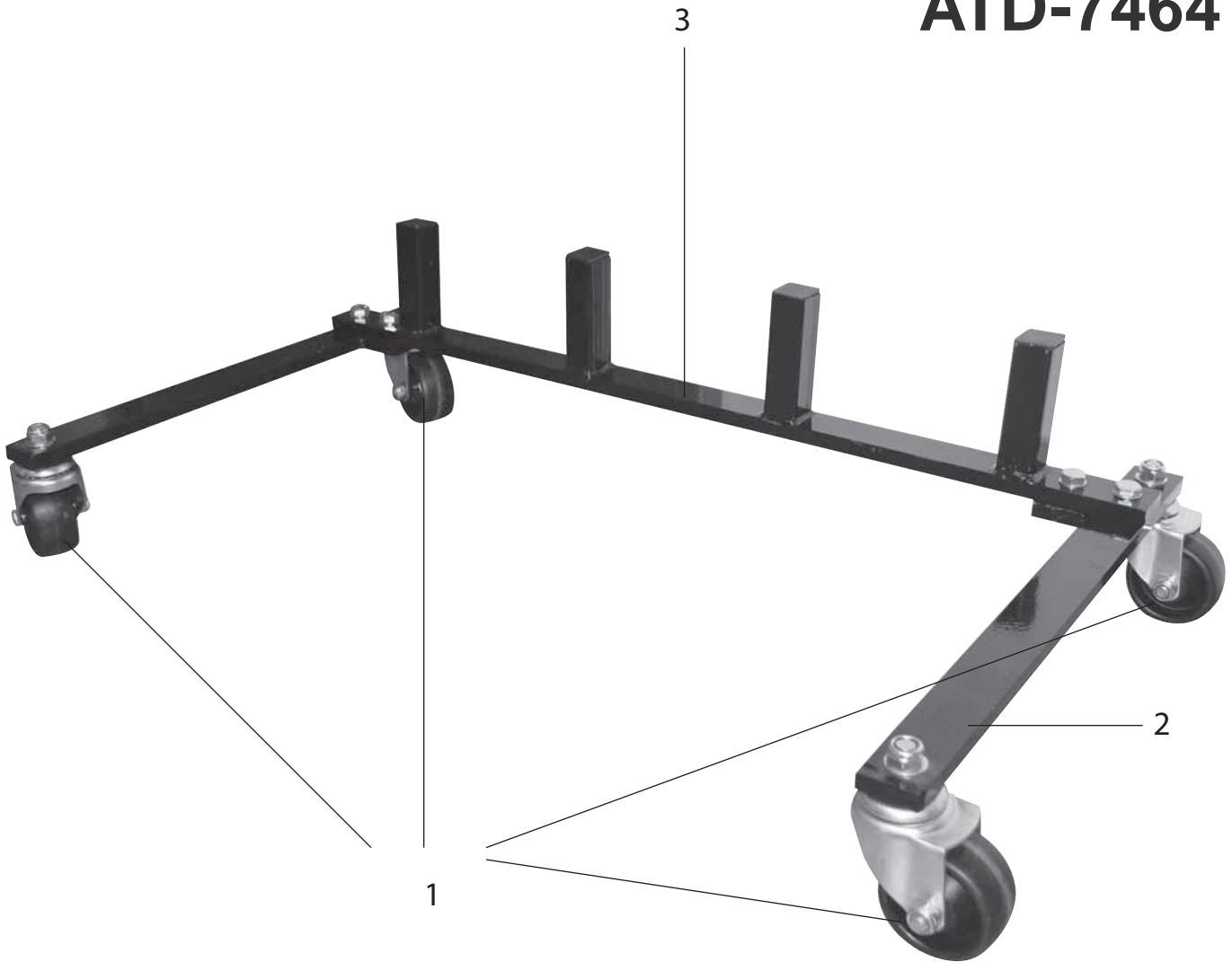

ITEM#	ORDERING PART#	PART DESCRIPTION
1	PRT7464-01	CASTERS
2	PRT7464-02	FRAME
3	PRT7464-03	JACK RACK
N/S	PRT7464-04	FRAME HARDWARE PACKAGE



WARRANTY

1 YEAR LIMITED WARRANTY

THIS WARRANTY AND CONFIRMED RECEIPT(S) SHOULD BE RETAINED BY THE CUSTOMER AT ALL TIMES

PURCHASED FROM: _____

DATE PURCHASED: _____

INVOICE/RECIPT NUMBER: _____

Your ATD-7464 is warranted for a period of 12 months from the original purchase date.

For a period of one (1) year from your purchase date, ATD Tools Inc. will repair or replace (at its option) without charge, your ATD product if it was purchased new and the product has failed due to a defect in material or workmanship which you experienced during normal use of the product. This limited warranty is your exclusive remedy.

To access the benefits of this warranty, contact your supplier, or point of sale directly. You may be advised to return the product under warranty, freight prepaid, to your supplier for warranty determination.

If this ATD product is altered, abused, misused, modified, or undergoes service by an unauthorized technician, your warranty will be void. We are not responsible for damage to ornamental designs you place on this ATD product and such ornamentation should not cover any warnings or instructions or they may void the warranty. This warranty does not cover scratches, superficial dents, and other abrasions to the paint finish that occur under normal use. It also does not cover normal wear items such as but not limited to brushes, batteries, drill bits, drill chucks, pads or blades.

Subject to the law in your state:

- (1) Your sole and exclusive remedy is repair or replacement of the defective product as described above.
- (2) ATD is not liable for any incidental damages, including but not limited to, lost profits and unforeseeable consequences.
- (3) The repair and replacement of this product under the express limited warranty described above is your exclusive remedy and is provided in lieu of all other warranties, express or implied. All other warranties, including implied warranties and warranties of merchantability or fitness for a particular purpose are disclaimed and, if disclaimer is prohibited, these warranties are limited to one year from your date of purchase of this product.

Some states' laws do not allow limited durations on certain implied warranties and some states' laws do not allow limitations on incidental or consequential damages. You should consult the law in your state to determine how your rights may vary.

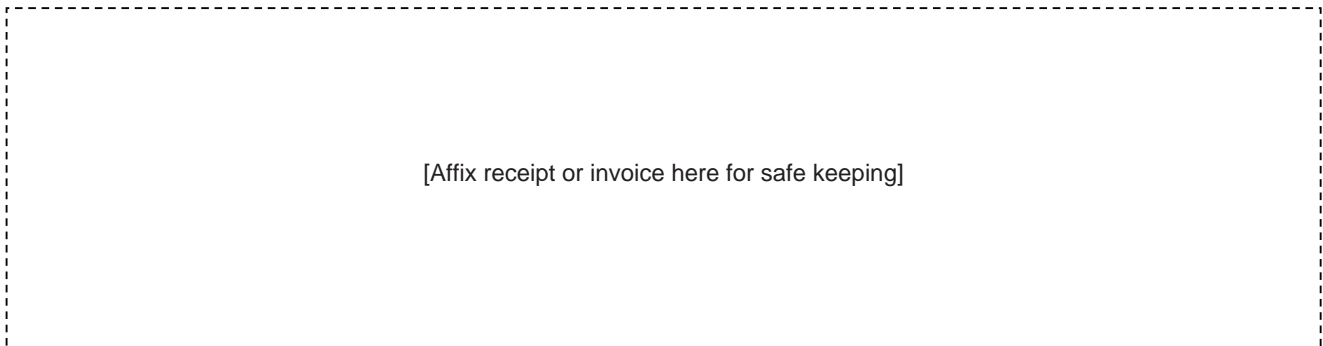

[Affix receipt or invoice here for safe keeping]