



ATD-7434A

1-Ton Air Actuated Telescopic Transmission Jack Owner's Manual



Features:

- Extra-wide base lowers center of gravity and promotes stability
- Rugged steel wheels and full swivel ball bearing casters
- A unique, foot release pedal provides controlled lowering of load
- Adjustable saddle for quick adjustment for most pan configurations
- Chrome-plated rams maximize it's high reach
- A compact, yet powerful air motor is equipped to raise the load to the desired height efficiently, effortlessly and safely
- Load control chain secures transmission to jack
- Meets or exceeds ASME/PASE 2014 standards

Specifications:

- Capacity (Ton): 1
- Minimum Height: 35.24"
- Maximum Height: 71.65"
- Saddle Base: 10.24" x 10.83"
- Expanded Saddle Area Max.: 14.17" x 10.83"
- Shipping Weight: 210 lbs.

SAVE THESE INSTRUCTIONS:

For your safety, read, understand, and follow the information provided with and on this jack. The owner and operator of this equipment should have an understanding of this jack and safe operating procedures before attempting to use. The owner and operator should be aware that use and repair of this product may require special skills and knowledge. Instructions and safety information should be conveyed in the operator's native language before use of this jack is authorized. If any doubt exists as to the safe and proper use of this jack, remove from service immediately. Inspect before each use. Do not use if broken, bent, cracked or damaged parts are noted. Any jack that appears damaged in any way, or operates abnormally should be removed from service immediately. If the jack has been or suspected to have been subjected to a shock load (a load dropped suddenly, unexpectedly upon it), immediately discontinue use until jack has been checked by a Factory Authorized Service Center. It is recommended that an annual inspection be done by qualified personnel. Labels and owner's manuals are available from manufacturer.

PRODUCT DESCRIPTION:

ATD Tools hydraulic transmission jacks are designed to be used as an aid in the removal and installation of automotive and light truck transmissions, transfer cases and transaxles. They are intended for use under an overhead lift or in a garage pit. This jack meets or exceeds ASME-PALD standards. Ensure the air source can dedicate 7.8 CFM @ 90-175 psi. To ensure dependable, trouble free operation an inline air dryer and oiler is recommended.

SPECIFICATIONS:

Model	Capacity	Min. Height	Max. Height	Saddle Base	Max. Saddle Area	Weight
ATD-7434A	2,000 lbs.	35.24"	71.65"	10.24" x 10.83"	14.17" x 10.83"	210 lbs.

CAUTION: READ CAREFULLY BEFORE UNPACKING PRODUCT.

! WARNING

- Study, understand, and follow all printed materials provided with/on this product before use.
- Do not exceed rated capacity.
- Use only on hard, level surfaces capable of supporting rated capacity loads.
- Use of this jack is limited to the removal, installation and transportation of transmissions, transfer cases and transaxles. Do not use a transmission jack to tilt or support a vehicle.
- Ensure the center gravity of load is centered on the saddle.
- Do not exceed 10° tilt angle of the saddle assembly in all directions.
- Adequately support the vehicle before starting repairs
- Use only chains and slings provided.
- If loaded jack must be moved, make sure that the load is secured, stable and in lowest position.
- This is a lifting and lowering device only.
- Transfer load immediately to appropriate support device for service or repair.
- No alterations shall be made to this product
- Failure to heed these markings may result in personal injury and/or property damage.

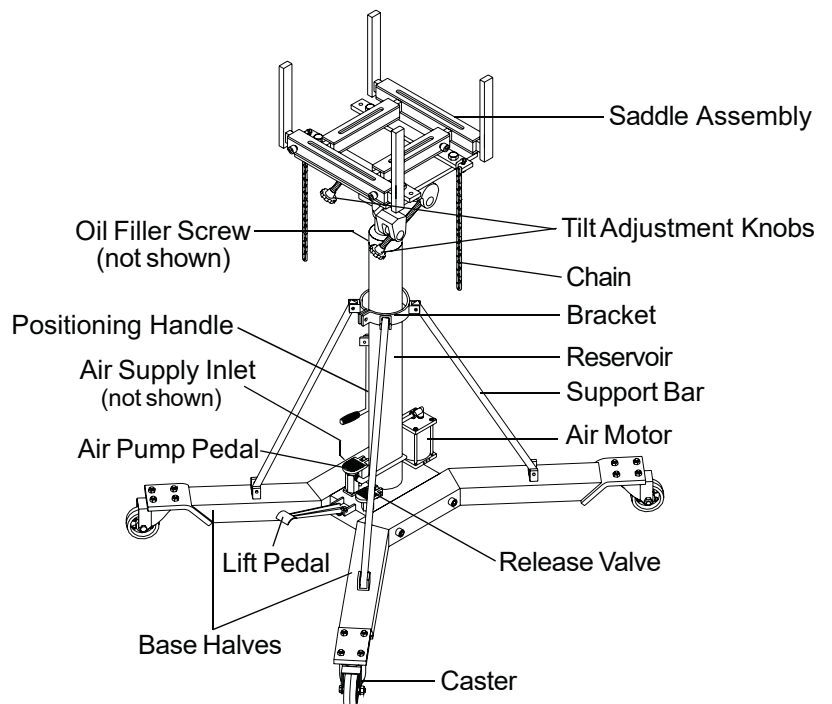

Figure 1 - Model ATD-7434A nomenclature

Note: Vent Screw and Oil Filler Screw are located on the upper portion of the reservoir.

ASSEMBLY

Refer to Figure 1 & 2:

1. Three major parts should be included in package:
 - (a) Hydraulic unit with pumping mechanism (with air motor equipped)
 - (b) Saddle assembly
 - (c) 2 pieces of base half with bolts and washers
2. Attach one of the base halves to the base of the hydraulic unit, then secure using bolts and washers provided. Then apply the same procedure to the other base half. Do not tighten until step 4.
3. Assemble swivel casters to the leg caster brackets
4. Now tighten the bolts from the base halves to the hydraulic unit. Use torque wrench to tighten to 30 ft.-lbs.
5. Install the saddle assembly onto the cylinder arm.
6. The hydraulic power unit is equipped with two reservoir fill screws. The closed filler screw is installed in the reservoir at the factory so the jack will not leak during shipment.

BEFORE USE:

1. Inspect jack before each use. Do not use if bent, broken or cracked components are noted. Ensure that casters move freely. Check for and tighten any loose assemblies.
2. Verify that the product and the application are compatible.
3. With ram fully lowered, remove oil filler screw to bleed air in the reservoir.
4. Ensure oil level is just below the rim of the oil filler screw hole. Reinstall the oil filler screw.
5. Pour a teaspoon of good quality air tool lubricant into the air supply inlet (See Figure 2). Connect to air supply and operate for 3 seconds to evenly distribute lubricant.
6. Your ATD-7434A is fitted to accept the popular 1/4" NPT air nipple. When installing air nipple, ensure thread sealing compound is used on connections. Be careful not to allow compound to enter the air supply inlet orifice. Application of thread tape is acceptable, but ensure that it is not applied beyond the first machine thread.

Raise Saddle:

Caution! Do not operate your ATD-7434A jack by pumping the lift pedal and pressing the air pump pedal at the same time.

1. Pump foot pedal or press air pump pedal until the saddle reaches the desired position.
2. Follow vehicle manufacturer's recommended procedures for removing the load as outlined in vehicle service manual or repair guide.
3. Secure load with provided chains.
4. Ensure load's center of gravity is centered on the saddle and load is stable before moving jack.

Lower Saddle:

Caution! Be sure all tools and personnel are clear before lowering load.

Slowly, gently apply downward pressure to the release valve pedal.

OPERATION:

When disassembling the transmission, position the transmission jack under the transmission. Depress the foot pedal to raise the saddle to a height close to the center of the balance point of the transmission oil pan but do not touch the transmission.

Adjust the ratchet arms on the saddle so that the angled section of the arms will fit in the mounting flange around the perimeter of the transmission oil pan. Slowly pump the jack to raise the saddle to fully connect the transmission. Secure the transmission to the jack's saddle with the safety chains provided. If necessary, turn the fore and aft and side to side tilt knobs so the saddle is in the proper alignment with the transmission pan before securing the load to the saddle.

IMPORTANT:

Make sure the tie down strap is very tight when securing the transmission to the saddle and before raising or lowering the transmission. Remove the transmission from the engine according to the instructions in the vehicle service manual. Once the transmission has been disassembled from the engine, very slowly depress the release pedal to lower the transmission all the way down.

IMPORTANT:

Be sure all tools and personnel are clear before lowering load. Slowly depress release valve pedal. When installing a transmission, refer to the above instructions and the vehicle manufacturer's installation manual.

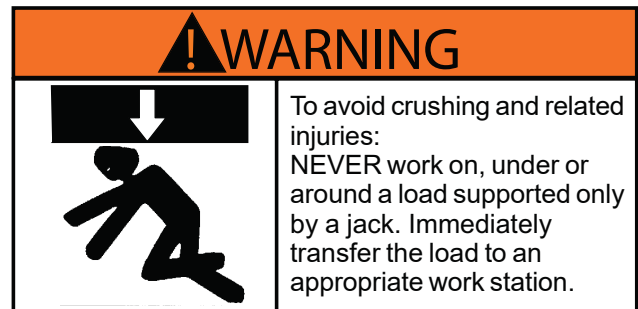

MAINTENANCE

Important: Use only good grade hydraulic jack oil. Avoid mixing different types of fluid and NEVER use brake fluid, turbine oil, transmission fluid, motor oil or glycerin. Improper fluid can cause premature failure of the jack and the potential for sudden and immediate loss of load. We recommend Mobil DTE 13M or equivalent.

Periodically check for leaks at air connections. Replace connections as needed.

Adding oil:

1. With saddle fully lowered, set jack in its upright, level position. Remove oil filler screw.
2. Fill until oil is level with the filler hole screw, reinstall oil filler screw.

Changing oil:

For best performance and longest life, replace the complete fluid supply at least once per year.

1. With saddle fully lowered, set jack in its upright, level position. Remove the oil filler screw.
2. Lay the jack on its side and drain the fluid into a suitable container.

Note: Dispose of hydraulic fluid in accordance with local regulations.

3. Set jack in its level, upright position and fill with oil until just below the rim of the filler hole.
4. Reinstall the oil filler screw.

Lubrication:

1. A periodic coating of light lubricating oil to pivot points, axles and hinges will help to prevent rust and assure that wheels, casters and pump assemblies move freely.
2. When used on a daily basis, the ATD-7434A should be internally lubricated before each use. Use only good quality air tool lubricant. If no inline oiler is used, pour a teaspoon of air tool oil into the inlet of the air supply inlet. Simply operate the jack using the air feature in order to fully distribute the oil.

Cleaning:

Periodically check the ram for signs of rust or corrosion. Clean as needed and wipe with an oily cloth.

Note: Never use sandpaper or abrasive material on these surfaces

Purging air from the hydraulic system:

Air can accumulate within a hydraulic system during shipment or after prolonged use. This entrapped air causes the jack to respond slowly or feel "spongy." Use the steps below to bleed the system.

1. Pump the jack to the highest point where the first and the second piston rams are both at maximum height.
2. Get the help of another person to keep the release pedal depressed, and activate the foot pedal about 20 times.
3. Let go of the release pedal; the air in the oil system should be bled successfully.

To bleed the air in the second cylinder:

1. Locate the air bleeder screw at the top nut, which is on the top of the first piston rod.
2. Pump the jack to its maximum height. Use an allen socket wrench to loosen the air bleeder screw for no more than two 360° turns. Push the saddle assembly downward to force the air in the cylinder out until nothing but oil drains out of the bleeder hole.
3. Tighten the bleeder screw and double check. It may be necessary to repeat the above steps several times.

Storage:

When not in use, store the jack with saddle in lowest position and air supply disconnected.

TROUBLESHOOTING

Symptom	Possible Causes	Corrective Action
Jack will not lift load	<ul style="list-style-type: none"> • Air supply inadequate • Hydraulic unit malfunction 	<ul style="list-style-type: none"> • Ensure adequate air supply • Contact Tech. Service (636) 327-9050
Jack bleeds off after lift	<ul style="list-style-type: none"> • Overload condition • Hydraulic unit malfunction 	<ul style="list-style-type: none"> • Remedy overload condition • Contact Tech. Service (636) 327-9050
Jack will not lower after unloading	<ul style="list-style-type: none"> • Reservoir overfilled • Linkage binding 	<ul style="list-style-type: none"> • Drain fluid to proper level • Clean and lubricate moving parts
Poor lift performance	<ul style="list-style-type: none"> • Fluid level low 	<ul style="list-style-type: none"> • Ensure proper fluid level
Will not lift to full extension	<ul style="list-style-type: none"> • Fluid level low 	<ul style="list-style-type: none"> • Ensure proper fluid level

REPLACEMENT PARTS

Not all components of the jack are replacement items, but are illustrated as a convenient reference for position in the assembly sequence. When ordering parts, give model number, part number and description. Call your distributor for current pricing:

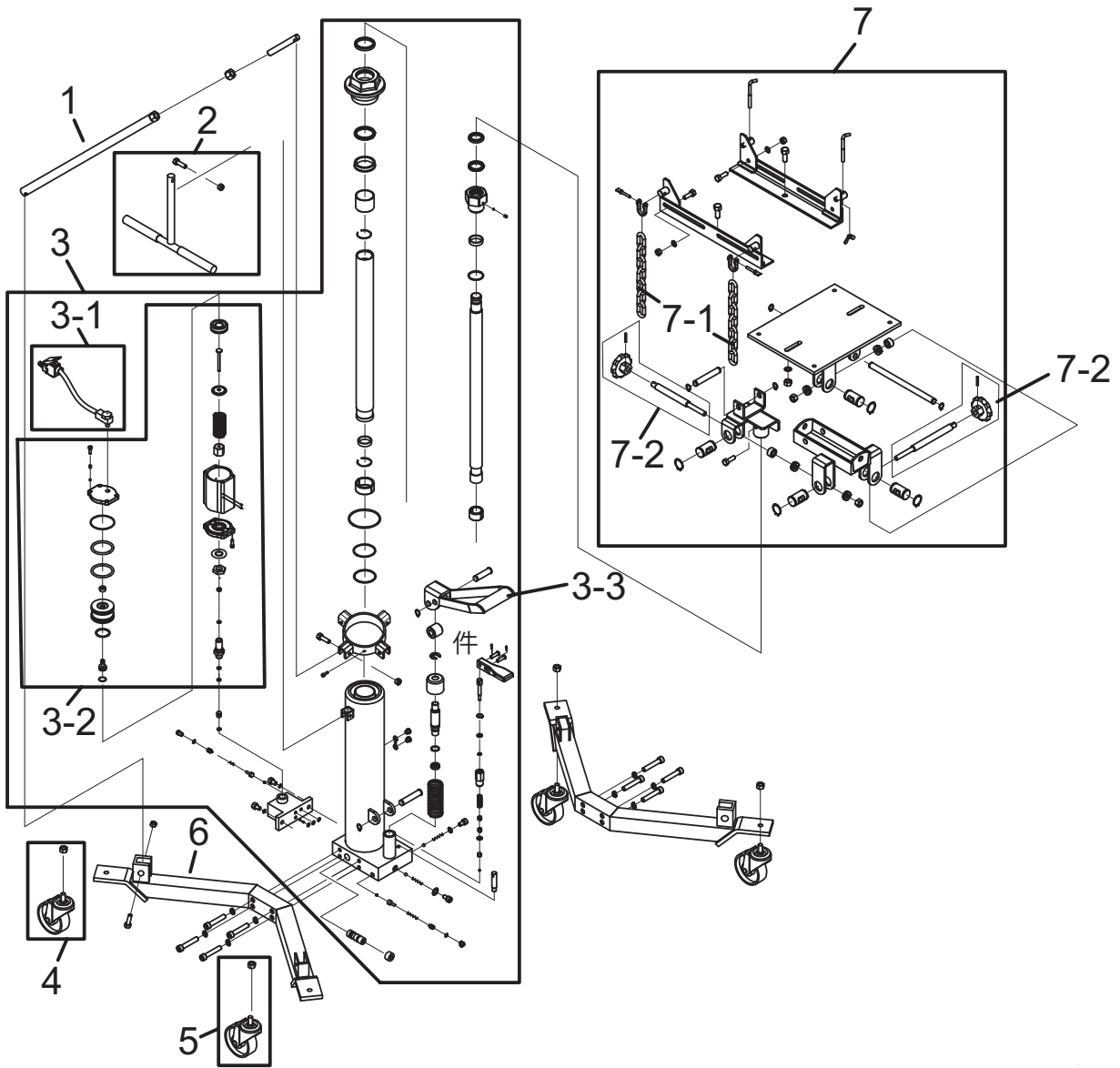

ITEM#	ORDERING PART#	PART DESCRIPTION	QTY
1	PRT7434A-01	SUPPORTING ROD	1
2	PRT7434A-02	HANDLE ASSEMBLY	1
3	PRT7434A-03	HYDRAULIC ASSEMBLY	1
3-1	PRT7434A-03-1	AIR HOSE ASSEMBLY	1
3-2	PRT7434A-03-2	AIR MOTOR ASSEMBLY	1
3-3	PRT7434A-03-3	FOOT PEDAL	1
4	PRT7434A-04	CASTER	2
5	PRT7434A-05	LOCKING CASTER	2
6	PRT7434A-06	LEG WELDMENT	2
7	PRT7434A-07	SADDLE ASSEMBLY	1
7-1	PRT7434-07-1	CHAINS (SET OF 2)	2
7-2	PRT7434A-09	SADDLE ADJUSTMENT SCREWS (SET OF 2)	2
N/S	PRT7434A-SK	AIR MOTOR AND HYDRAULIC UNIT SEAL KIT	1

Figure 4 - Replacement Parts Illustration for model ATD-7434A



THIS WARRANTY AND CONFIRMED RECEIPT(S) SHOULD BE RETAINED BY THE CUSTOMER AT ALL TIMES

PURCHASED FROM: _____

DATE PURCHASED: _____

INVOICE/RECEIPT NUMBER: _____

Your ATD-7434A is warranted for a period of 12 months from the original purchase date.

For a period of one (1) year from your purchase date, ATD Tools, Inc. will repair or replace (at its option) without charge, your ATD product if it was purchased new and the product has failed due to a defect in material or workmanship which you experienced during normal use of the product. This limited warranty is your exclusive remedy.

To access the benefits of this warranty, contact your supplier, or point of sale directly. You may be advised to return the product under warranty, freight prepaid, to your supplier for warranty determination.

If this ATD product is altered, abused, misused, modified, or undergoes service by an unauthorized technician, your warranty will be void. We are not responsible for damage to ornamental designs you place on this ATD product and such ornamentation should not cover any warnings or instructions or they may void the warranty. This warranty does not cover scratches, superficial dents, and other abrasions to the paint finish that occur under normal use. It also does not cover normal wear items such as but not limited to brushes, batteries, drill bits, drill chucks, pads or blades.

Subject to the law in your state:

- (1) Your sole and exclusive remedy is repair or replacement of the defective product as described above.
- (2) ATD is not liable for any incidental damages, including but not limited to, lost profits and unforeseeable consequences.
- (3) The repair and replacement of this product under the express limited warranty described above is your exclusive remedy and is provided in lieu of all other warranties, express or implied. All other warranties, including implied warranties and warranties of merchantability or fitness for a particular purpose are disclaimed and, if disclaimer is prohibited, these warranties are limited to one year from your date of purchase of this product.

Some states' laws do not allow limited durations on certain implied warranties and some states' laws do not allow limitations on incidental or consequential damages. You should consult the law in your state to determine how your rights may vary.

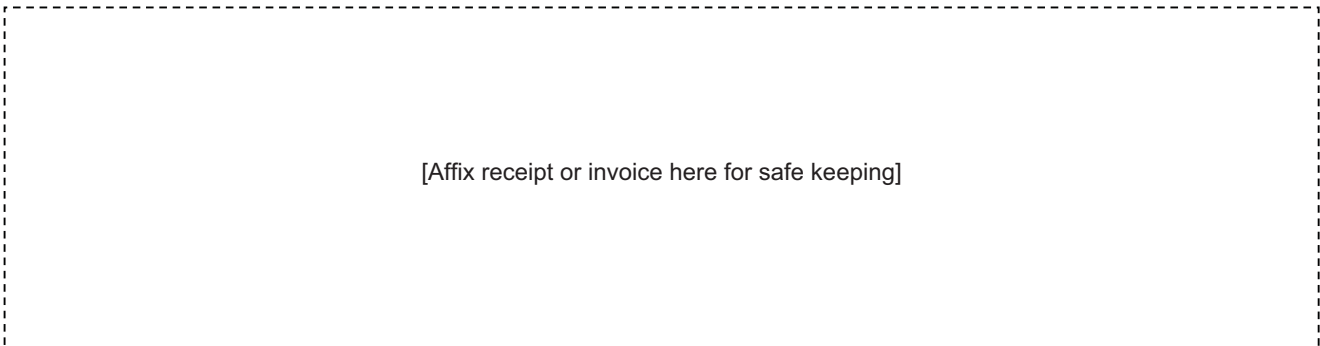

[Affix receipt or invoice here for safe keeping]