



# Swift Lift Hydraulic Service Jack

## Operating Instructions & Parts Manual

**Model Number**  
**ATD-7341**

**Capacity**  
**3-1/2 Ton**

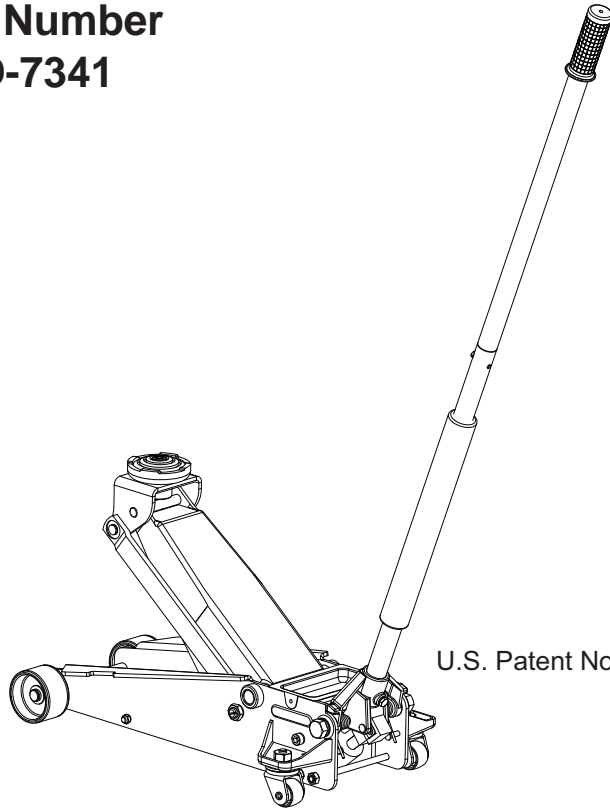

U.S. Patent No's. 5,946,912 • 6,199,379



This is the safety alert symbol. It is used to alert you to potential personal injury hazards. Obey all safety messages that follow this symbol to avoid possible injury or death.

<b>⚠ WARNING</b>	
To avoid <b>crushing and related injuries</b> :	
	<b>NEVER</b> work on, under or around a load supported only by a hydraulic jack. <b>ALWAYS</b> use a pair of adequately rated jack stands.

<b>⚠ WARNING ⚠</b>	
<small><b>WARNING:</b> This product contains chemicals, including lead, known to the State of California to cause cancer, birth defects or other reproductive harm. <i>Wash hands after handling.</i></small>	

Made in China to ATD Tools, Inc. Specifications  
Visit us at [www.atdtools.com](http://www.atdtools.com)

**Read this manual and follow all the Safety Rules and Operating Instructions before using this product.**

## SAFETY AND GENERAL INFORMATION

**Save these instructions.** For your safety, read, understand, and follow the information provided with and on this device before using. The owner and/or operator shall have an understanding of the device, its operating characteristics and safety operating instructions before operating the equipment. The owner and/or operator shall be aware that use and repair of this product may require special skills and knowledge. Instructions and safety information shall be read to and discussed with the operator in the operator's native language, making sure that the operator comprehends their contents, before use of this equipment is authorized. If any doubt exists as to the safe and proper use of this device, remove from service immediately.

**Inspect before each use.** Do not use if abnormal conditions such as cracked welds, damaged, loose or missing parts are noted. Any equipment that appears damaged in any way, is found to be worn, or operates abnormally shall be removed from service until repaired. If the equipment has been or is suspected to have been subjected to an abnormal load or shock, immediately discontinue use until inspected by a factory authorized repair facility (contact distributor or manufacturer for list of authorized repair facilities). It is recommended that an annual inspection be made by an authorized repair facility. Labels and Operator's Manuals are available from the manufacturer.

## PRODUCT DESCRIPTION

This Hydraulic Service Jack is designed to lift, but not support, one end of a vehicle. Immediately after lifting, loads must be supported by a pair of appropriately rated jack stands. This Swift Lift™ service jack has a unique feature that provides fast, no load lifts to the jacking point, at which time it lifts in approximately 1/4"~3/4" increments.



**Never** use a hydraulic jack as a stand alone support device. After lifting, immediately support the lifted vehicle with appropriately rated jack stands. Never place any portion of your body under the vehicle when lifting or lowering.

## PREPARATION

### Assembly

Insert handle into the handle fork. Tighten the bolt on handle fork to prevent accidental removal of handle while in use.

### Before Use

1. Verify that the product and application are compatible.
2. Before using this product, read the operator's manual completely and familiarize yourself thoroughly with the product, its components and recognize the hazards associated with its use.
3. To familiarize yourself with basic operation, locate and turn the release valve (handle):
  - a. Clockwise until firm resistance is felt to further turning. This is the '**CLOSED**' release valve position used to **raise** the saddle.
  - b. Counter-clockwise, but no more than 1/2 turn from the closed position. This is the '**OPEN**' release valve position used to **lower** the saddle.
4. With ram plunger fully retracted and release valve closed, pump the operating handle. If ram plunger responds immediately, jack is ready for use. If jack does not respond, follow Bleeding/Venting Trapped Air instruction below.
5. Ensure that jack rolls freely. Raise and lower the unloaded saddle throughout the lifting range before putting into service to ensure the pump operates smoothly. Replace worn or damaged parts and assemblies with authorized replacement parts only.

### Bleeding/Venting Trapped Air

With the release valve in the OPEN position (step 3b. above) and with saddle fully lowered, locate and remove the cover plate, then remove the oil filler plug. Insert handle into handle fork and pump 6 to 8 full strokes. This will help release pressurized air which may be trapped within the reservoir. Reinstall the oil filler plug and check operation.

## SPECIFICATIONS

Model	Capacity	Jack Size (L x W x H)	Min. Height	Max. Height	Saddle Dia.
ATD-7341	3-1/2 Ton	28-1/2" x 13-3/4" x 6-1/2"	5-1/2"	22"	4"

## OPERATION

### Lifting



Only attachments and/or adapters supplied by the manufacturer shall be used. Lift only on area of the vehicle as specified by the vehicle manufacturer.

1. Follow the vehicle manufacturer's recommended guidelines for lifting. Engage the emergency brake and chock each unlifted wheel in both directions to prevent inadvertent vehicle movement.
2. Close the release valve by turning the handle clockwise until firm resistance is felt.
3. Refer to the vehicle manufacturer owner's manual to locate approved lifting points on the vehicle. Center jack saddle under lift point.
4. Verify lift point, pump handle to contact lift point. To lift, pump handle until load reaches desired height.
5. Transfer the load **immediately** to appropriately rated jack stands.



**NEVER** use hydraulic jack as a stand alone device! **ALWAYS** transfer the lifted load **IMMEDIATELY** to a pair of appropriately rated jack stands. Use one pair of jack stands per vehicle. Rated capacity is per pair only! Do not exceed rated capacity.

### Lowering



Be sure all tools and personnel are clear before lowering load. **Slowly open the release valve!** The more you turn the handle counter-clockwise, the faster the load will come down. **Maintain control** of the rate of speed at which the load lowers at all times!

1. Raise load high enough to clear the jack stands.
2. Remove jack stands carefully.
3. **Slowly** turn the handle counter-clockwise, but no more than 1/2 full turn. If the load fails to lower:
  - a. Use another jack to raise the vehicle high enough to reinstall jack stands.
  - b. Remove the malfunctioning jack and then the jack stands.
  - c. Use the functioning jack to lower the vehicle.
4. After removing jack from under the vehicle, fully lower the saddle to reduce ram exposure to rust and contamination.

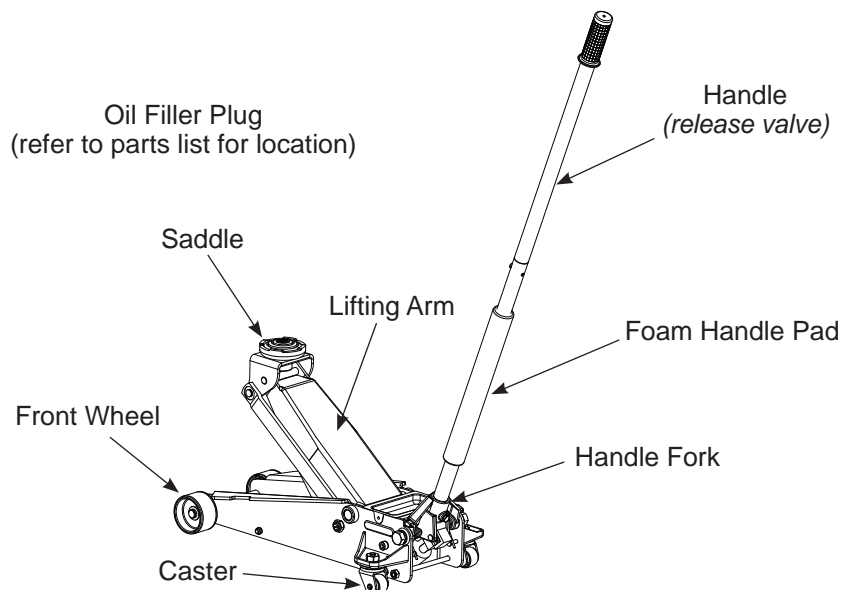

Figure 1 - Typical Jack Nomenclature

**⚠ WARNING**

- Study, understand, and follow all instructions before operating this device.
- Do not exceed rated capacity.
- Use only on hard, level surface.
- This is a lifting device only. Immediately after lifting, support the load with appropriate means.
- Lift only on areas of the vehicle as specified by the vehicle manufacturer.
- No alterations shall be made to this product.
- Only attachments and/or adapters supplied by the manufacturer shall be used.
- Failure to heed these markings may result in personal injury and/or property damage.

**⚠ WARNING**



To avoid crushing and related injuries:

- Never work on, under or around a load supported only by hydraulic jack.
- Chock unlifted tires in both directions.
- Do not use this device to lift, level, lower, support nor move a house, mobile home, travel trailer, camper or any building structure.
- Be alert and sober when using this product. Do not operate under the influence of drugs or alcohol.

## MAINTENANCE

**NOTE:** Use only good grade hydraulic jack oil. Avoid mixing different types of fluid and NEVER use brake fluid, turbine oil, transmission fluid, motor oil or glycerin. Improper fluid can cause premature failure of the jack and the potential for sudden and immediate loss of load. We recommend premium hydraulic jack oil.

### Adding oil

1. With saddle fully lowered set jack in its upright, level position. Remove oil filler plug.
2. Fill with oil until ~3/16" above the inner cylinder as seen from the oil filler hole. Reinstall oil filler plug.

### Changing oil

For best performance and longest life, replace the complete fluid supply at least once per year.

1. With saddle fully lowered, remove oil filler plug.
2. Lay the jack on its side and drain the fluid into a suitable container.

**Note.** Dispose of hydraulic fluid in accordance with local regulations.

3. Fill with oil until ~3/16" above the inner cylinder as seen from the oil filler hole. Reinstall oil filler plug.

### Lubrication

A periodic coating of light lubricating oil to pivot points, axles and hinges will help to prevent rust and assure that wheels, casters and pump assemblies move freely.

### Cleaning

Periodically check the pump piston and ram for signs of rust or corrosion. Clean as needed and wipe with an oily cloth.

**Note:** Never use sandpaper or abrasive material on these surfaces!

### Storage

When not in use, store the jack with saddle fully lowered.

## TROUBLESHOOTING

Symptom	Possible Causes	Corrective Action
Jack will not lift load	<ul style="list-style-type: none"><li>• Release valve not tightly closed</li><li>• Load is too heavy</li></ul>	<ul style="list-style-type: none"><li>• Ensure release valve tightly closed</li><li>• Consider higher capacity jack</li></ul>
Jack will lift, but not maintain pressure	<ul style="list-style-type: none"><li>• Release valve not tightly closed</li><li>• Hydraulic unit malfunction</li></ul>	<ul style="list-style-type: none"><li>• Ensure release valve tightly closed</li><li>• Discontinue use, contact Technical Service</li></ul>
Jack will not lower after unloading	<ul style="list-style-type: none"><li>• Reservoir overfilled</li><li>• Linkages binding</li><li>• Fluid level low</li></ul>	<ul style="list-style-type: none"><li>• Drain fluid to proper level</li><li>• Clean and lubricate moving parts</li><li>• Ensure proper fluid level</li></ul>
Poor lift performance	<ul style="list-style-type: none"><li>• Fluid level low</li><li>• Hydraulic unit malfunction</li></ul>	<ul style="list-style-type: none"><li>• Ensure proper fluid level</li><li>• Discontinue use, contact Technical Service</li></ul>
Will not lift to full extension	<ul style="list-style-type: none"><li>• Fluid level low</li></ul>	<ul style="list-style-type: none"><li>• Ensure proper fluid level</li></ul>

## REPLACEMENT PARTS

Not all components of the jack are replacement items, but are illustrated as a convenient reference of location and position in the assembly sequence. When ordering parts, give Model number, serial number and parts description. Call your distributor for current pricing.

**Replacement Parts for model ATD-7341:**

Item	Part No.	Description	Qty
1	G73500-0002	Hydraulic Power Unit	1
2	G73500-0018	Front Wheel Assembly	2
3	G72500-0003	Rear Caster Assembly	2
4	G49300-0006	Saddle	1
5	G73800-0008	Saddle Pad	1
6	F36100-0001	Oil Filler Plug	1
7	G73500-0007	U-joint Assembly	1
8	G73500-0026	Handle Assembly	1
9	G61801-1007	Foam Handle Pad	1
10	G48900-0024	Handle Retaining Bolt, M10	1
11	G73500-0010	Return Spring (Right), Handle Fork	1
12	G73500-0016	Return Spring (Left), Handle Fork	1
13	G49300-0002	Return Spring, Lift Arm	1
14	G73700-0002	Tool Tray	1
15	G73500-0005	Pump Piston	1
16	G73500-0021	Handle Fork	1
-	G73504-0000	Repair Kit	-

\*\* Replacement requires special skills, knowledge, and equipment. Only authorized service center may perform the repair and/or replacement of these items.

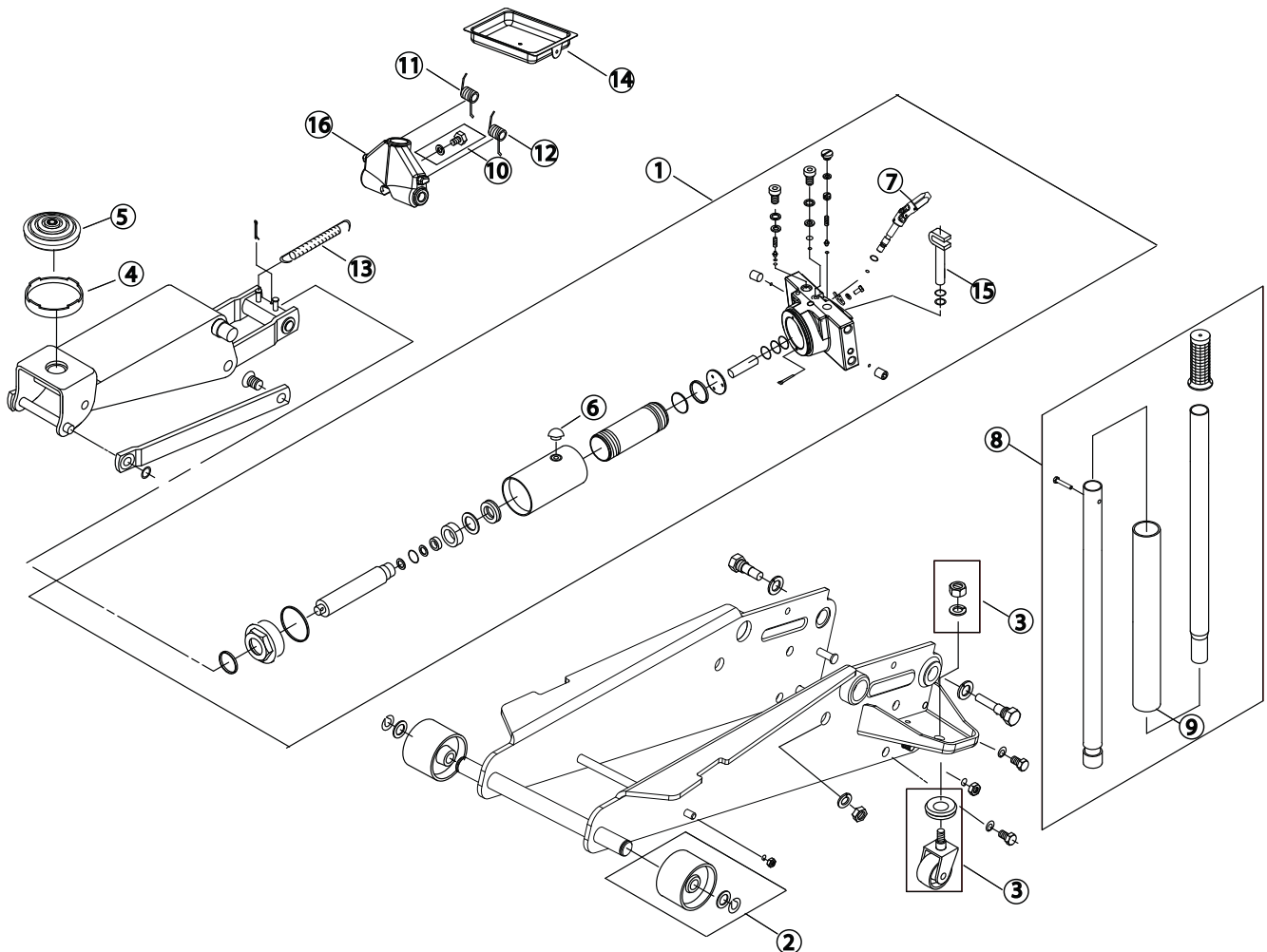

Figure 2 - Replacement Parts Illustration for model ATD-7341

## ONE YEAR LIMITED WARRANTY

For a period of one (1) year from date of purchase, **ATD Tools, Inc.** will repair or replace, at its option, without charge, any of its products which fails due to a defect in material or workmanship under normal usage. This limited warranty is a consumer's exclusive remedy.

Performance of any obligation under this warranty may be obtained by contacting your distributor or point of sale for further instructions.

Except where such limitations and exclusions are specifically prohibited by applicable law, (1) THE CONSUMER'S SOLE AND EXCLUSIVE REMEDY SHALL BE THE REPAIR OR REPLACEMENT OF DEFECTIVE PRODUCTS AS DESCRIBED ABOVE. (2) **ATD Tools, Inc.** SHALL NOT BE LIABLE FOR ANY CONSEQUENTIAL OR INCIDENTAL DAMAGE OR LOSS WHATSOEVER. (3) ANY IMPLIED WARRANTIES, INCLUDING WITHOUT LIMITATION THE IMPLIED WARRANTIES OF MERCHANTABILITY AND FITNESS FOR A PARTICULAR PURPOSE, SHALL BE LIMITED TO ONE YEAR, OTHERWISE THE REPAIR, REPLACEMENT OR REFUND AS PROVIDED UNDER THIS EXPRESS LIMITED WARRANTY IS THE EXCLUSIVE REMEDY OF THE CONSUMER, AND IS PROVIDED IN LIEU OF ALL OTHER WARRANTIES, EXPRESS OR IMPLIED. (4) ANY MODIFICATION, ALTERATION, ABUSE, UNAUTHORIZED SERVICE OR ORNAMENTAL DESIGN VOIDS THIS WARRANTY AND IS NOT COVERED BY THIS WARRANTY.

Some states do not allow limitations on how long an implied warranty lasts, so the above limitation may not apply to you. Some states do not allow the exclusion or limitation of incidental or consequential damages, so the above limitation or exclusion may not apply to you. This warranty gives you specific legal rights, and you may also have other rights, which vary from state to state.



ATD Tools, Inc.  
160 Enterprise Drive  
Wentzville, MO 63385  
[www.atdtools.com](http://www.atdtools.com)



# Notes

---

---

---

---

---

---

---

---

---

---

---

---

---

---

---

---

---

---

---

---

---

---

---

---

---

---

---

---

---

---



ATD Tools, Inc.  
160 Enterprise Drive  
Wentzville, MO 63385  
[www.atdtools.com](http://www.atdtools.com)