



Low Profile SwiftLift™ Service Jack

Operating Instructions & Parts Manual

Model
ATD-7333A

Capacity
2.5 Ton



U.S. Patent No. 6,199,379



This is the safety alert symbol. It is used to alert you to potential personal injury hazards. Obey all safety messages that follow this symbol to avoid possible injury or death.

⚠ WARNING ⚠

WARNING: This product may contain chemicals, including lead, known to the State of California to cause cancer, birth defects or other reproductive harm. *Wash hands after handling.*

Made in China to ATD Tools, Inc. Specifications
Visit us at www.atdtools.com

Printed in China
ATD7333A_rev_0417

SAFETY AND GENERAL INFORMATION

Save these instructions. For your safety, read, understand, and follow the information provided with and on this device before using. The owner and/or operator shall have an understanding of the device, its operating characteristics and safety operating instructions before operating the equipment. The owner and/or operator shall be aware that use and repair of this product may require special skills and knowledge. Instructions and safety information shall be read to and discussed with the operator in the operator's native language, making sure that the operator comprehends their contents, before use of this equipment is authorized. If any doubt exists as to the safe and proper use of this device, remove from service immediately.

Inspect before each use. Do not use if abnormal conditions such as cracked welds, damaged, loose or missing parts are noted. Any equipment that appears damaged in any way, is found to be worn, or operates abnormally shall be removed from service until repaired. If the equipment has been or is suspected to have been subjected to an abnormal load or shock, immediately discontinue use until inspected by a factory authorized repair facility (contact distributor or manufacturer for list of authorized repair facilities). It is recommended that an annual inspection be made by an authorized repair facility. Labels and Operator's Manuals are available from the manufacturer.

PRODUCT DESCRIPTION

This Hydraulic Service Jack is designed to lift, but not support, one end of a vehicle. Immediately after lifting, loads must be supported by a pair of appropriately rated jack stands.

⚠ WARNING: *Never use a hydraulic jack as a stand-alone device. After lifting, immediately support the lifted vehicle with a pair of appropriately rated jack stands.*

SPECIFICATIONS

Model	Capacity	Jack Size (L x W x H)	Minimum Height	Maximum Height	Saddle Diameter	Handle Length	Front Casters	Weight
ATD-7333A	2.5 Ton	27.72" x 13.15" x 5.95"	3.35"	19.3"	4.33"	42.13"	2-1/2" Dia. x 2" W	69.5 lbs.

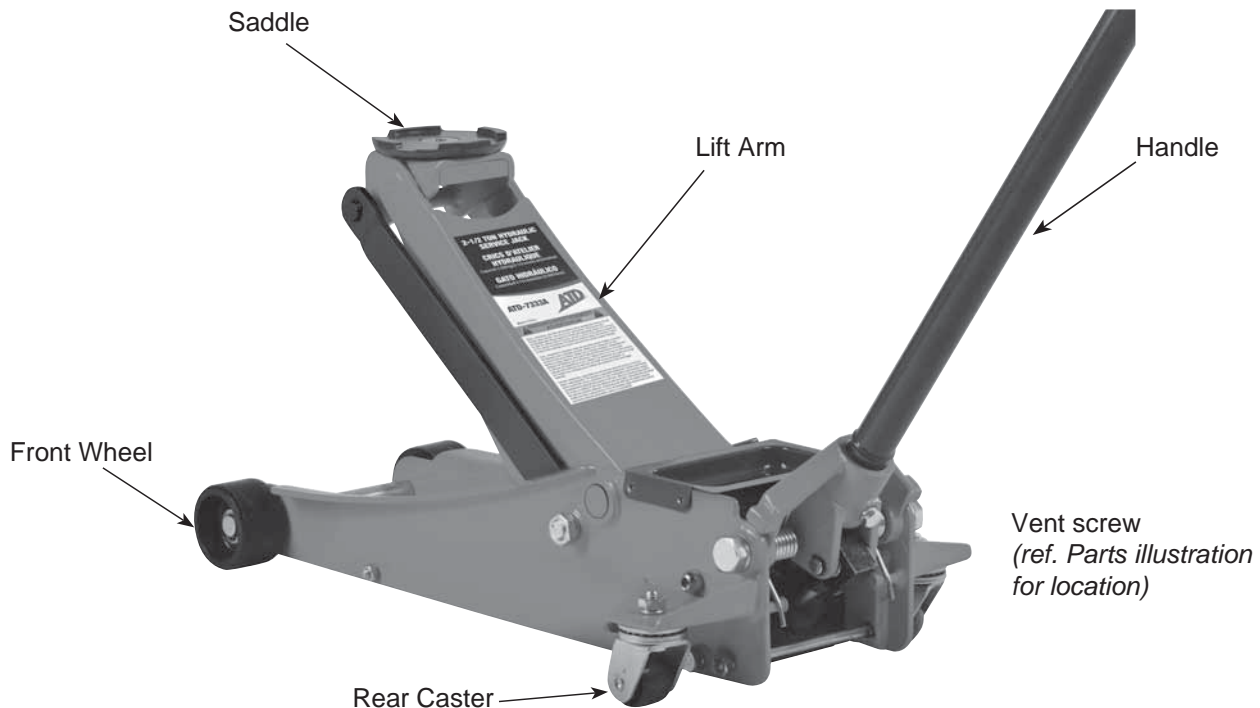

Figure 1 - Service Jack nomenclature

ASSEMBLY

Always secure the handle into the handle sleeve by means of the bolt lock washer and nut provided. Tighten securely to prevent accidental removal of handle while in use. Familiarize yourself with the illustrations in the operator's manual. Know your jack and how it operates before attempting to use.

BEFORE USE

1. Verify that the product and the application are compatible, if in doubt call for Technical Service (888) 332-6419.
2. Before using this product, read the operator's manual completely and familiarize yourself thoroughly with the product, its components and recognize the potential hazards associated with its use.
3. Open the release valve by turning the handle counter-clockwise (no more than 1/2 full turn).
4. With saddle fully lowered, locate and remove the oil filler plug/screw. Pump handle 6 to 8 full strokes. Ensure the oil level is within ~ 3/16" from the inner cylinder as viewed from the oil filler hole. Reinstall the oil filler plug/screw. Close release valve by turning the handle clockwise until firm resistance is felt.
5. Check to ensure that jack rolls freely, that the pump and release valve operate smoothly. Raise and lower the unloaded saddle throughout the advertised lift range before putting into service.
6. Replace worn or damaged parts and assemblies with factory authorized replacement parts only. (See Replacement Parts section). Lubricate as instructed in Maintenance section.

WARNING

- Study, understand, and follow all instructions before operating this device.
- Do not exceed rated capacity.
- Use only on hard, level surface.
- Lifting device only. Immediately after lifting, support the vehicle with appropriate means.
- Do not move or dolly the vehicle while on the jack.
- Lift only on areas of the vehicle as specified by the vehicle manufacturer.
- No alterations shall be made to this product.
- Failure to heed these markings may result in personal injury and/or property damage.

OPERATION

Lifting

CAUTION

Lift only areas of the vehicle as specified by the vehicle manufacturer.
Do not use adapters or accessories that are not provided initially.
The result of overloading may cause hydraulic system failure.

1. Place vehicle in park, with emergency brake on and wheels securely chocked to prevent inadvertent vehicle movement.
2. Locate and close release valve by turning handle clockwise, firmly. Center jack saddle under lift point.
3. Verify lift point, then use handle pump to contact lift point. To lift, pump handle until load reaches desired height.
4. Transfer the load immediately to appropriately rated jack stands.

WARNING



To avoid crushing and related injuries:
NEVER work on, under or around a load supported only by jack. ALWAYS use adequately rated jack stands.

Lowering

WARNING

Be sure all tools and personnel are clear before lowering load.

1. Raise load high enough to clear the jack stands, then carefully remove jack stands (**always** used in pairs).
2. Slowly turn the handle counterclockwise, but no more than 1/2 turn. If the load fails to lower:
 - a. Use another jack to raise the vehicle high enough to reinstall jack stands.
 - b. Remove the affected jack and then the stands.
 - c. Using the other jack, lower the load by turning the operating handle counter-clockwise, but no more than 1/2 turn.
3. After removing jack from under the load, push saddle down to reduce ram exposure to rust and contamination.

MAINTENANCE

Important: Use only good grade hydraulic jack oil. Avoid mixing different types of fluid and NEVER use brake fluid, turbine oil, transmission fluid, motor oil or glycerin. Improper fluid can cause premature failure of the jack and the potential for sudden and immediate loss of load. We recommend Mobil DTE 13M or equivalent.

Adding oil

1. With saddle fully lowered set jack in its upright, level position. Locate and remove oil filler plug/screw.
2. Fill with oil until ~3/16" above the inner cylinder as seen from the oil filler hole. Reinstall the oil filler plug/screw.

Changing oil

For best performance and longest life, replace the complete fluid supply at least once per year.

1. With saddle fully lowered, remove the oil filler plug/screw.
2. Lay the jack on its side and drain the fluid into a suitable container.

Note. Dispose of hydraulic fluid in accordance with local regulations.

3. Fill with oil until ~3/16" above the inner cylinder as seen from the oil filler hole. Reinstall oil filler plug/screw.

Lubrication

A periodic coating of light lubricating oil to pivot points, axles and hinges will help to prevent rust and assure that wheels, casters and pump assemblies move freely.

Cleaning

Periodically check the pump piston and ram for signs of rust or corrosion. Clean as needed and wipe with an oily cloth.

Note: Never use sandpaper or abrasive material on these surfaces!

Storage

When not in use, store the jack with saddle fully lowered.

REPLACEMENT PARTS

Not all components of the jack are replacement items, but are illustrated as a convenient reference of parts location. When ordering parts, give part number and parts description. Call your distributor for current pricing.

TROUBLESHOOTING

Symptom	Possible Causes	Corrective Action
Jack will not lift load	<ul style="list-style-type: none"> • Release valve not tightly closed • Overload condition 	<ul style="list-style-type: none"> • Ensure release valve tightly closed • Remedy overload condition
Jack will lift, but not maintain pressure	<ul style="list-style-type: none"> • Release valve not tightly closed • Overload condition • Hydraulic unit malfunction 	<ul style="list-style-type: none"> • Ensure release valve tightly closed • Remedy overload condition • Contact Tech. Service (888) 332-6419
Jack will not lower after unloading	<ul style="list-style-type: none"> • Reservoir overfilled • Linkage binding 	<ul style="list-style-type: none"> • Ensure load is removed, then drain fluid to proper level • Clean and lubricate moving parts
Poor lift performance	<ul style="list-style-type: none"> • Fluid level low • Air trapped in system 	<ul style="list-style-type: none"> • Ensure proper fluid level • With ram fully retracted, remove oil filler plug to let pressurized air escape, then reinstall oil filler plug
Will not lift to full extension	<ul style="list-style-type: none"> • Fluid level low 	<ul style="list-style-type: none"> • Ensure proper fluid level

REPLACEMENT PARTS

Not all components of the jack are replacement items, but are illustrated as a convenient reference of parts location. When ordering parts, give model number, part number and parts description. Call your distributor for current pricing.

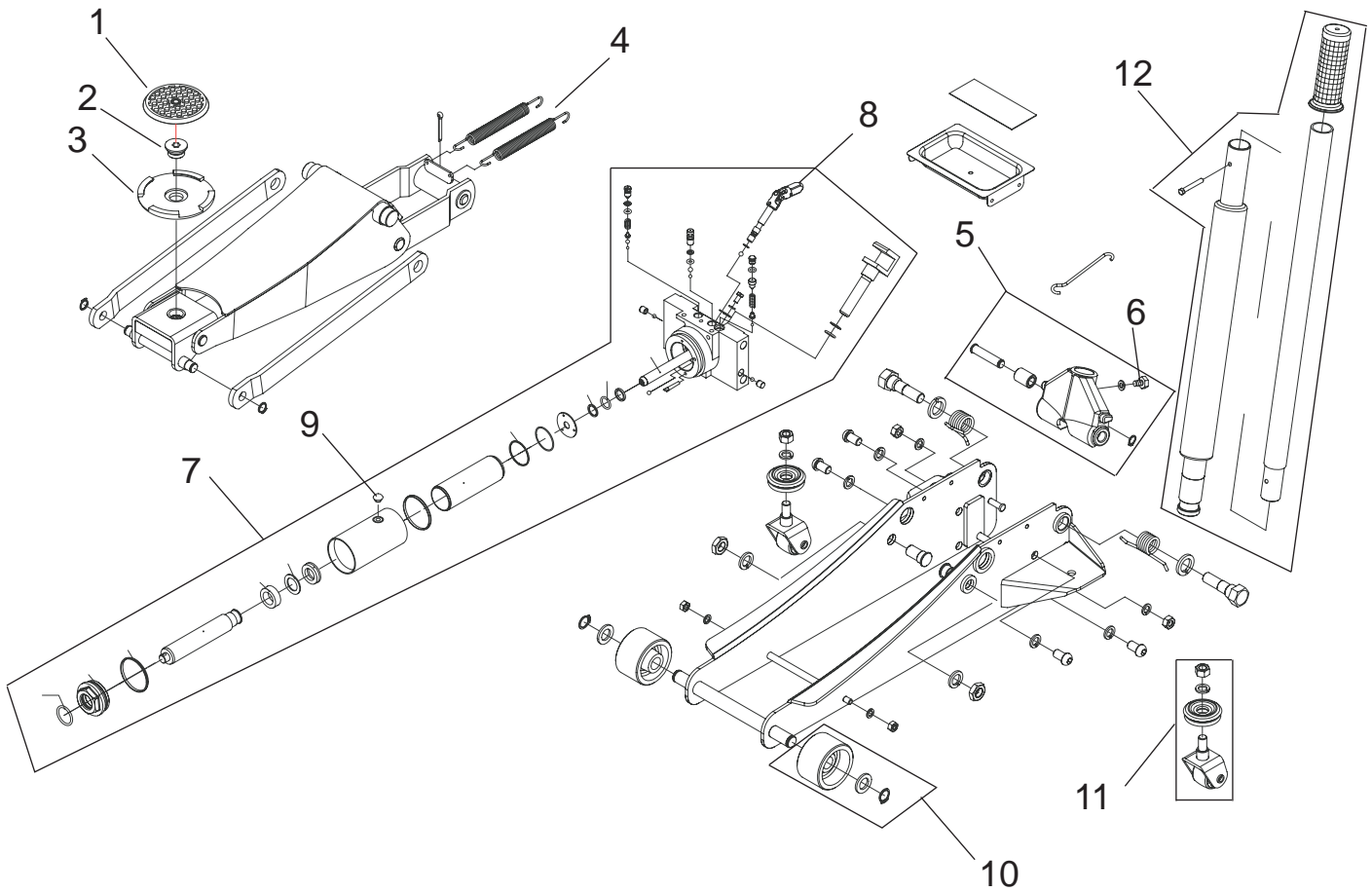

Figure 4 - Replacement Parts Illustration for model ATD-7333A.

(**) Replacement requires special skills, knowledge, and equipment. Only an authorized service center may perform the repair and/or replacement of these items.

Replacement parts list for model ATD-7333A.

ITEM#	ORDERING PART#	PART DESCRIPTION	QTY
1	G500-50002-0440	SADDLE PAD	1
2	K500-10002-0410	SADDLE HOLDING BLOCK	1
3	K500-10001-0000	SADDLE	1
4	G632-10012-0420	RETURN SPRING	2
5	29028-5	HANDLE SLEEVE ASSEMBLY	1
6	G48900-0024	HANDLE LOCK FASTENER	1
7	29028-7	HYDRAULIC UNIT	1
8	G735-32000-0000	U-JOINT	1
9	F36100-0001	RESERVOIR PLUG	1
10	29028-10	FRONT WHEEL ASSEMBLY	2
11	29028-11	REAR CASTER ASSEMBLY	2
12	29028-12	HANDLE	1
13	29028-13	REPAIR KIT, HYDRAULIC	-

ONE YEAR LIMITED WARRANTY

For a period of one (1) year from date of purchase, **ATD Tools, Inc.** will repair or replace, at its option, without charge, any of its products which fails due to a defect in material or workmanship, or which fails to conform to any implied warranty not excluded hereby.

Performance of any obligation under this warranty may be obtained by contacting your distributor or point of sale for further instructions. Please retain your proof of purchase, as it will be needed for any claim.

Except where such limitations and exclusions are specifically prohibited by applicable law, (1) the CONSUMER'S SOLE AND EXCLUSIVE REMEDY SHALL BE THE REPAIR OR REPLACEMENT OF DEFECTIVE PRODUCTS AS DESCRIBED ABOVE, and (2) **ATD Tools, Inc.** SHALL NOT BE LIABLE FOR ANY CONSEQUENTIAL OR INCIDENTAL DAMAGE OR LOSS WHATSOEVER, and (3) THE DURATION OF ANY AND ALL EXPRESSED AND IMPLIED WARRANTIES, INCLUDING WITHOUT LIMITATION, ANY WARRANTIES OF MERCHANTABILITY AND FITNESS FOR A PARTICULAR PURPOSE, IS LIMITED TO A PERIOD OF ONE (1) YEAR FROM DATE OF PURCHASE.

Some states do not allow limitations on how long an implied warranty lasts, so the above limitation may not apply to you. Some states do not allow the exclusion or limitation of incidental or consequential damages, so the above limitation or exclusion may not apply to you. This warranty gives you specific legal rights, and you may also have other rights which vary from state to state.



