



Air / Hydraulic Axle Jack

Operating Instructions & Parts Manual

Model Number

**ATD-7322
Series A**

ATD-7328

Capacity

22 Ton

22 Ton

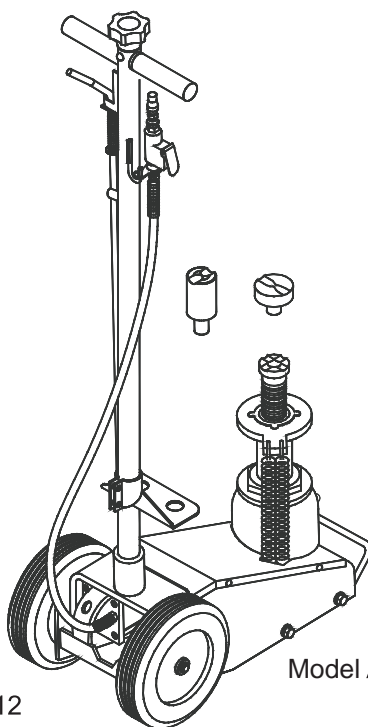

Model ATD-7322 Series A

U.S. Patent No's. 5,341,723 • 5,946,912



This is the safety alert symbol. It is used to alert you to potential personal injury hazards. Obey all safety messages that follow this symbol to avoid possible injury or death.

ADVERTENCIA

- Leer, comprender, y seguir las instrucciones antes de utilizar el aparato.
- El manual de instrucciones y la información de seguridad deben estar comunicado en lengua del operador antes del uso.
- No seguir estas indicaciones puede causar daños personales o materiales.

WARNING

To avoid **crushing and related injuries**:



NEVER work on, under or around a load supported only by a hydraulic jack. **ALWAYS** use adequately rated jack stands.

WARNING

WARNING: This product may contain chemicals, including lead, known to the State of California to cause cancer, birth defects or other reproductive harm. *Wash hands after handling.*

SAFETY AND GENERAL INFORMATION

Save these instructions. For your safety, read, understand, and follow the information provided with and on this jack before using. The owner and operator of this equipment shall have an understanding of this jack and safe operating procedures before attempting to use. The owner and operator shall be aware that use and repair of this product may require special skills and knowledge. Instructions and safety information shall be conveyed in the operator's native language before use of this jack is authorized. If any doubt exists as to the safe and proper use of this jack, remove from service immediately.

Inspect before each use. Do not use if broken, bent, cracked or damaged parts are noted. Any jack that appears damaged in any way, or operates abnormally shall be removed from service immediately. If the jack has been or suspected to have been subjected to a shock load (a load dropped suddenly, unexpectedly upon it), immediately discontinue use until jack has been checked by a factory authorized service center (contact distributor or manufacturer for list of authorized service centers). It is recommended that an annual inspection be done by qualified personnel. Labels and Operator's Manuals are available from manufacturer.

PRODUCT DESCRIPTION

These Air/Hydraulic Axle Jack are designed to lift, but not support, rated capacity partial vehicle loads consisting of one end of a vehicle. **Immediately** after lifting, loads must be supported by a pair of appropriately rated jack stands.



NEVER use a hydraulic truck jack as a stand-alone device. After lifting, **immediately** support the lifted vehicle with a pair of appropriately rated jack stands.

PREPARATION

Assembly (see Replacement Parts page 6 for reference to parts location & assembly sequence)

Assemble, align and insert the handle assembly and handle position bar into the handle sleeve, then tighten the bolt on handle sleeve to prevent accidental removal of handle while in use.

Before Use

1. Verify that the product and application are compatible, if in doubt call the Technical Service line (888) 332-6419.
2. Before using this product, read the operator's manual completely and familiarize yourself thoroughly with the product, its components and recognize the hazards associated with its use.
3. To familiarize yourself with basic operation, locate and turn the release valve (handle knob):
 - a. Clockwise until firm resistance is felt to further turning. This is the '**CLOSED**' release valve position used to **raise** the load.
 - b. Counter-clockwise, but no more than 1 full turn from the closed position. This is the '**OPEN**' release valve position used to **lower** the load. The more you turn the release valve counter-clockwise, the faster the load descends.
4. With ram fully lowered, remove the oil filler screw. Check oil level. Proper oil level should be just below the rim of the opening. Reinstall the oil filler screw.
5. Pour a teaspoon of good quality air tool lubricant into the air supply inlet of the lift control valve. Connect to air supply, then squeeze the lift control valve for 3 seconds to evenly distribute lubricant.

Note: These models are equipped with the popular 1/4" NPT air coupler. When installing a different air coupler of your choice, ensure that thread tape or compound is used when servicing connections. To ensure dependable, trouble free operation an inline air dryer and oiler is recommended.
6. Ensure that jack rolls freely. Raise and lower the unloaded ram throughout the lifting range before putting into service to ensure the jack operates smoothly. Replace worn or damaged parts and assemblies with factory authorized replacement parts only.

Bleeding / Venting Trapped Air

With the release valve in the OPEN position (3b.) and with ram fully lowered, locate and remove the oil filler screw. This will help release any pressurized air which may be trapped within the reservoir. Reinstall the oil filler screw.

SPECIFICATIONS

Model	Capacity	Jack Size (L x W)	Min. Height	Max. Height w/adapter	Adapter	Extension Screw	Weight
ATD-7322 Series A	22 Ton	22-7/8" x 13-3/4"	9-3/4"	21-3/4"	2-1/2"	3-7/8"	100 lbs.
ATD-7328	22 Ton	22" x 12-5/8"	8-1/4"	21-7/8"			95 lbs.

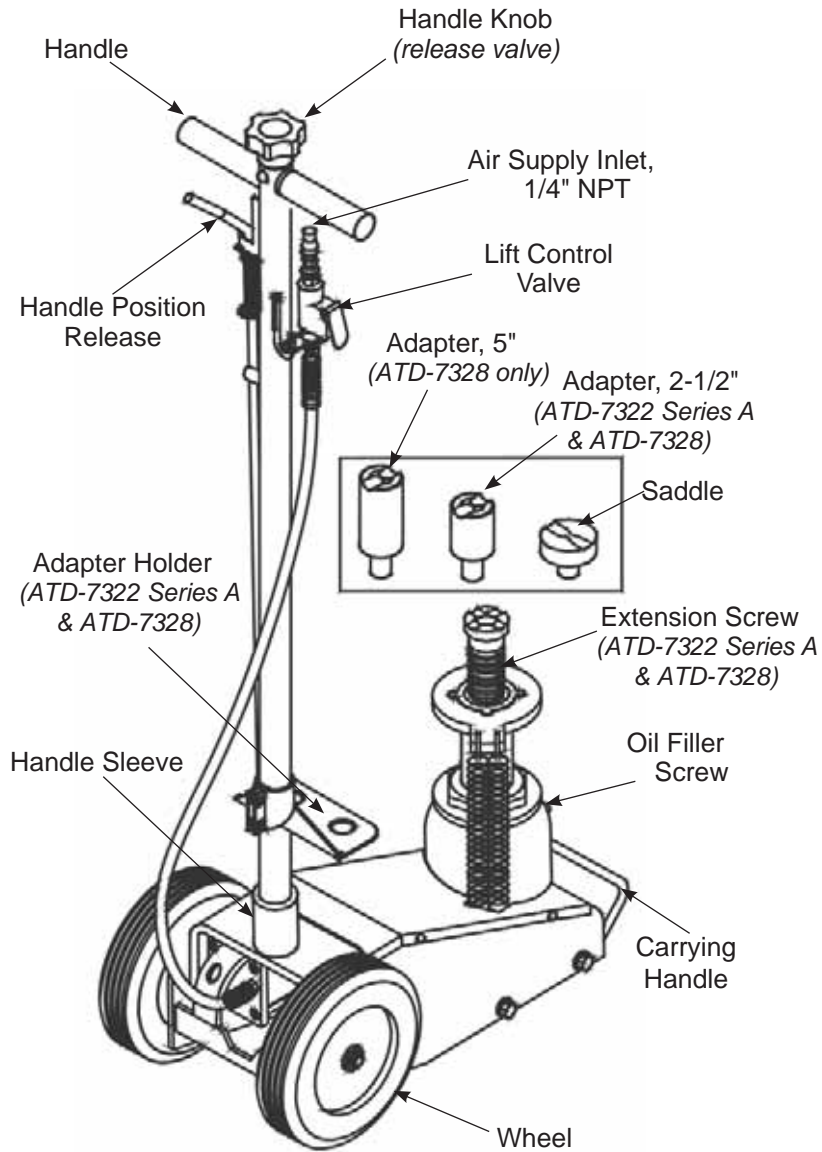
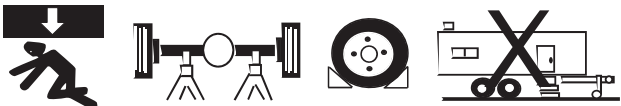

Figure 1 - Typical Truck Jack nomenclature (Model ATD-7328 shown)

⚠ WARNING

- **Study, understand, and follow** all printed materials provided with/on this product before use.
- **Do not** exceed rated capacity.
- **This is a lifting device only!**
- **Immediately** after lifting, support the load with a **pair** of appropriately rated jack stands.
- Use **only** on hard, level surface.
- **Lift only** on areas of the vehicle as specified by the vehicle manufacturer.
- **Never** wire, clamp or otherwise disable the lift control valve to function by other than operator's hand.
- No alterations shall be made to this product.
- **Failure** to heed these markings may **result in personal injury and/or property damage.**

⚠ WARNING



To avoid **crushing and related injuries**:

- **Never** work on, under or around a load supported only by hydraulic jack.
- **Always** use adequately rated jack stands.
- Chock each unlifted tire in both directions.
- **Do not** use this device to lift, level, lower, support nor move a house, mobile home, travel trailer, camper or any building structure.
- **Be alert and sober** when using this product. Do not operate under the influence of drugs or alcohol.

⚠ *The wheels provided with this jack are for positioning the jack under a load **ONLY!** The wheels are **not** load wheels. Do not try to dolly or move the vehicle with the jack!*

OPERATION (see Fig 1)

Lifting

Note: The jack is equipped with handle position lock. To adjust the handle, release lock device by pulling the lever up, lever is spring loaded and will lock into desired position. Ensure lever locking mechanism is fully engaged before lifting.

1. Connect adequate air source to the air supply inlet.
2. Follow the vehicle manufacturer's recommended guidelines for lifting. Engage the emergency brake and chock each unlifted wheel in both directions to prevent inadvertent vehicle movement.
3. Close the release valve by turning the handle knob clockwise until firm resistance is felt.
4. Center jack saddle under lift point, then squeeze the lift control valve until saddle contacts the lift point. To lift, continue squeezing the lift control valve until load reaches desired height. Simply release your grip on the lift control valve to end lift event.
5. Transfer the load **immediately** to appropriately rated jack stands.

⚠ *Only attachments and/or adapters supplied by the manufacturer shall be used. Lift only on area of the vehicle as specified by the vehicle manufacturer.*

⚠ ***NEVER** use hydraulic jack as a stand alone device! **ALWAYS** transfer the lifted load **IMMEDIATELY** to a pair of appropriately rated jack stands. Use one pair of jack stands per vehicle. Rated capacity is per pair only! Do not exceed rated capacity.*

Lowering

⚠ *Be sure all tools and personnel are clear before lowering load. **Slowly open the release valve!** The more you turn the handle knob counter-clockwise, the faster the load will come down. **Maintain control** of the rate of speed at which the load lowers at all times!*

1. Raise load high enough to clear the jack stands.
2. Remove jack stands carefully (**always** used in pairs).
3. **Slowly** turn handle knob counter-clockwise, but no more than 1 full turn. If the load fails to lower:
 - a. Use another jack to raise the vehicle high enough to reinstall jack stands.
 - b. Remove the malfunctioning jack and then the jack stands.
 - c. Use the functioning jack to lower the vehicle.
4. After removing jack from under the vehicle, fully retract the jack to reduce ram exposure to rust and contamination.

MAINTENANCE

Important: Use only good grade hydraulic jack oil. Avoid mixing different types of fluid and NEVER use brake fluid, turbine oil, transmission fluid, motor oil or glycerin. Improper fluid can cause premature failure of the jack and the potential for sudden and immediate loss of load. We recommend Mobil DTE 13M or equivalent.

Adding/ Changing Oil

For best performance and longest life, replace the complete fluid supply at least once per year.

1. With saddle fully lowered remove cover plate, then oil filler screw.
2. Lay jack on its side and drain fluid into a suitable container.
Note: Dispose of hydraulic fluid in accordance with local regulations.
3. Set jack in its upright, level position.
4. Fill with oil. Proper oil level is just below the rim of the opening. Reinstall the oil filler screw.

Lubrication

A periodic coating of light lubricating oil to pivot points, axles and hinges will help to prevent rust and assure that wheels move freely and the pump functions smoothly. To help ensure trouble free operation, an inline air dryer and oiler is recommended.

Cleaning

Periodically check the ram for signs of rust or corrosion. Clean as needed and wipe with an oily cloth.

Note: Never use sandpaper or abrasive material on ram surfaces!

Storage

When not in use, store the jack with saddle fully lowered.

TROUBLESHOOTING

Symptom	Possible Causes	Corrective Action
Jack will not lift load	<ul style="list-style-type: none"> • Release valve not tightly closed • Load is too heavy • Air supply inadequate 	<ul style="list-style-type: none"> • Ensure release valve tightly closed • Consider higher capacity jack • Ensure adequate air supply
Jack will lift, but not maintain pressure	<ul style="list-style-type: none"> • Release valve not tightly closed • Hydraulic unit malfunction 	<ul style="list-style-type: none"> • Ensure release valve tightly closed • Discontinue use, contact Technical Service (888) 332-6419
Jack will not lower after unloading	<ul style="list-style-type: none"> • Reservoir overfilled • Linkages binding 	<ul style="list-style-type: none"> • Drain fluid to proper level • Clean and lubricate moving parts
Poor lift performance	<ul style="list-style-type: none"> • Fluid level low • Air trapped in system 	<ul style="list-style-type: none"> • Ensure proper fluid level • With ram fully retracted, remove oil filler screw to let pressurized air escape. Reinstall oil filler screw
Will not lift to full extension	<ul style="list-style-type: none"> • Fluid level low 	<ul style="list-style-type: none"> • Ensure proper fluid level

Replacement Parts for model ATD-7322 Series A and ATD-7328:

Item	Part No.	Description	Qty
1	A070-70000-100	Handle Assembly	1
2	G251-00007-000	Handle Grip	2
3	G251-40001-000	Knob	1
4	5402-04028-000	Spring Pin	1
5	5115-10017-000	Bolt	1
6	5303-00010-100	Washer, Lock	5
7	A070-00006-000	Handle Sleeve	1
8	A090-00001-000	Cover Plate	1
9	5110-06010-000	Screw	4
10	A070-00001-000	Wheel	2
11	5308-00013-006	Washer	2
12	5304-00013-000	C-clip	2
13	G831-03200-000	Air Motor	1
14	5102-10025-000	Bolt	4
15	5308-00095-000	Copper Gasket	1
16	A220-01000-000	Air Hose Assembly	1
17	A240-02100-000	Air Hose	1
18	A240-02200-000	Lift Control Valve	1
19	A240-02400-000	Air Coupler, Male, 1/4 NPT	1
20	A070-3000-000	Release Valve Cable	1
21	A090-12008-000	Release Valve	1
22	5905-00054-000	Oil Seal	1

Item	Part No.	Description	Qty
23	5105-05016-000	Screw	1
24	5102-08025-000	Screw	2
25	5202-00008-000	Nut	2
26	G62S-03301-000	Filler Screw	1
27	A070-00009-000	Spring (for Atd-7322 Series A only)	4
	A091-00002-000	Spring (for Atd-7328)	4
28	A070-11001-000	Extension Screw	1
29	A07-5-1108-105	Saddle	1
30	A070-00008-000	Spring Plate	1
31	A27010-0028	Air Filter	1
32	A0901S-077	Repair Kit (includes #22 & A-F)	-
33	G831-03210-000	Piston, Air Motor #13	1
34	A090-10000-000	Hydraulic Unit (for Atd-7322 Series A only)	1
	A091-90009-K01	Hydraulic Unit (for Atd-7328)	1
35	N/A	Wheel Axle	2
36	A090-00002-000	Base Plate	1
37	A070-81001-000	Adapter Holder	1
38	A070-00015-000	Adapter, 2-1/2"	1
39	A091-00003-000	Adapter, 5" (for Atd-7328 only)	1

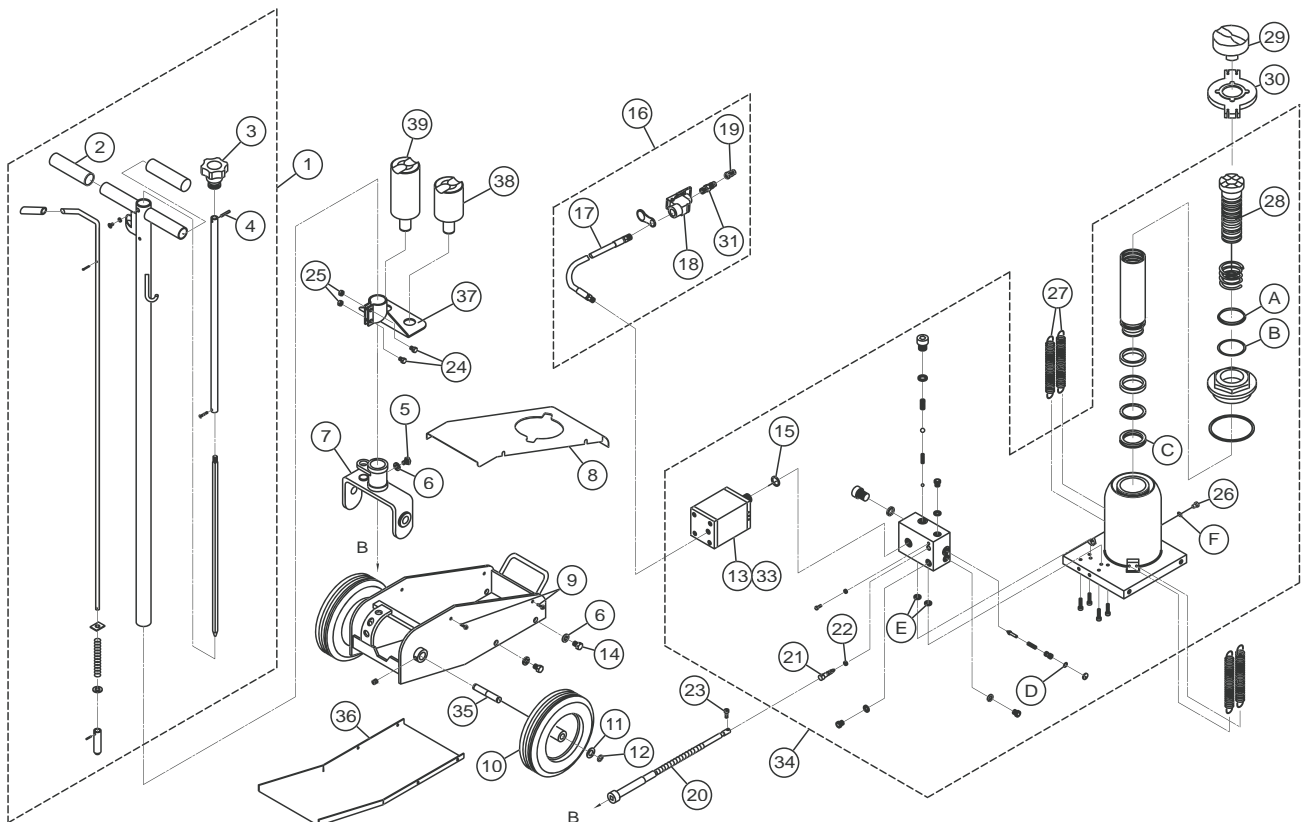

Figure 2 - Replacement Parts Illustration for models ATD-7322 Series A and ATD-7328

REPLACEMENT PARTS

Available Parts: Please refer to the Parts drawing when ordering parts. Not all components of this kit are replacement items, but are illustrated as a convenient reference of location and position in the assembly sequence. When ordering parts, give model number, part number and description. Call your distributor for current pricing.

ONE YEAR LIMITED WARRANTY

For a period of one (1) year from date of purchase, **ATD Tools, Inc.** will repair or replace, at its option, without charge, any of its products which fails due to a defect in material or workmanship, or which fails to conform to any implied warranty not excluded hereby.

Performance of any obligation under this warranty may be obtained by contacting your distributor or point of sale for further instructions. Please retain your proof of purchase, as it will be needed for any claim.

Except where such limitations and exclusions are specifically prohibited by applicable law, (1) the CONSUMER'S SOLE AND EXCLUSIVE REMEDY SHALL BE THE REPAIR OR REPLACEMENT OF DEFECTIVE PRODUCTS AS DESCRIBED ABOVE, and (2) **ATD Tools, Inc.** SHALL NOT BE LIABLE FOR ANY CONSEQUENTIAL OR INCIDENTAL DAMAGE OR LOSS WHATSOEVER, and (3) THE DURATION OF ANY AND ALL EXPRESSED AND IMPLIED WARRANTIES, INCLUDING WITHOUT LIMITATION, ANY WARRANTIES OF MERCHANTABILITY AND FITNESS FOR A PARTICULAR PURPOSE, IS LIMITED TO A PERIOD OF ONE (1) YEAR FROM DATE OF PURCHASE.

Some states do not allow limitations on how long an implied warranty lasts, so the above limitation may not apply to you. Some states do not allow the exclusion or limitation of incidental or consequential damages, so the above limitation or exclusion may not apply to you. This warranty gives you specific legal rights, and you may also have other rights which vary from state to state.



