



Truck Ramps

ATD-7320 and ATD-7321

20-Ton Truck Ramps

Operating Instructions & Parts Manual

Capacity per pair
20 Ton

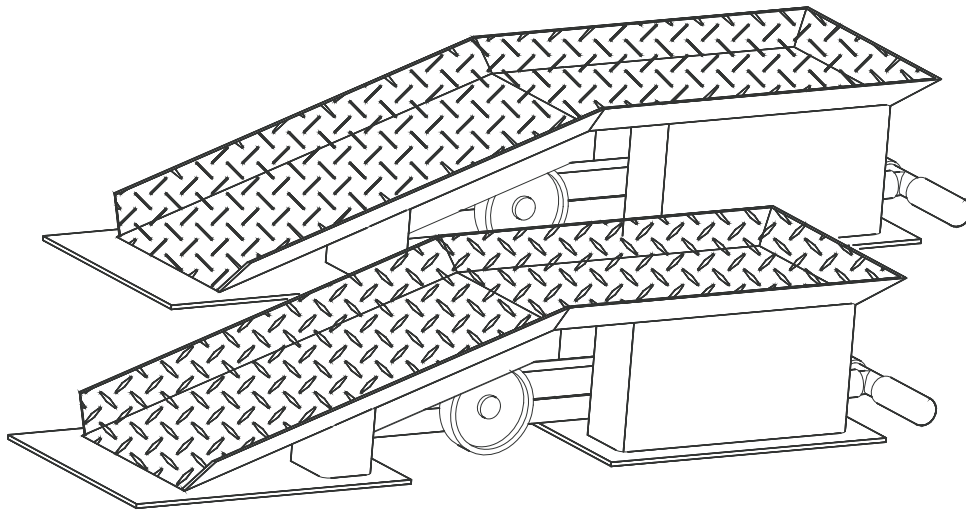

⚠ WARNING ⚠

WARNING: This product may contain chemicals, including lead, known to the State of California to cause cancer, birth defects or other reproductive harm. *Wash hands after handling.*

Made in China to ATD Tools, Inc. Specifications
Visit us at www.atdtools.com

Printed in China
ATD7320_ATD7321_rev_0417

Save these instructions. For your safety, *read, understand and follow* the information contained within. The owner and operator shall have an understanding of this product and safe operating procedures before attempting to use this product. Instructions and Safety information shall be conveyed in the operators native language before use of this product is authorized. Make certain that the operator thoroughly understands the inherent dangers associated with the use and misuse of the product. If any doubt exists as to the safe and proper use of this product as outlined in this factory authorized manual, remove from service. **Inspect before each use.** Do not use if there are broken, bent, cracked or otherwise damaged parts (including labels). If the ramp operates abnormally, discontinue use until inspected by a factory authorized service center. Owners and operators of this equipment shall be aware that the use of this equipment may require special training and knowledge. It is recommended that an annual inspection be done by qualified personnel and that any missing or damaged decals, warning / safety labels or signs be replaced with factory authorized replacements only. Any truck ramp that appears to be damaged in structure shall be removed from service and destroyed immediately.

PRODUCT DESCRIPTION

ATD Tools Truck Ramps are designed to safely support rated capacity vehicles for extended periods. Truck ramps are not to be used to simultaneously support both ends or one side of a vehicle. Heavy gauge steel frame helps prevent distortion and twisting. These ramps comply with applicable **ASME / ANSI** Standards to ensure safety, strength and stability.

IMPORTANT: RATED CAPACITY IS PER PAIR ONLY! TRUCK RAMPS MUST BE USED IN PAIR AND USE ONLY ONE PAIR PER VEHICLE.

DO NOT USE FOR ANY PURPOSE OTHER THAN THOSE USES OUTLINED ABOVE!

SPECIFICATIONS

Model	Capacity	Product Size (L x W x H)	Handle Length	Max. Vehicle Tire Width	Weight (pair)
ATD-7320	20 Ton	45-5/8" x 13-1/2" x 9-1/4"	33"	10-3/4"	274 lbs.
ATD-7321		45-5/8" x 18-1/4" x 9-1/4"		15-1/2"	338 lbs.

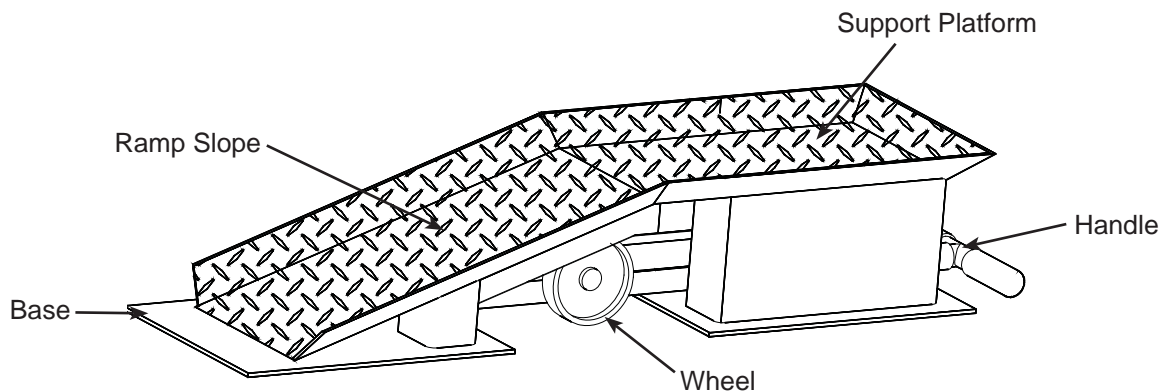

Figure 1 - Truck Ramp Components

BEFORE USE

1. Verify that the product and the application are compatible.
2. Before using this product, read the operator's manual completely and familiarize yourself thoroughly with the product and the hazards associated with its improper use.
3. Inspect before each use. Do not use if bent, broken or cracked components are noted.
4. Ensure that all parts move freely.



WARNING

- Study, understand, and follow all instructions provided before attempting to use this equipment.
- **Rated capacity is per pair!** Do not exceed rated capacity.
- Use only on hard, level surfaces capable of sustaining rated capacity loads.
- Center load between the sides of the ramp.
- Use as a matched pair to support one end of a vehicle. One pair per vehicle only.
- Ramps are not to be used to simultaneously support both ends or one side of a vehicle.
- Do not use other lifting equipment in conjunction with the ramps.
- Ensure other persons are clear from the vehicle path and the ramps.
- Never accelerate or brake suddenly. Proceed slowly and cautiously.
- Do not disconnect brakes, engine, transmission components, drive train, drive shaft, universal joints, or wheels while the vehicle is on the ramps.
- No alterations shall be made to this device
- Failure to heed these markings may result in personal injury and/or property damage.

OPERATION

Lifting

1. Center the two ramps against the tires of vehicle.
2. Ensure that the wheels to be driven on the ramps are positioned straight forward in alignment with the ramps.
3. After positioning the truck ramps, keep the handle in lowest position in order to lower the base to surface. The rubber padded base will prevent ramps movement while vehicle is being driven onto or off the ramps.

Note: Must keep the handle in lowest position in order to lower the base to contact with the floor/surface.

4. Another person, standing clear from vehicle path, should observe and guide the vehicle operator when ascending and descending the ramps.
5. Never accelerate or apply brakes suddenly. Proceed slowly and cautiously.
6. Once the vehicle reaches the top of the ramps, apply brakes only to prevent over-travel.
7. Place the vehicle in neutral. Release brakes; vehicle should not move.
8. Turn the engine off, set parking brake. Place vehicle in park (or in reverse gear for manual transmission).
9. Get out of the vehicle and securely chock the remaining wheels on the ground.
10. Be sure that both tires are properly positioned on the ramp's support platform.
11. Using caution in positioning your body clear of danger, shake vehicle sideways and endways to be sure that vehicle and ramps are stable.
12. Check that ramps have not become damaged or bent during loading.

Lowering



WARNING

Be sure all tools and personnel are clear before lowering load.

1. Another person, standing clear from vehicle path should observe and guide the vehicle operator.
2. Proceed slowly and cautiously, never apply brakes suddenly.
3. After lowering the vehicle, pull the ram handle up to dolly the truck ramp.

MAINTENANCE

Periodically inspect the Truck Ramps. To help prevent rust, wipe clean after each use. If rust appears, sand affected area and cover with suitable utility paint. Store the Truck Ramps in a clean, dry area.

REPLACEMENT PARTS

Not all components of the Truck Ramp are replacement items, but are illustrated as a convenient reference of parts location. When ordering parts, give model number, part number and part description. Contact your distributor for current pricing.

Item	ATD-7320 Part#	ATD-7321 Part#	Description	Qty
1	93200-01	93200-01	Handle Assembly	1
2	93200-02	93200-02	Wheel Assembly, 5 1/8"	2
3	93200-03	93200-03	Handle Grip	2
-	ATD7320-L0	ATD7321-L0	Label	1
-	ATD7320-M0	ATD7320-M0	Manual	1

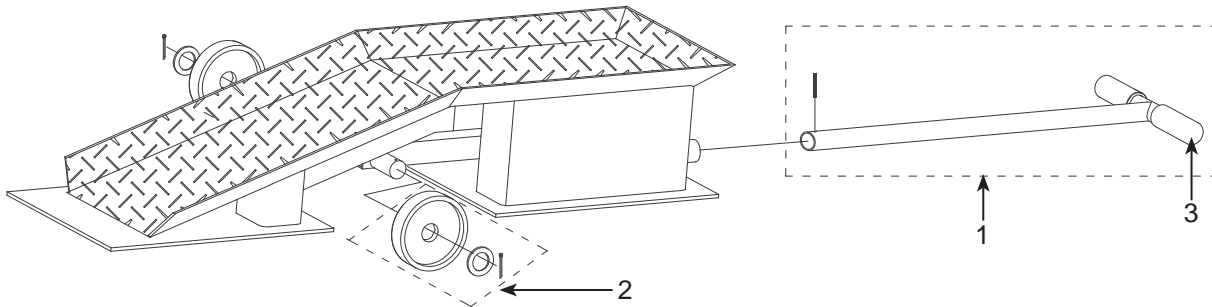

Figure 2 - Truck Ramp Parts Illustration

ONE YEAR LIMITED WARRANTY

For a period of one (1) year from date of purchase, **ATD Tools, Inc.** will repair or replace, at its option, without charge, any of its products which fails due to a defect in material or workmanship, or which fails to conform to any implied warranty not excluded hereby.

Performance of any obligation under this warranty may be obtained by contacting your point of sale and obtaining return or repair information from your supplier.

Except where such limitations and exclusions are specifically prohibited by applicable law, (1) the CONSUMER'S SOLE AND EXCLUSIVE REMEDY SHALL BE THE REPAIR OR REPLACEMENT OF DEFECTIVE PRODUCTS AS DESCRIBED ABOVE, and (2) **ATD Tools, Inc.** SHALL NOT BE LIABLE FOR ANY CONSEQUENTIAL OR INCIDENTAL DAMAGE OR LOSS WHATSOEVER, and (3) THE DURATION OF ANY AND ALL EXPRESSED AND IMPLIED WARRANTIES, INCLUDING WITHOUT LIMITATION, ANY WARRANTIES OF MERCHANTABILITY AND FITNESS FOR A PARTICULAR PURPOSE, IS LIMITED TO A PERIOD OF ONE (1) YEAR FROM DATE OF PURCHASE.

Some states do not allow limitations on how long an implied warranty lasts, so the above limitation may not apply to you. Some states do not allow the exclusion or limitation of incidental or consequential damages, so the above limitation or exclusion may not apply to you. This warranty gives you specific legal rights, and you may also have other rights which vary from state to state.

