

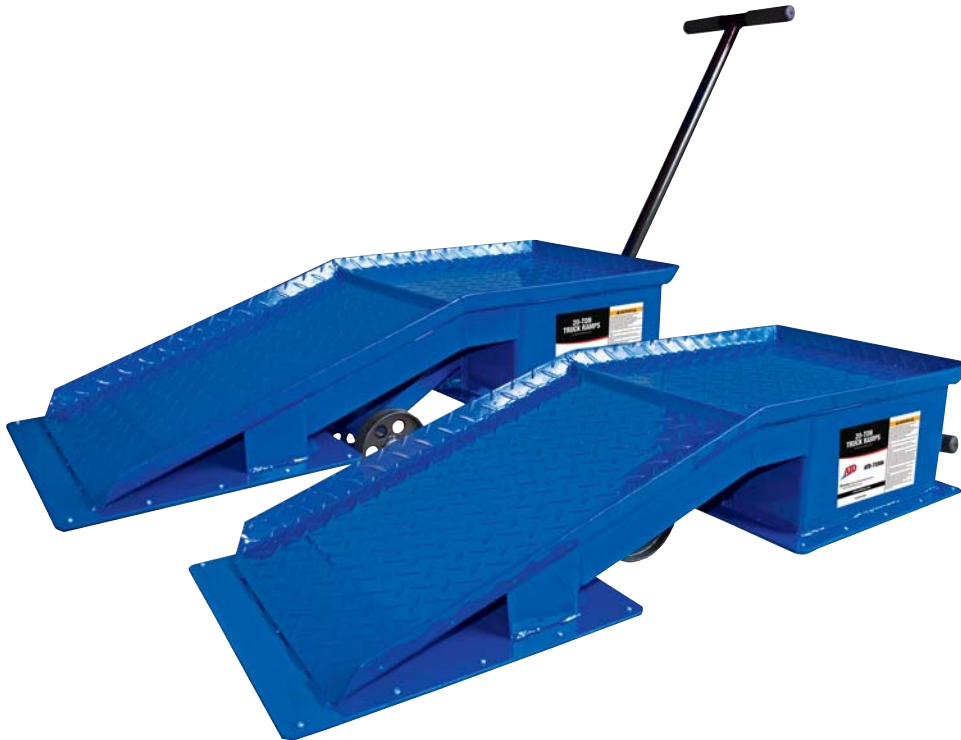

## ATD-7320A Truck Ramps Owner's Manual



**Capacity: 20 Ton**  
(per pair)

### Features:

- Designed specifically for heavy-duty tasks
- Large wheel designs for extra durability
- Non-skid rubber matting prevents movement to enhance operation safety
- Long retractable T-handle for easy positioning
- SOLD AND TO BE USED ONLY IN PAIRS
- ASME/PASE 2014 certified

### Specifications:

- Capacity (per pair): 20-Ton
- Frame Size: 45-5/8" L x 13-1/2" W x 9-1/2" H
- Handle Length: 33-7/8"
- Max Vehicle Tire Width: 10-3/4"
- Weight (pair): 274 lbs.



The safety symbol is used to alert you to potential personal injury hazards. Obey all safety messages that follow this symbol to avoid possible injury or property damage.

**Read this manual and follow all Safety Rules and Operating Instructions before using this product.**

**Save these instructions.** For your safety, *read, understand and follow* the information contained within. The owner and operator should have an understanding of this product and safe operating procedures before attempting to use this product. Instructions and safety information should be conveyed in the operator's native language before use of this product is authorized. Make certain that the operator thoroughly understands the inherent dangers associated with the use and misuse of the product. If any doubt exists as to the safe and proper use of this product as outlined in this factory authorized manual, remove from service.

**Inspect before each use.** Do not use if there are broken, bent, cracked or otherwise damaged parts (including labels). If the ramp operates abnormally, discontinue use until inspected by an ATD authorized service center. Owners and operators of this equipment shall be aware that the use of this equipment may require special training and knowledge. It is recommended that an annual inspection be done by qualified personnel and that any missing or damaged decals, warning / safety labels or signs be replaced with factory authorized replacements only. Any truck ramp that appears to be damaged in structure shall be removed from service and destroyed immediately.

**PRODUCT DESCRIPTION:**

ATD Truck Ramps are designed to safely support rated capacity vehicles for extended periods. Truck ramps are not to be used to simultaneously support both ends or one side of a vehicle. Heavy gauge steel frame helps prevent distortion and twisting. These ramps comply with applicable **ASME/PASE** Standards to ensure safety, strength and stability.

**NOTICE: RATED CAPACITY IS PER PAIR ONLY! TRUCK RAMPS MUST BE USED IN PAIRS AND USE ONLY ONE PAIR PER VEHICLE.**

**DO NOT USE FOR ANY PURPOSE OTHER THAN THOSE USES OUTLINED ABOVE**

**SPECIFICATIONS**

Model	Capacity	Product Size (L x W x H)	Handle Length	Max. Vehicle Tire Width
ATD-7320A	20 Ton	45-5/8" L x 13-1/2" W x 9-1/2" H	33-7/8"	10-3/4"

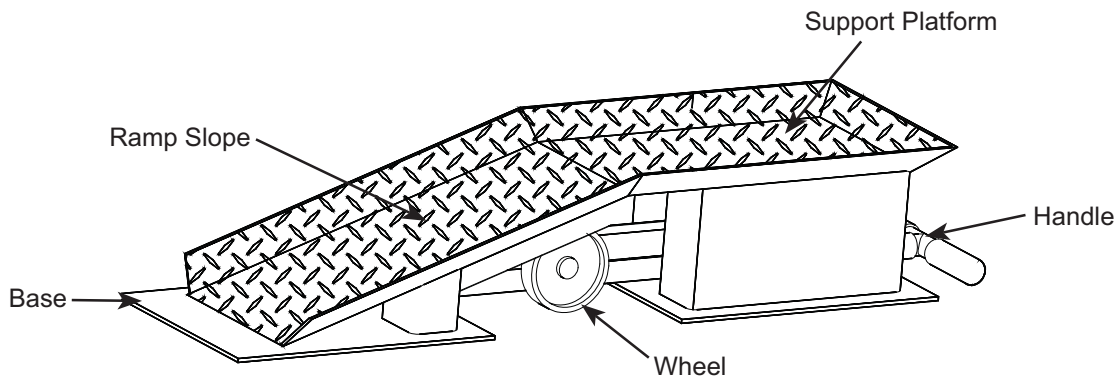

Figure 1 - Truck Ramp Components

## BEFORE USE:

1. Verify that the product and the application are compatible.
2. Before using this product, read the operator's manual completely and familiarize yourself thoroughly with the product and the hazards associated with its improper use.
3. Inspect before each use. Do not use if bent, broken or cracked components are noted.
4. Ensure that all parts move freely.

## WARNING

- Study, understand, and follow all instructions provided before attempting to use this equipment.
- **Rated capacity is per pair!** Do not exceed rated capacity.
- Use only on hard, level surfaces capable of sustaining rated capacity loads.
- Center load between the sides of the ramp.
- Use as a matched pair to support one end of a vehicle. One pair per vehicle only.
- Ramps are not to be used to simultaneously support both ends or one side of a vehicle.
- Do not use other lifting equipment in conjunction with the ramps.
- Ensure other persons are clear from the vehicle path and the ramps.
- Never accelerate or brake suddenly. Proceed slowly and cautiously.
- Do not disconnect brakes, engine, transmission components, drive train, drive shaft, universal joints, or wheels while the vehicle is on the ramps.
- No alterations shall be made to this device
- Failure to heed these markings may result in personal injury and/or property damage.

## OPERATION:

### Lifting

1. Center the two ramps against the tires of vehicle.
2. Ensure that the wheels to be driven on the ramps are positioned straight forward in alignment with the ramps.
3. After positioning the truck ramps, keep the handle in lowest position in order to lower the base to surface. The rubber padded base will prevent ramp movement while vehicle is being driven onto or off of the ramps.

Note: Must keep the handle in lowest position in order to lower the base to contact with the floor/surface.

4. Another person, standing clear from vehicle path, should observe and guide the vehicle operator when ascending and descending the ramps.
5. Never accelerate or apply brakes suddenly. Proceed slowly and cautiously.
6. Once the vehicle reaches the top of the ramps, apply brakes only to prevent over-travel.
7. Place the vehicle in neutral. Release brakes; vehicle should not move.
8. Turn the engine off, set parking brake. Place vehicle in park (or in reverse gear for manual transmission).
9. Get out of the vehicle and securely chock the remaining wheels on the ground.
10. Be sure that both tires are properly positioned on the ramp's support platform.
11. Using caution in positioning your body clear of danger, shake vehicle sideways and endways to be sure that vehicle and ramps are stable.
12. Check that ramps have not become damaged or bent during loading.

### Lowering

## WARNING

Be sure all tools and personnel are clear before lowering load.

1. Another person, standing clear from vehicle path should observe and guide the vehicle operator.
2. Proceed slowly and cautiously, never apply brakes suddenly.
3. After lowering the vehicle, pull the ram handle up to dolly the truck ramp.

## MAINTENANCE

Periodically inspect the Truck Ramps. To help prevent rust, wipe clean after each use. If rust appears, sand affected area and cover with suitable utility paint. Store the Truck Ramps in a clean, dry area.

## REPLACEMENT PARTS

Not all components of the ramp can be replaced. Please contact your distributor for parts. When ordering parts, please provide the model number, part number, and part description. Contact your distributor for current pricing.

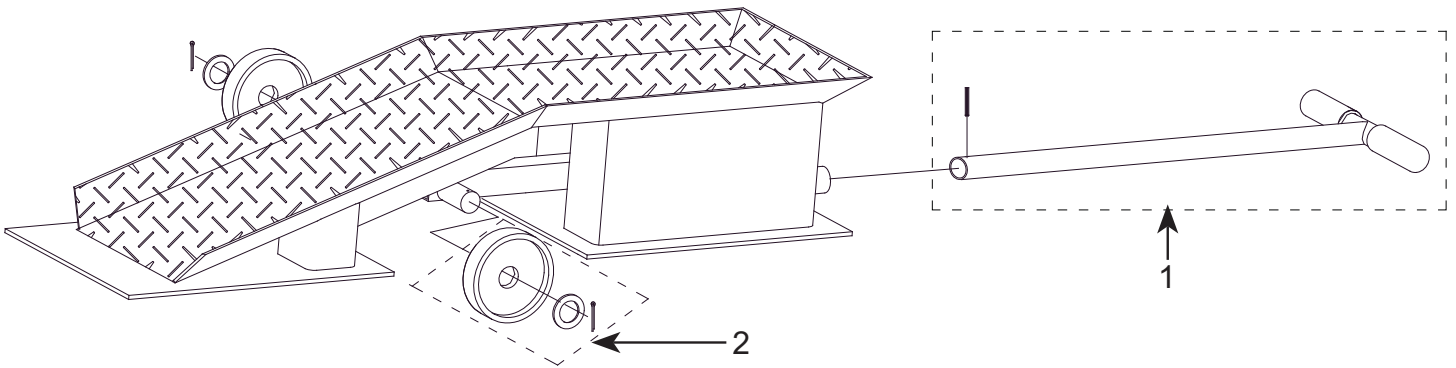

Figure 2 - Truck Ramp Parts Illustration

ITEM#	ORDERING PART#	DESCRIPTION
01	XP20-1	HANDLE ASSEMBLY
02	XP20-2	WHEEL ASSEMBLY (EACH)
N/S	XP20-4	FOOT PAD FOR ATD7320A (PAIR)



# WARRANTY

1 YEAR LIMITED WARRANTY

**THIS WARRANTY AND CONFIRMED RECEIPT(S) SHOULD BE RETAINED BY THE CUSTOMER AT ALL TIMES**

PURCHASED FROM: \_\_\_\_\_

DATE PURCHASED: \_\_\_\_\_

INVOICE/RECEIPT NUMBER: \_\_\_\_\_

Your ATD-7320A is warranted for a period of 12 months from the original purchase date.

For a period of one (1) year from your purchase date, ATD Tools Inc. will repair or replace (at its option) without charge, your ATD product if it was purchased new and the product has failed due to a defect in material or workmanship which you experienced during normal use of the product. This limited warranty is your exclusive remedy.

To access the benefits of this warranty, call 636-327-9050 for warranty information. You may be advised to return the product or a portion of the product under warranty, freight prepaid, to the service department for warranty determination.

If this ATD product is altered, abused, misused, modified, or undergoes service by an unauthorized technician, your warranty will be void. We are not responsible for damage to ornamental designs you place on this ATD product and such ornamentation should not cover any warnings or instructions or they may void the warranty. This warranty does not cover scratches, superficial dents, and other abrasions to the paint finish that occur under normal use. It also does not cover normal wear items such as but not limited to brushes, batteries, drill bits, drill chucks, pads or blades.

Subject to the law in your state:

- (1) Your sole and exclusive remedy is repair or replacement of the defective product as described above.
- (2) ATD is not liable for any incidental damages, including but not limited to, lost profits and unforeseeable consequences.
- (3) The repair and replacement of this product under the express limited warranty described above is your exclusive remedy and is provided in lieu of all other warranties, express or implied. All other warranties, including implied warranties and warranties of merchantability or fitness for a particular purpose are disclaimed and, if disclaimer is prohibited, these warranties are limited to one year from your date of purchase of this product.

Some states' laws do not allow limited durations on certain implied warranties and some states' laws do not allow limitations on incidental or consequential damages. You should consult the law in your state to determine how your rights may vary.

[Affix receipt or invoice here for safe keeping]