



# Hydraulic Wheel Dolly

## Operating Instructions & Parts Manual

**Model Number**  
**ATD-7227**

**Capacity**  
**3/4 Ton (1500 lbs.)**

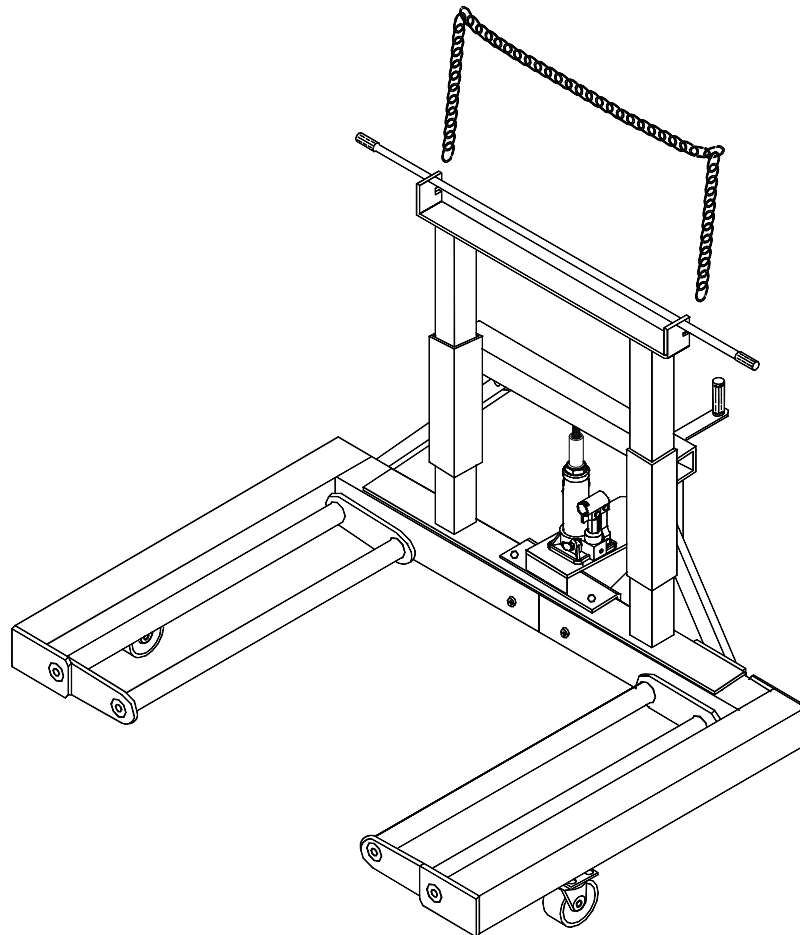

### ⚠ WARNING ⚠

**WARNING:** This product may contain chemicals, including lead, known to the State of California to cause cancer, birth defects or other reproductive harm. *Wash hands after handling.*

**Save these instructions.** For your safety, read and understand the information contained within. The owner and operator shall have an understanding of this product and safe operating procedures before attempting to use this product. Instructions and Safety information shall be conveyed in the operators native language before use of this product is authorized. Make certain that the operator thoroughly understands the inherent dangers associated with the use and misuse of the product. If any doubt exists as to the safe and proper use of this product as outlined in this factory authorized manual, remove from service until which time it is clear. **Inspect before each use.** Do not use if broken, bent, cracked or otherwise damaged parts are noted. If the dolly has been or suspected to have been subjected to a shock load, discontinue use until checked out by an authorized factory service center. Owners and operators of this equipment shall be aware that the use and subsequent repair of this equipment may require special training and knowledge. It is recommended that an annual inspection be done by qualified personnel and that any missing or damaged parts, decals, warning / safety labels or signs be replaced with factory authorized replacement parts only. Any dolly that appears to be damaged in any way, is worn or operated abnormally should be removed from service immediately until such time as repairs can be made.

## PRODUCT DESCRIPTION

ATD Tools Wheel Dolly is designed to facilitate the removal and installation of pneumatic tires and wheel assemblies on trucks, buses and trailers. It is a labor saving device useful in auto shops, bus barns and fleet service.

## SPECIFICATIONS

Model	Capacity	Hydraulic Lift	Lifting Range	Product Size (L x W x H)	Tilt Range	Lifting Arm Dimensions	Net Weight
ATD-7227	3/4 Ton	5"	2-1/4" - 11"	43-1/2" x 43" x 34-7/8"	-2.5° - 10°	25-7/8" x 25-1/4"	183 lbs.

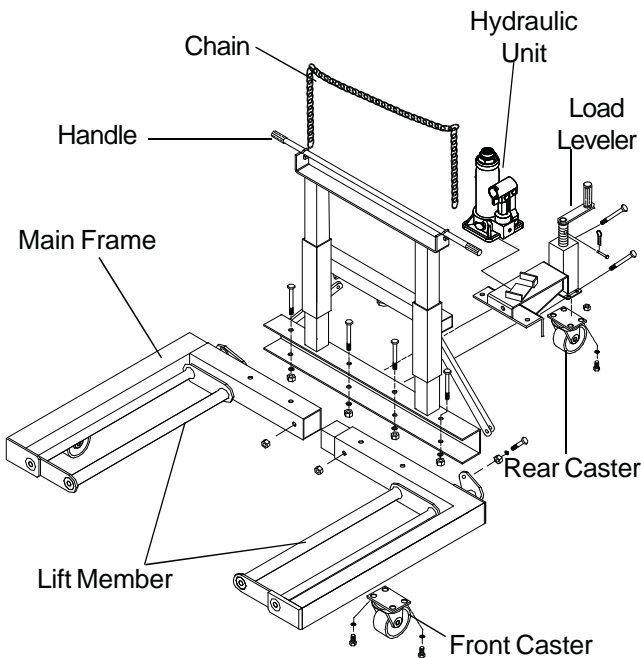

Figure 1- Model ATD-7227 nomenclature

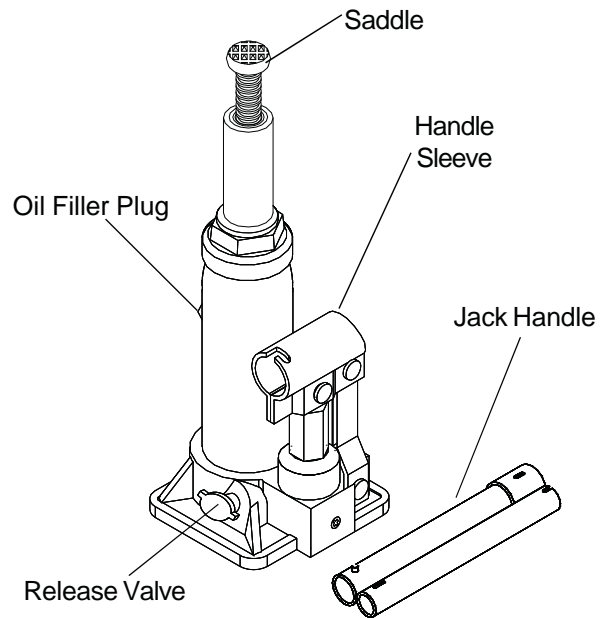

Figure 2- Model ATD-7227 Hydraulic Unit nomenclature

## BEFORE USE

1. Inspect before each use. Do not use if bent, broken, leaking or cracked components are noted. Ensure that casters, rollers and lifting arms move freely. Check and tighten any loose assemblies.
2. Verify that the product and the application are compatible, if in doubt call for Technical Assistance (888) 332-6419.
3. Read, understand and follow vehicle manufacturer's recommended tire change procedures.
4. With ram lowered, locate and remove oil filler plug. This purges the hydraulic system of pressurized air trapped in reservoir. Check fluid level. Proper level is level with filler plug hole.
5. Reinstall oil filler plug.

## ⚠ WARNING

- Read and understand all warnings and instructional material provided on and with this product before use.
- Do not exceed rated capacity.
- Use only on smooth, hard, level surfaces capable of sustaining the load.
- Before moving, lower the load to the lowest possible point and assure that the load is centered and secured with a load restraint device.
- Apply load as close to the vertical position of the lifting arms as possible.
- No alterations shall be made to this product.
- Failure to heed this warning may result in personal injury as well as property damage.

## ASSEMBLY (refer Figure 3 below)

1. Attach front caster (# 1) into left main frame (# 4) and right main frame (# 5) with M8x16 bolts and washers (# 2 & 3).
2. Attach rear caster (# 6) into rear support (# 7), with M8x16 bolts, washers and nuts (# 2, 3 & 16).
3. Insert left main frame (# 4) in right main frame (# 5).
4. Attach upright (# 6) and rear support (# 7) into the main frame assembly with two M12x100 bolts and nuts (#12 & 13) and four M14x110 bolts, washers and nuts (No. 9, 10 & 11).
5. Attach lifting strap (# 14) to the mounting ear of upright and main frame with M8x34 bolts, washers and nuts (# 3, 15 & 16).
6. Attach power unit (# 17) onto the upright assembly.
7. Insert load leveler handle (# 18) to rear support (#7) with bolts and pin (# 19 & 20)
8. Attach the chain (# 21) onto upright assembly.

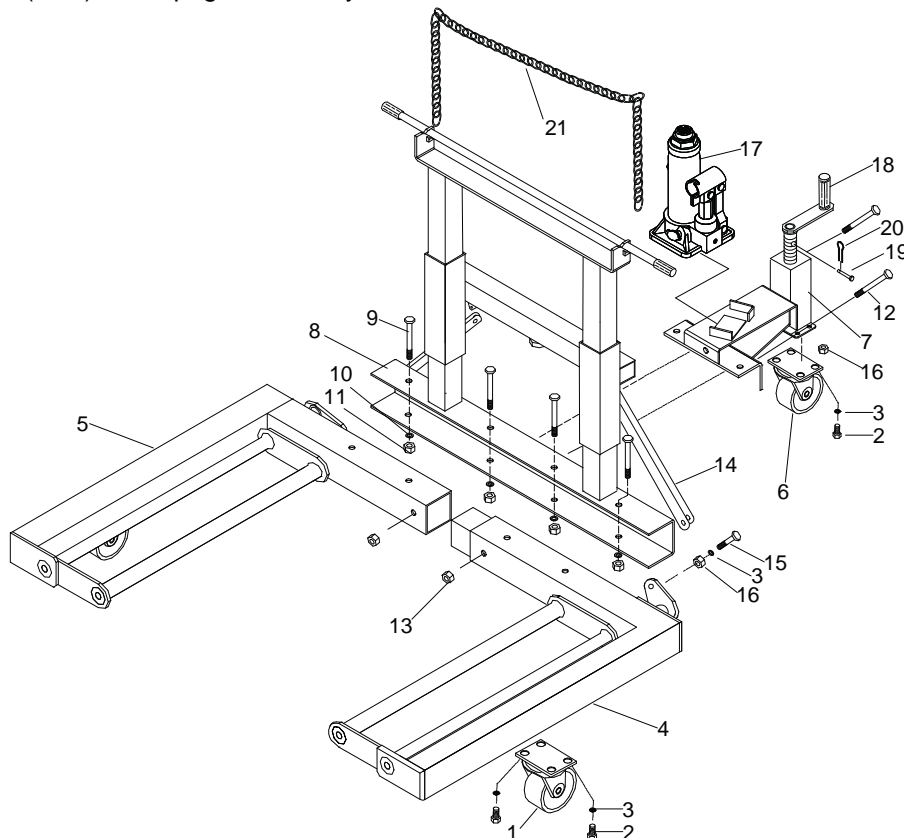

Figure 3- Assembly Drawing for model ATD-7227

## HOW TO USE

1. Set emergency brake, chock tires of diagonally opposed wheel(s) in both directions AND take every precaution necessary to ensure set up is stable and prevent inadvertent vehicle movement.
2. When tire & wheel assembly are ready to remove, position wheel dolly to accept tire & wheel assembly and secure load with restraint.
3. Use jack handle to turn release valve clockwise until tight. DO NOT OVERTIGHTEN. Insert jack handle into handle sleeve of hydraulic unit and pump until lifting arms reach desired height.

**Note:** Do not use wheel dolly to free a seized up wheel assembly. For typical practice of taking out a seized up wheel assembly, a long metal bar can be used to pry the wheel assembly from the stuck wheel axle. If in doubt, always follow vehicle's manufacturer manual on how to remove tire & wheel assembly.

4. Use load leveler to adjust the angle.
5. Carefully move loaded wheel dolly away from hub.
6. To install, reverse order.

**Note:** Before moving loaded wheel dolly, always secure the load with provided chain.

## MAINTENANCE

**Important:** Use only a good grade hydraulic jack oil. Avoid mixing different types of fluid and NEVER use brake fluid, turbine oil, transmission fluid, motor oil or glycerin. Improper fluid can cause premature failure of the jack and the potential for sudden and immediate loss of load. We recommend Mobil DTE 13M or equivalent.

### Adding Oil:

1. With saddle fully lowered and pump piston fully depressed, adjust wheel dolly to level position. Remove oil filler plug.
2. Fill until oil is level with the filler plug hole, reinstall oil filler plug.

### Changing Oil:

For best performance, replace the fluid at least once per year.

1. With saddle fully lowered and pump piston fully depressed, remove jack from leveler assembly, then remove the oil filler plug.
2. Lay the jack on its side and drain the fluid into a suitable container.

**Note:** Dispose of hydraulic fluid in accordance with local regulations.

3. Fill with good quality hydraulic jack oil. Reinstall oil filler plug.

### Lubrication

A coating of light lubricating oil to pivot points, axles and hinges will help to prevent rust and assure that casters and pump assemblies move freely.

### Cleaning

Periodically check the pump piston and ram for signs if rust or corrosion. Clean as needed and wipe with a clean, oil soaked rag.

**Note:** Never use sandpaper or abrasive material on these surfaces!

### Storage

When not in use, store the unit with pump piston and ram fully retracted.

## TROUBLESHOOTING

Symptom	Possible Causes	Corrective Action
Hydraulic unit will not lift load	<ul style="list-style-type: none"> <li>• Release valve not tightly closed</li> <li>• Overload condition</li> </ul>	<ul style="list-style-type: none"> <li>• Ensure release valve tightly closed</li> <li>• Remedy overload condition</li> </ul>
Hydraulic unit bleeds off after lift	<ul style="list-style-type: none"> <li>• Release valve not tightly closed</li> <li>• Overload condition</li> <li>• Hydraulic unit malfunction</li> </ul>	<ul style="list-style-type: none"> <li>• Ensure release valve tightly closed</li> <li>• Remedy overload condition</li> <li>• Contact Tech. Service (888) 332-6419</li> </ul>
Hydraulic unit will not lower after unloading	<ul style="list-style-type: none"> <li>• Reservoir overfilled</li> <li>• Linkages binding</li> </ul>	<ul style="list-style-type: none"> <li>• Drain fluid to proper level</li> <li>• Clean and lubricate moving parts</li> </ul>
Poor performance	<ul style="list-style-type: none"> <li>• Fluid level low</li> <li>• Air trapped in system</li> </ul>	<ul style="list-style-type: none"> <li>• Ensure proper fluid level</li> <li>• With ram fully retracted, remove oil filler plug to let pressurized air escape, then reinstall oil filler plug</li> </ul>
Will not lift to full extension	<ul style="list-style-type: none"> <li>• Fluid level low</li> </ul>	<ul style="list-style-type: none"> <li>• Ensure proper fluid level</li> </ul>

## ONE YEAR LIMITED WARRANTY

For a period of one (1) year from date of purchase, **ATD Tools, Inc.** will repair or replace, at its option, without charge, any of its products which fails due to a defect in material or workmanship, or which fails to conform to any implied warranty not excluded hereby.

Performance of any obligation under this warranty may be obtained by contacting your distributor or point of sale for further instructions. Please retain your proof of purchase, as it will be needed for any claim.

Except where such limitations and exclusions are specifically prohibited by applicable law, (1) the CONSUMER'S SOLE AND EXCLUSIVE REMEDY SHALL BE THE REPAIR OR REPLACEMENT OF DEFECTIVE PRODUCTS AS DESCRIBED ABOVE, and (2) **ATD Tools, Inc.** SHALL NOT BE LIABLE FOR ANY CONSEQUENTIAL OR INCIDENTAL DAMAGE OR LOSS WHATSOEVER, and (3) THE DURATION OF ANY AND ALL EXPRESSED AND IMPLIED WARRANTIES, INCLUDING WITHOUT LIMITATION, ANY WARRANTIES OF MERCHANTABILITY AND FITNESS FOR A PARTICULAR PURPOSE, IS LIMITED TO A PERIOD OF ONE (1) YEAR FROM DATE OF PURCHASE.

Some states do not allow limitations on how long an implied warranty lasts, so the above limitation may not apply to you. Some states do not allow the exclusion or limitation of incidental or consequential damages, so the above limitation or exclusion may not apply to you. This warranty gives you specific legal rights, and you may also have other rights which vary from state to state.

## REPLACEMENT PARTS

Available Parts: Please refer to the Parts drawing when ordering parts. Not all components of the dolly are replacement items, but are illustrated as a convenient reference of location and position in the assembly sequence. When ordering parts, give model number, part number and description below. Contact your distributor for current pricing.

Model ATD-7227

<u>Ref #</u>	<u>Part #</u>	<u>Description</u>	<u>Qty.</u>
1	B020-10000-000	Hydraulic Unit	1
2	T474-04000-000	Front Caster (3 1/2")	2
3	T590-90009-K01	Rear Caster (5")	1
4	4200-03004-000	Chain	1
—	ATD7227-L0	Label ( not shown)	1
—	ATD7227-M0	Owner's Manual	1
—	T5400S-096	Hardware Kit ( not shown)	all bolts and nuts

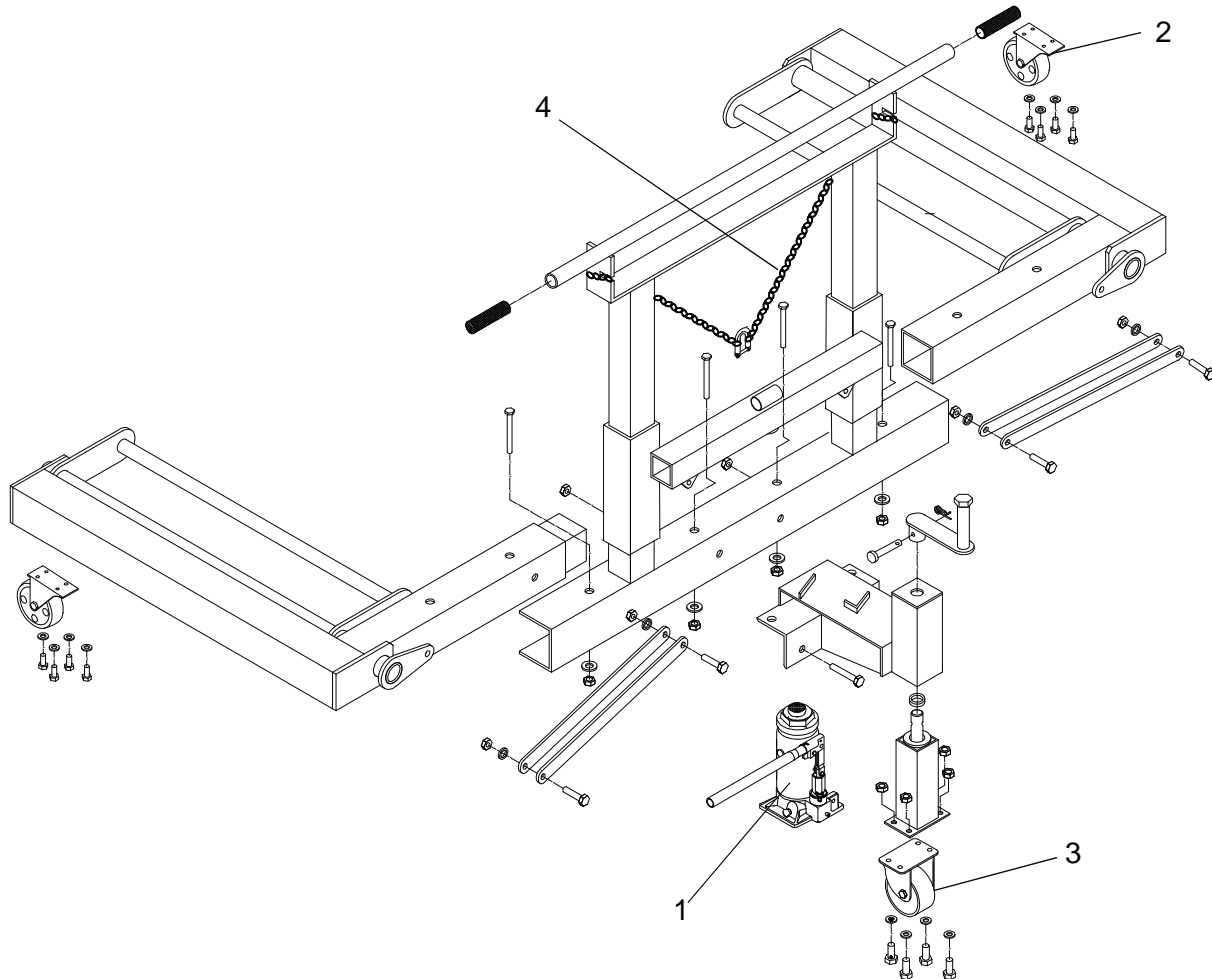

Figure 4 - Replacement Parts Illustration for model ATD-7227

# Notes

---

---

---

---

---

---

---

---

---

---

---

---

---

---

---

---

---

---

---

---

---

---

---

---



# Notes

---

---

---

---

---

---

---

---

---

---

---

---

---

---

---

---

---

---

---

---

---

---

---

---



ATD Tools, Inc.  
160 Enterprise Drive  
Wentzville, MO 63385  
[www.atdtools.com](http://www.atdtools.com)