



ATD-7227A 3/4 Ton Hydraulic Wheel Dolly Owner's Manual



Features:

- Hydraulic system actuated to provide smooth, positive power for the removal and installation of single, tandem and duplex tires and wheels
- Lift arms can be adjusted to handle different wheel combinations
- (2) Safety chains for securing loads
- Meets or exceeds ASME / PASE 2014 standards

Specifications:

- Capacity (Ton): 3/4
- Lifting Range: 2-1/4" - 11"
- Lifting Arm Dimensions: 25-1/2" x 32-7/8"
- Tilt Range: -2° to 5°
- Size: 43-1/2" L x 43" W x 34-7/8" H
- Weight: 151 lbs.



The safety alert symbol is used to alert you to potential personal injury hazards. Obey all safety messages that follow this symbol to avoid possible injury or property damage.

Read this manual and follow all Safety Rules and Operating Instructions before using this product.

SAFETY AND GENERAL INFORMATION

Save these instructions. For your safety, read and understand the information contained within. The owner and operator should have an understanding of this product and safe operating procedures before attempting to use this product. Instructions and Safety information should be conveyed in the operator's native language before use of this product is authorized. Make certain that the operator thoroughly understands the inherent dangers associated with the use and misuse of the product. If any doubt exists as to the safe and proper use of this product as outlined in this factory authorized manual, remove from service until which time it is clear.

Inspect before each use. Do not use if broken, bent, cracked or otherwise damaged parts are noted. If the dolly has been or suspected to have been subjected to a shock load, discontinue use until checked out by an authorized factory service center. Owners and operators of this dolly should be aware that the use and subsequent repair of this equipment may require special training and knowledge. It is recommended that an annual inspection be done by qualified personnel and that any missing or damaged parts, decals, warning / safety labels or signs be replaced with factory authorized replacement parts only. Any dolly that appears to be damaged in any way, is worn or operated abnormally should be removed from service immediately until such time as repairs can be made.

PRODUCT DESCRIPTION

ATD Tools Hydraulic Wheel Dolly is designed to facilitate the removal and installation of pneumatic tires and wheel assemblies found on many trucks, buses and trailers. This is **NOT** suitable for use as a wheel and tire puller. It is designed **ONLY** for use in removing up to rated capacity tire and wheel assemblies which are **not** bound and/or seized up at the brake drum or hub assemblies. This device is designed to be used in conjunction with jacks and jack stands

WARNING: NEVER load this device with more than the weight of the wheel assembly to be removed! **ENSURE** that the vehicle is securely positioned and supported by mechanical means such as a pair of appropriately rated jack stands or cribbing and blocking.

WARNING: NEVER use a wheel dolly as a wheel pulling device. Before transporting wheel assembly ensure that it is free from the hub or drum assembly and that it is secured to the wheel dolly using the provided securing means. NEVER load this device with more than the weight of the wheel assembly to be removed!

SPECIFICATIONS

Model	Capacity	Lifting Arm Dimensions	Lifting Range	Product Size (L x W x H)	Tilt Range	Weight
ATD-7227A	3/4 Ton (1500 lbs.)	25-1/2"	2-1/4" - 11"	43-1/2" x 43" x 34-7/8"	-2° - 5°	151 lbs

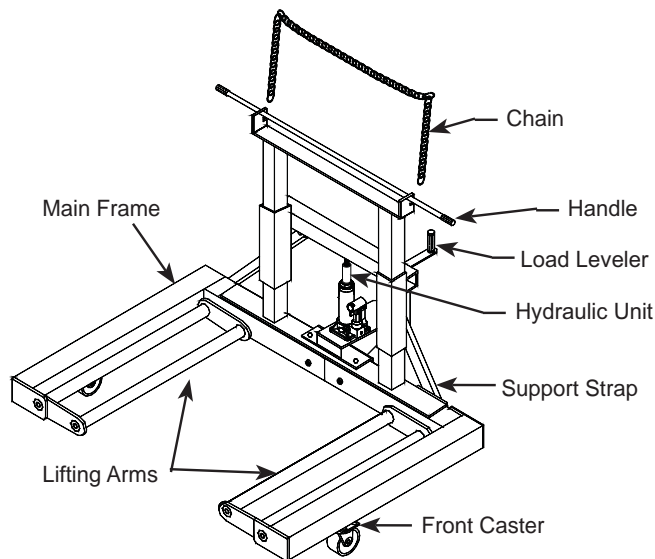

Figure 1 - ATD-7227A Wheel Dolly Components

BEFORE USE

1. Inspect before each use. Do not use if bent, broken, leaking or cracked components are noted. Ensure that casters, rollers and lifting arms move freely. Check and tighten any loose assemblies.
2. Verify that the product and the application are compatible.
3. Read, understand and follow vehicle manufacturer's recommended tire change procedures.
4. With ram lowered, locate and remove oil filler plug. This purges the hydraulic system of pressurized air trapped in reservoir. Check fluid level. Proper level is level with filler plug hole.
5. Reinstall oil filler plug.

! WARNING

- Read and understand all warnings and instructional material provided on and with this product before use.
- Do not exceed rated capacity.
- Use only on smooth, hard, level surfaces capable of sustaining the load.
- Before moving, lower the load to the lowest possible point and assure that the load is centered and secured with a load restraint device.
- Apply load as close to the vertical position of the lifting arms as possible.
- No alterations shall be made to this product.
- Failure to heed this warning may result in personal injury as well as property damage.

PREPARATION

ATD-7227A Assembly (refer to Fig. 2 & 4)

1. Attach 3 1/2" caster (1) to left and right main frame (2 & 3) with bolts & washers (4).
2. Attach 5" caster (5) to rear support (6), with bolts, washers & nuts (7).
3. Insert left main frame (2) into right main frame (3).
4. Attach upright (8) and rear support (6) into the main frame assembly (2 & 3) with two bolts & nuts (9) and four bolts, washers & nuts (10).
5. Attach support straps (11) to the mounting ears of upright and main frame with bolts, washers and nuts (12).
6. Attach hydraulic unit (13) onto the upright assembly (8).
7. Insert load leveler handle (14) to rear support (6) with pin and cotter pin (15 & 16).
8. Attach the chain (17) onto upright assembly.

Size of Hardware Kits		Qty	
4	bolt	M8x16	8
	lock washer	M8	8
7	bolt	M8x16	4
	lock washer	M8	4
	nut	M8	4
9	bolt	M12x100	2
	nut	M12	2
10	bolt	M14x110	4
	washer	M14	4
	nut	M14	4
12	bolt	M8x34	4
	lock washer	M8	4
	nut	M8	4

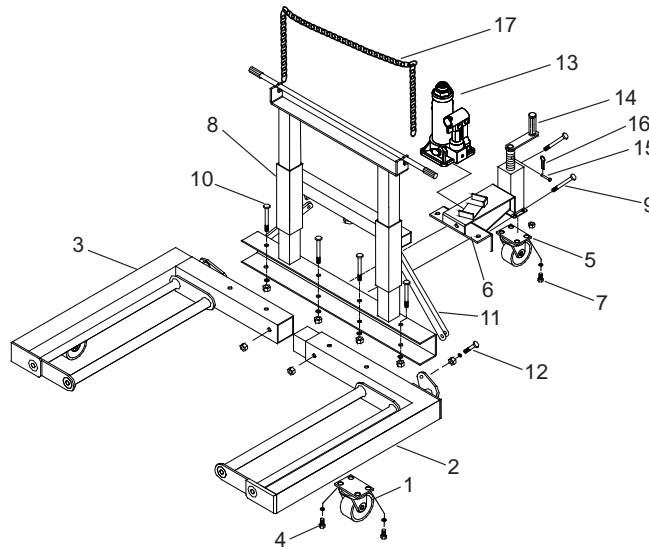

Figure 2 - Assembly Illustration for Model ATD-7227A

! WARNING



To avoid crushing and related injuries and or property damage:

- **Read, understand and follow** all printed materials provided with and on this wheel dolly
- Do not exceed rated capacity.
- **Before** positioning wheel dolly, **ensure** that the vehicle is securely positioned and supported by mechanical means such as a pair of appropriately rated jack stands or cribbing and blocking.
- Use only on smooth, hard and level surfaces capable of sustaining the load.
- **Chock** each unlifted wheel assembly in both directions.
- **Be alert** and **sober** when using this product! **Never** operate this equipment when under the influence of drugs or alcohol.
- Before moving, lower the load to the lowest possible point and assure that the load is centered and secured with a load restraint device.
- Only attachments and/or adapters supplied by the manufacturer shall be used.
- No alterations shall be made to this product.
- Never use hydraulic unit (jack) as a stand alone device.
- Apply load as close to the vertical position of the lifting member as possible.

OPERATION

Vehicle Preparation

1. Place vehicle on a hard, level surface, such as reinforced concrete, large enough to accommodate vehicle, jacks, jack stands, and wheel dolly.
2. Set the emergency brake unless the rear drum, tire and wheel are all to be removed as an assembly.
3. Chock all unlifted tires in both directions AND take every precaution necessary to ensure the set up is stable and will prevent all inadvertent vehicle movement.

Raising The Lifting Arms

1. Close release valve by turning it with slotted portion of handle clockwise until firm resistance is felt to further thread engagement.

! WARNING: Follow the vehicle manufacturers recommended removal and installation procedures for tire, wheel, hub, or axle assemblies as needed! **DO NOT** remove more than is recommended by the vehicle manufacturer!

2. After the tire, wheel assembly has been loosened from the hub or axle and is ready to be removed, position the dolly under the assembly to be removed. Pump until load reaches desired height. Adjust lift arm tilt such that the tire, wheel assembly will nest securely between the lift arms without falling forward (toward the front wheels).

Loading the Wheel Dolly

! WARNING: NEVER load this device with more than the weight of the wheel assembly to be removed! **ENSURE** that the vehicle is securely positioned and supported by **mechanical means** such as **a pair of appropriately rated jack stands or cribbing and blocking**.

! WARNING: NEVER use a wheel dolly as a **wheel pulling** device. Before transporting wheel assembly. **! Ensure** that it is free from the hub or drum assembly and that it is secured to the wheel dolly using the provided restraint device.

When the weight of the loosened tire, wheel assembly is supported by the wheel dolly, Carefully roll the wheel dolly away from the drum or axle. When the assembly is clear, immediately secure the tire/wheel assembly with the provided chains.

Lowering

Engage and slowly turn the release valve counterclockwise, but never more than 1 full turn.

Transporting Loaded Wheel Dolly

1. Ensure that wheel assembly is secured to the wheel dolly by means of the provided chains.
2. When wheel assembly has cleared the hub or the axle, lower the lift arms to the lowest position that will still allow wheel dolly wheel and caster movement.
3. Push or pull to desired location.

! WARNING: Follow the vehicle manufacturers recommended removal and installation procedures for tire, wheel, hub, or axle assemblies as needed!

! WARNING: If the operating handle is worn, operates abnormally, or will not positively engage the release valve, immediately discontinue use of the jack until a replacement handle assembly can be acquired.

Transporting Loaded Wheel Dolly

1. Ensure that wheel assembly is secured to the wheel dolly by means of the provided chains.
2. When wheel assembly has cleared the hub or the axle, lower the lift arms to the lowest position that will still allow wheel dolly wheel and caster movement.
3. Push or pull to desired location.

⚠ WARNING: Follow the vehicle manufacturers recommended removal and installation procedures for tire, wheel, hub, or axle assemblies as needed!

⚠ WARNING: If the operating handle is worn, operates abnormally, or will not positively engage the release valve, immediately discontinue use of the jack until a replacement handle assembly can be acquired.

⚠ WARNING: Use **only** premium hydraulic jack oil or equivalent hydraulic jack oil. Improper fluid can cause premature failure of the jack and the potential for sudden and immediate loss of load.

MAINTENANCE

Adding Oil in Hydraulic Unit

1. With saddle fully lowered set jack in its upright, level position. Locate and remove oil filler plug.
2. Fill with oil even with the bottom of oil filler plug hole. Reinstall the oil filler plug.

Changing Oil in Hydraulic Unit

For best performance and longest life, replace the complete fluid supply at least once per year.

1. Remove hydraulic unit from wheel dolly. Set hydraulic unit upright on a hard, level surface.
2. With saddle fully lowered, remove the oil filler plug.
3. Lay the jack on its side and drain the fluid into a suitable container.

Note: Dispose of hydraulic fluid in accordance with local regulations.

4. Fill with oil even with the bottom of oil filler plug hole. Reinstall the oil filler plug.
5. Install hydraulic unit back to the wheel dolly.
6. Perform Bleeding/Venting Trapped Air procedure.

Lubrication

A periodic coating of light lubricating oil to wheel dolly and hydraulic unit pivot points will help to ensure that all moving parts function smoothly.

Note: Never apply oil to the saddle.

Storage

Store the hydraulic unit with the pump piston, ram plunger, and saddle fully lowered and the release valve open, but never more than 1 turn. This will help prevent rust and corrosion to those critical surfaces.

Cleaning

Periodically check the hydraulic unit pump piston and ram for signs of rust or corrosion. Clean as needed and wipe with an oily cloth.

Note: Never use sandpaper or abrasive material on these surfaces.

TROUBLESHOOTING

Symptom	Possible Causes	Corrective Action
Hydraulic unit will not lift load	• Release valve not tightly closed	• Ensure release valve tightly closed • Remedy overload condition
Hydraulic unit bleeds off after lift	• Release valve not tightly closed • Overload condition	• Ensure release valve tightly closed • Remedy overload condition • Contact ATD Tools Tech. Service
Hydraulic unit will not lower after unloading	• Reservoir overfilled • Linkages binding	• Drain fluid to proper level • Clean and lubricate moving parts
Poor performance	• Fluid level low • Air trapped in system	• Ensure proper fluid level • With ram fully retracted, remove oil filler plug to let pressurized air escape, then reinstall oil filler plug
Will not lift to full extension	• Fluid level low	• Ensure proper fluid level

REPLACEMENT PARTS

Available Parts: Please refer to the Parts drawing when ordering parts. Not all components of the dolly are replacement items, but are illustrated as a convenient reference of location and position in the assembly sequence. When ordering parts, give model number, serial number and description below.

Model: ATD-7227A

Item	Part No.	Description	Qty
1	T474-04000-000	Front Caster, 31/2"	2
2	*	Spring Washer	16
3	*	Bolt, M8x16	12
4	T590-03000-000	L. Main Frame	1
5	*	Hex Nut M8	8
6	T590-00001-000	Lifting Strap	4
7	*	Bolt M8x34	4
8	T590-90009-K01	Rear Caster 5"	1
9	T590-04000-000	Rear Support Lifter	1
10	*	Bolt M12x100	2
11	*(5602-00035-000)	Bearing	1
12	T590-05000-000	Rear Support Frame	1
13	*(5403-06035-000)	Pin Ø6x35	1
14	T590-02000-000	Load Leveler Assy.	1

Item	Part No.	Description	Qty
15	*(5405-02018-000)	Snap pin	1
16	T590-06000-000	R. Main Frame	1
17	G933-00001-000	Handle Grip	2
18	T590-01000-000	Post Assy	1
19	T590-07000-000	Chain	1
20	*	Bolt M14x110	4
21	*	Spring Washer	4
22	*	Hex Nut M14	4
23	10045C	Hydraulic Unit, 4T	1
24	*	Hex Nut M12	2
25	F36100-0001	Oil Filler Plug	1
26	B20207-0002	Pump Handle	1
(*)	T590-09000-000	Hardware Kit	-

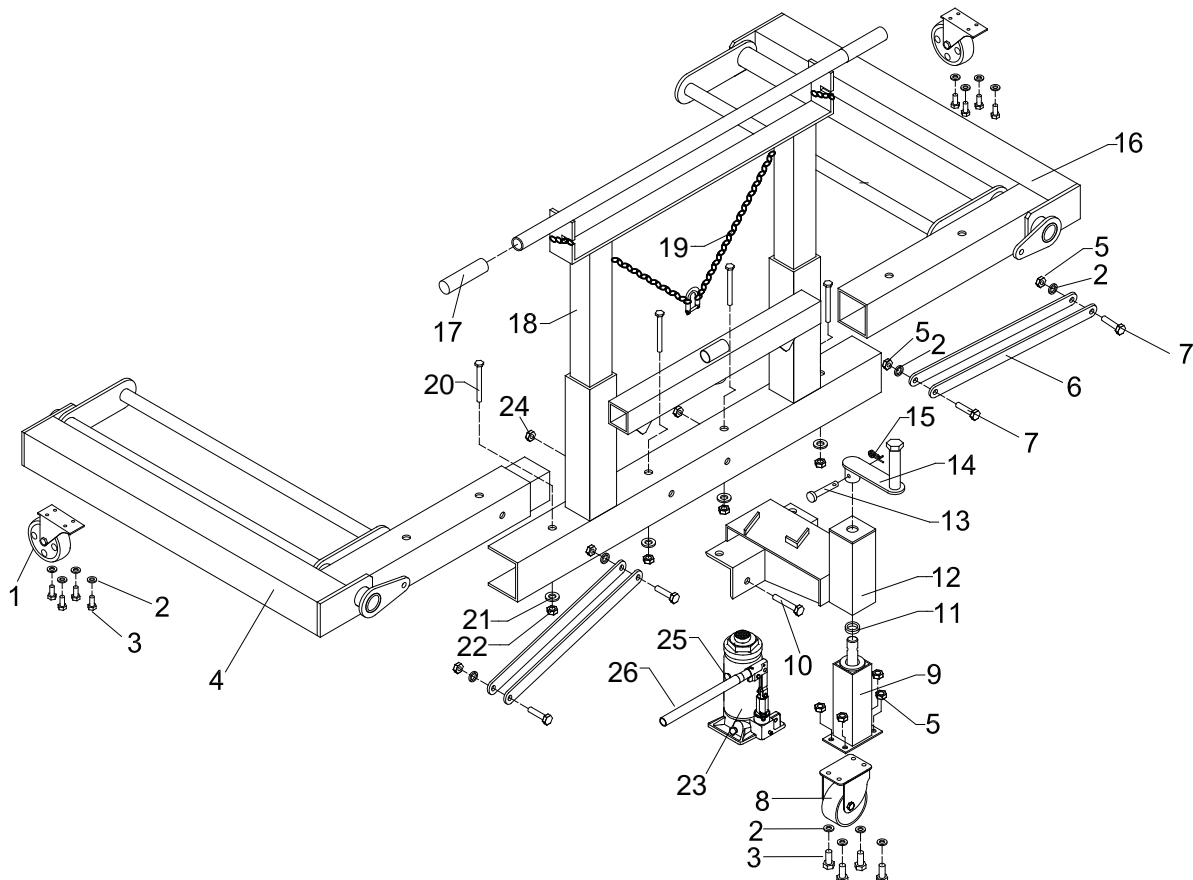

Figure 3 - Replacement Parts Illustration for Model ATD-7227A



ATD[®]

WARRANTY

1 YEAR LIMITED WARRANTY

THIS WARRANTY AND CONFIRMED RECEIPT(S) SHOULD BE RETAINED BY THE CUSTOMER AT ALL TIMES

PURCHASED FROM: _____

DATE PURCHASED: _____

INVOICE/RECEIPT NUMBER: _____

Your ATD-XXXX is warranted for a period of 12 months from the original purchase date.

For a period of one (1) year from your purchase date, ATD Tools, Inc. will repair or replace (at its option) without charge, your ATD product if it was purchased new and the product has failed due to a defect in material or workmanship which you experienced during normal use of the product. This limited warranty is your exclusive remedy.

To access the benefits of this warranty, contact your supplier, or point of sale directly. You may be advised to return the product under warranty, freight prepaid, to your supplier for warranty determination.

If this ATD product is altered, abused, misused, modified, or undergoes service by an unauthorized technician, your warranty will be void. We are not responsible for damage to ornamental designs you place on this ATD product and such ornamentation should not cover any warnings or instructions or they may void the warranty. This warranty does not cover scratches, superficial dents, and other abrasions to the paint finish that occur under normal use. It also does not cover normal wear items such as but not limited to brushes, batteries, drill bits, drill chucks, pads or blades.

Subject to the law in your state:

- (1) Your sole and exclusive remedy is repair or replacement of the defective product as described above.
- (2) ATD is not liable for any incidental damages, including but not limited to, lost profits and unforeseeable consequences.
- (3) The repair and replacement of this product under the express limited warranty described above is your exclusive remedy and is provided in lieu of all other warranties, express or implied. All other warranties, including implied warranties and warranties of merchantability or fitness for a particular purpose are disclaimed and, if disclaimer is prohibited, these warranties are limited to one year from your date of purchase of this product.

Some states' laws do not allow limited durations on certain implied warranties and some states' laws do not allow limitations on incidental or consequential damages. You should consult the law in your state to determine how your rights may vary.

[Affix receipt or invoice here for safe keeping]