

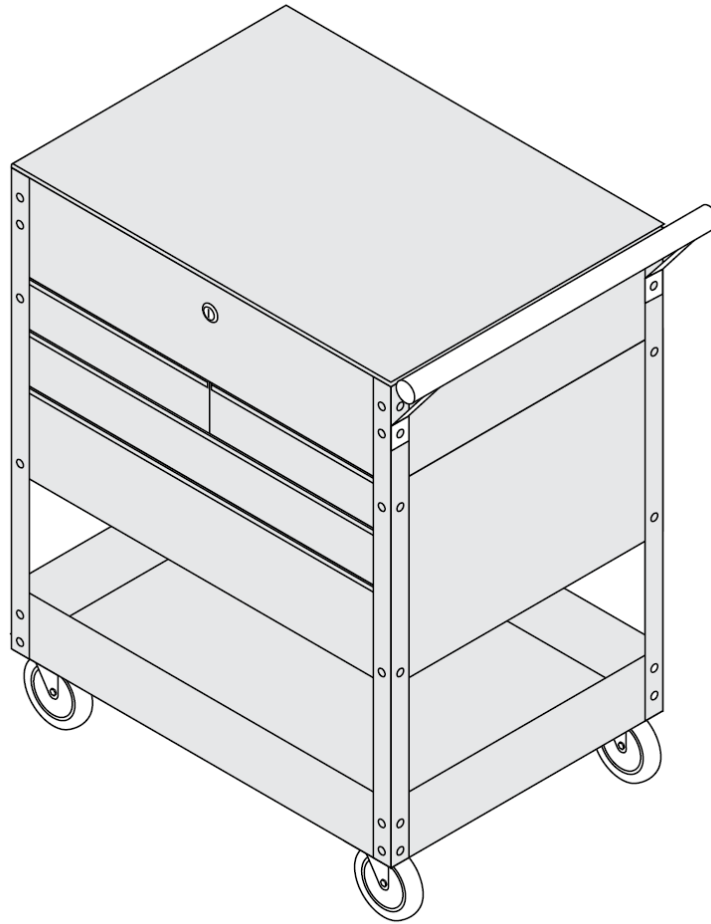

ATD7045 (RED), ATD7046 (BLACK), ATD7047 (BLUE) SERVICE CART WITH LOCKING TOP & DRAWERS







FEATURES:

- Heavy duty all steel construction
- Quality ball bearing slides for smooth & easy opening/closing
- Gas struts to keep lid open
- Locking screwdriver & pry bar holder
- Professional barrel key lock
- Oil resistant heavy-duty 5" x 1 1/4" casters, 2 locking/2 non-locking
- Convenient handle can be installed on either end for easy maneuvering

SPECIFICATIONS:

- Weight Capacity: 500 Pounds
- Overall Dimensions: 30-7/8" wide X 20-1/2" deep X 40-1/2" high
- Lockable Capacity: 8,645 Cubic Inches
- Top Bin: 29-1/8" Wide x 19" Deep x 6" High (3,320 Cubic Inches)
- Top Drawers (2): 12-1/4" Wide x 17-1/2" Deep x 3" High (643 Cubic Inches Each)
- Third Drawer: 25-5/8" Wide x 17-1/2" Deep x 3" High (1,348 Cubic Inches)
- Fourth Drawer: 25-5/8" Wide x 17-1/2" Deep x 6" High (2,691 Cubic Inches)
- Bottom Tray: 29-3/4" Wide x 19-1/8" Deep x 3" High (10-3/8" Between Bottom Tray & Fourth Drawer)
- Total Weight: 145 Pounds

TOOLS NEEDED					
	Tabletop or workbench*	2 People	13mm & 14mm Wrench	Ratchet with 13mm socket	Adjustable Wrench

ASSEMBLY INSTRUCTIONS

Step 1: Assembly Preparation

Remove all contents from box. Reference the parts list to make sure you have all the parts.

CAUTION

Verify your tabletop or workbench can support 150 lbs. (68 kg.). Failure to follow this warning could result in damage to property or personal injury.

NOTE

Cover table or workbench to prevent any damage to surface.

Step 2: Side Panels

Lay two side supports (I) down on the table top and attach side panel (K) as shown in figure 2. Repeat with other two supports (I) and side panel (K). **NOTE:** Side supports are marked with UP label to indicate which side is up.

Step 3: Attaching Casters

Turn bottom tray (B) upside down. Align holes in locking and non-locking casters (F & G) with matching holes in the bottom tray as shown in figure 3a. Attach 14mm bolt, lock washer and 13mm nuts from caster bolt kit (C) and hand tighten.

NOTE: Ensure that both locking casters are on same end of the cast. We suggest same side as handle.

Step 4: Aligning the Side Supports

Make sure the drawer assembly lid is open. Place side supports (I) and attached side panels (K) onto drawer assembly (A) and bottom of tray (B) as shown in figure 4. Repeat on opposite side of service cart. Hand tighten so all holes will line up.

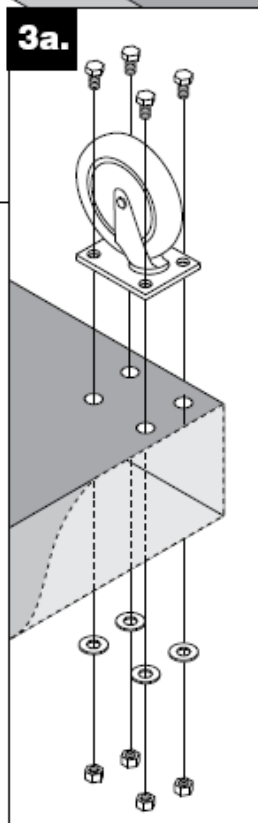
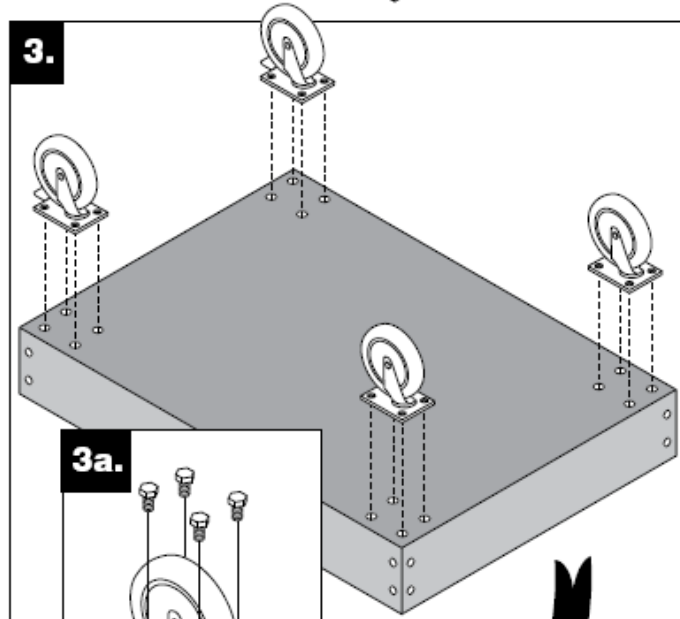
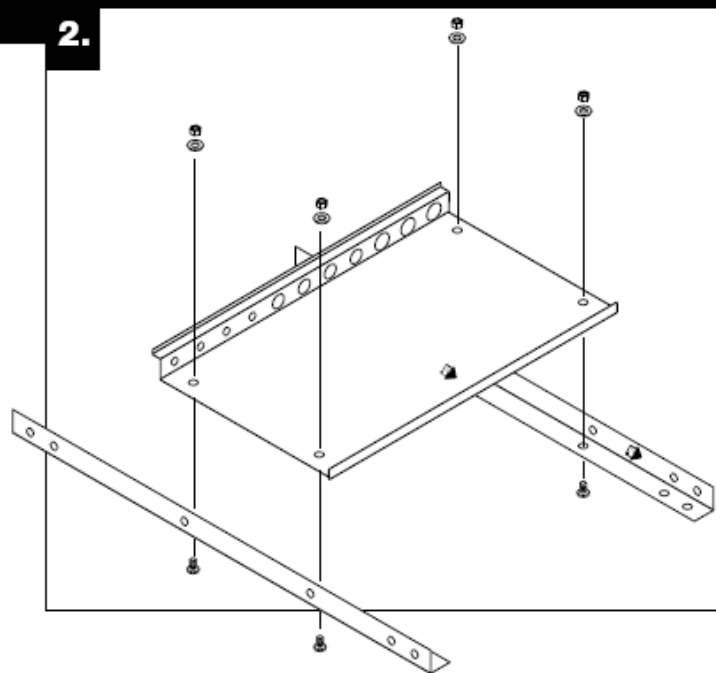
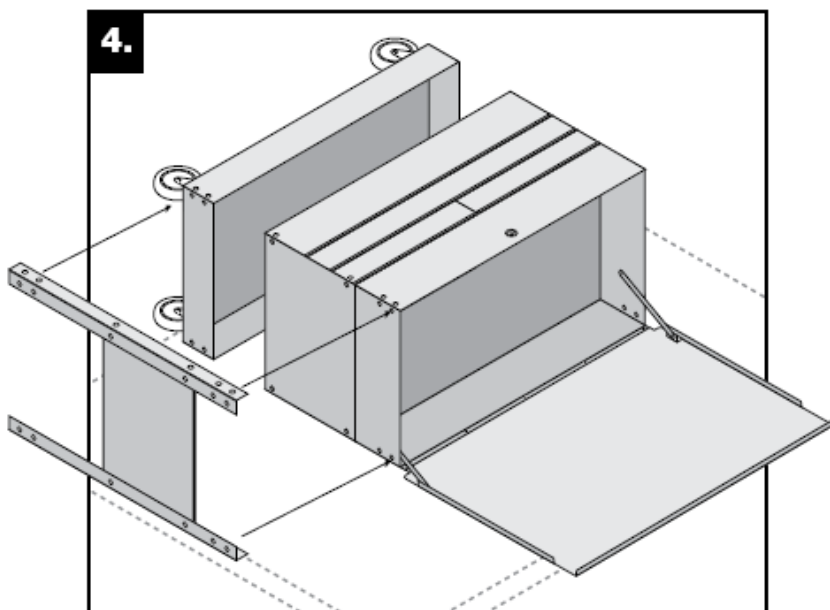

ASSEMBLY INSTRUCTIONS

Step 5: Attaching Bottom Tray and Drawer Assembly to Side Supports

Once handle is attached, align holes in side supports (I) with matching holes in bottom tray (A) and drawer assembly (B) as shown in figure 5. Insert side support bolts (D) through side supports and into bottom tray and/or drawer assembly and secure from the inside with side support washers and nuts until all side holes have been attached and hand tightened.

Step 6: Attaching the Handles

Align the other two side supports (I) with the front corners of the bottom tray and drawer assembly and let them rest on top as shown in figure 6. Align the hole on the handle (H) with the second hole down on the drawer assembly and (un-attached) side support as shown in figure 6. Insert handle bolts (E) through handle, through the side support, and into the drawer assembly as shown in figure 6. Secure with washer and nut from handle bolt kit (E) and hand tighten.

Step 7: Securing Side Supports

Using two people, turn the cart upright. Continue to bolt through aligned holes in the front and back of the cart with the side support bolts, washers, and nuts (D) as shown in figure 7. Hand tighten. ALL holes should now be aligned and secured.

Step 8: Tightening Bolts (not shown)

Use a 13mm wrench or a ratchet with 13mm socket or adjustable wrench to tighten all bolts. Be sure to apply pressure to bolt head while tightening to keep in correct position. Once all bolts are tightened, your cart is complete. See page 4 for parts breakdown.

5.

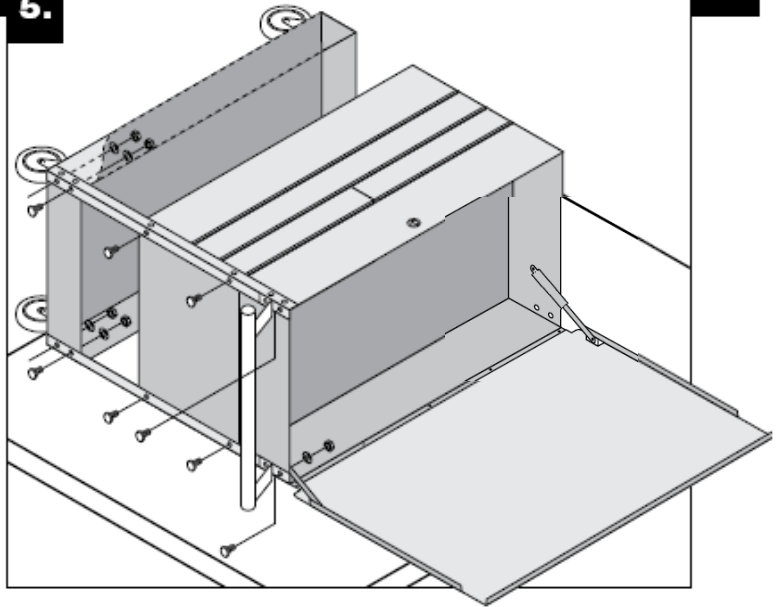

6.

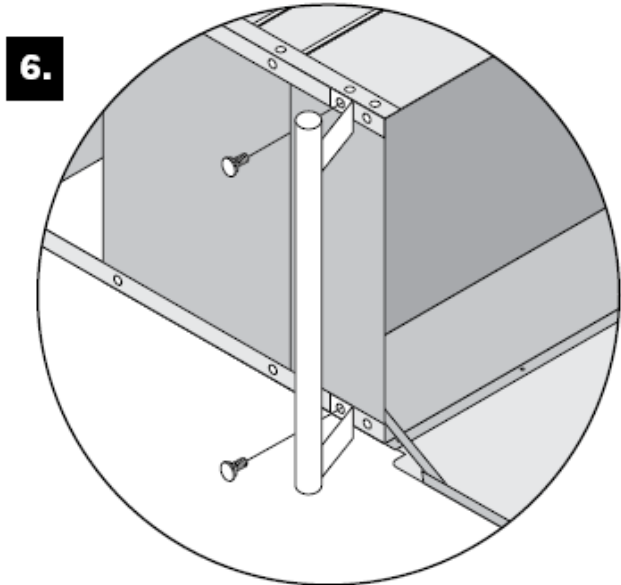

7.

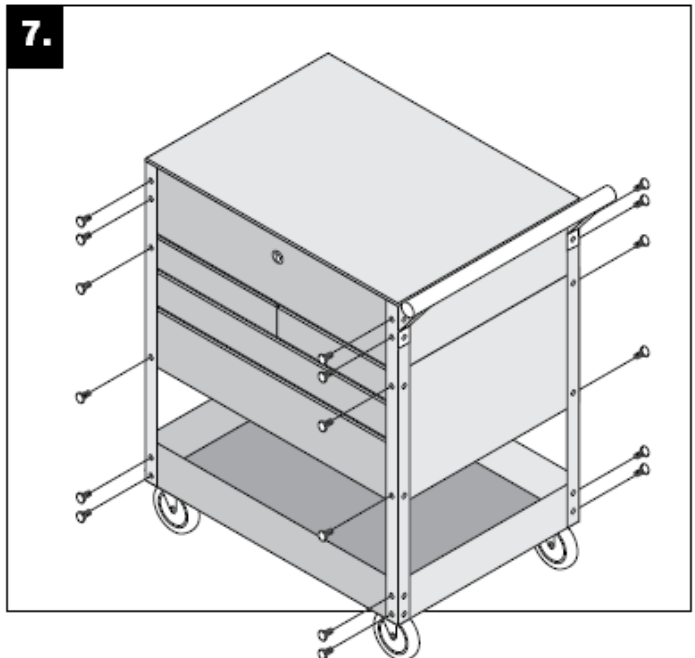

PARTS LIST

**ATD-7045
ATD-7046
ATD-7047**

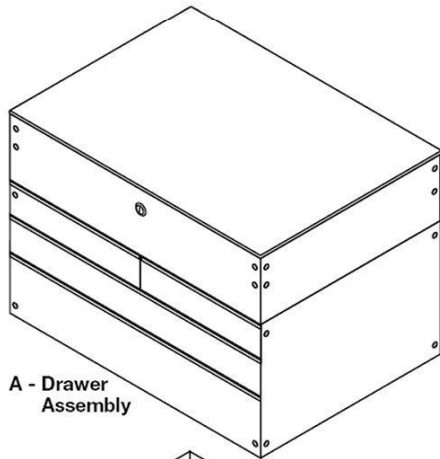

A - Drawer Assembly

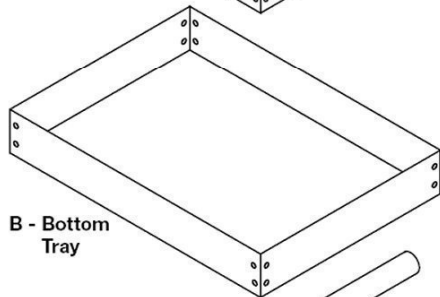

B - Bottom Tray

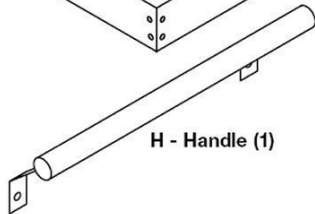

H - Handle (1)



**C - Caster Bolt Kit (16) ea:
M8x16mm Bolt
Spring Washers
M8 Nut**



**D - Side Support Bolt Kit (44) ea:
M8x12mm Ball Type Screws
Spring Washers
M8 Nuts**



**E - Handle Bolt Kit (2) ea:
M8x16mm Ball Type Screws
Spring Washers
M8 Nuts**

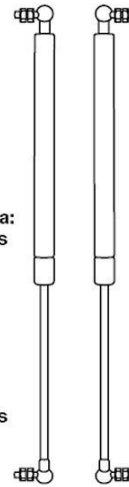

L - Gas Pistons (2)

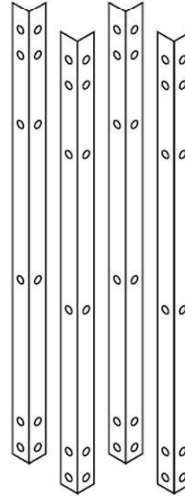

I - Side Supports (4)

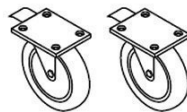

F - Locking Casters (2)

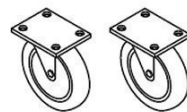

G - Non-Locking Casters (2)



**J - Lock & Keys
(Attached to Drawer)**

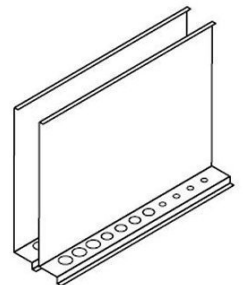

K - Side Panels (2)

ITEM#	ORDERING PART#	PART DESCRIPTION
A*	PRT7045-01	DRAWER ASSY (RED)
A*	PRT7046-01	DRAWER ASSY (BLACK)
A*	PRT7047-01	DRAWER ASSY (BLUE)
B*	PRT7045-02	BOTTOM TRAY (RED)
B*	PRT7046-02	BOTTOM TRAY (BLACK)
B*	PRT7047-02	BOTTOM TRAY (BLUE)
C	PRT7045-03	CASTER BOLT KIT
D	PRT7045-04	SIDE SUPPORT BOLT KIT
E	PRT7045-05	HANDLE BOLT KIT
F	PRT7045-06	LOCKING CASTERS (EACH)
G	PRT7045-07	NON-LOCKING CASTERS (EACH)

ITEM#	ORDERING PART#	PART DESCRIPTION
H	PRT7045-08	HANDLE
I*	PRT7045-09	SIDE SUPPORTS (RED) (EACH)
I*	PRT7046-09	SIDE SUPPORTS (BLACK) (EACH)
I*	PRT7047-09	SIDE SUPPORTS (BLUE) (EACH)
J	PRT7045-10	LOCK AND KEY ASSY
K*	PRT7045-11	SIDE PANELS (RED) (SET/2)
K*	PRT7046-11	SIDE PANELS (BLACK) (SET/2)
K*	PRT7047-11	SIDE PANELS (BLUE) (SET/2)
L	PRT7045-12	GAS PISTONS (EACH)
N/S	PRT7045-13	4 KEYED ALIKE LOCK AND KEY ASSY
N/S	PRT7045-14	DRAWER SLIDES (PAIR) WITH RIVETS

* - PART NUMBER INDICATES COLOR