



## ATD-7041 MIG Welding Cart



### Features:

- Heavy-duty steel construction
- (2) 5-3/8" rubber wheels & (2) 2-1/2" swivel casters
- 17-3/8" x 10-3/8" top shelf
- (2) storage shelves for accessories
- Built-in cylinder rack with safety chain
- Cable holders for torch and ground cables

### Specifications:

- Height: 24-3/4" Tall
- Weight: 19.8 lbs.
- Weight Capacity: 110 lbs.



**WARNING**



**WARNING:** This product may contain chemicals, including lead, known to the State of California to cause cancer, birth defects or other reproductive harm. *Wash hands after handling.*

Made in China to ATD Tools, Inc. Specifications  
Visit us at [www.atdtools.com](http://www.atdtools.com)

ATD7041\_rev\_0617

## WARNINGS and CAUTIONS

### PLEASE READ CAREFULLY TO AVOID UNNECESSARY INJURY

- Your ATD-7041 Mig Welding Cart is designed to carry one gas cylinder for use with mig welding only.
- Use caution when handling compressed gas cylinders and use only in upright position.
- Use provided chains and secure cylinder at the top and the bottom of the cart as tightly as possible.
- Your ATD-7041 Mig Welding Cart is designed to roll easily on flat surfaces and should not be used on inclined or uneven surfaces.
- Use caution when moving the cart as the weight of welder will cause the cart to be top heavy.
- Do not pull cart by welder leads as this could cause cart to tip over.
- Do not attempt to weld to cylinder and do not fasten ground leads to the welding cart, thus completing the circuit, which could cause mig gun to arc unexpectedly.
- Failure to follow precautions and use common sense could cause serious injury.



**NOTE:** The warnings and cautions discussed in this instruction manual cannot cover all possible conditions and situations that may occur. It must be understood by the operator that common sense and caution are factors which cannot be built into this product, but must be supplied by the operator.

## ASSEMBLY

1. Slide axle through support tube on bottom of shelf (#1). Slip washer over both ends of axle, fit wheels onto axle and insert cotter pins.
2. Install casters to front of shelf(#1) using 4 hex head screws and washers to one side of shelf and 4 lock washers and hex nuts to others side of shelf. **Finger tighten all screws and nuts until complete.**
3. Add vertical support (#2) to bottom of shelf (#1). Fasten through center hole of vertical support first. Then fasten through side holes in bottom of vertical support.
4. Fasten side support rails (#3) to bottom shelf. Add center shelf (#4) with flanges up. Start by fastening center hole towards rear of shelf then side holes in rear of shelf, finally front side holes to side support rails.
5. Fasten top shelf (#5) in similar fashion, but include brackets (#6) for cord storage to top front holes in side support rails. Now tighten all fasteners.



# ATD-7041

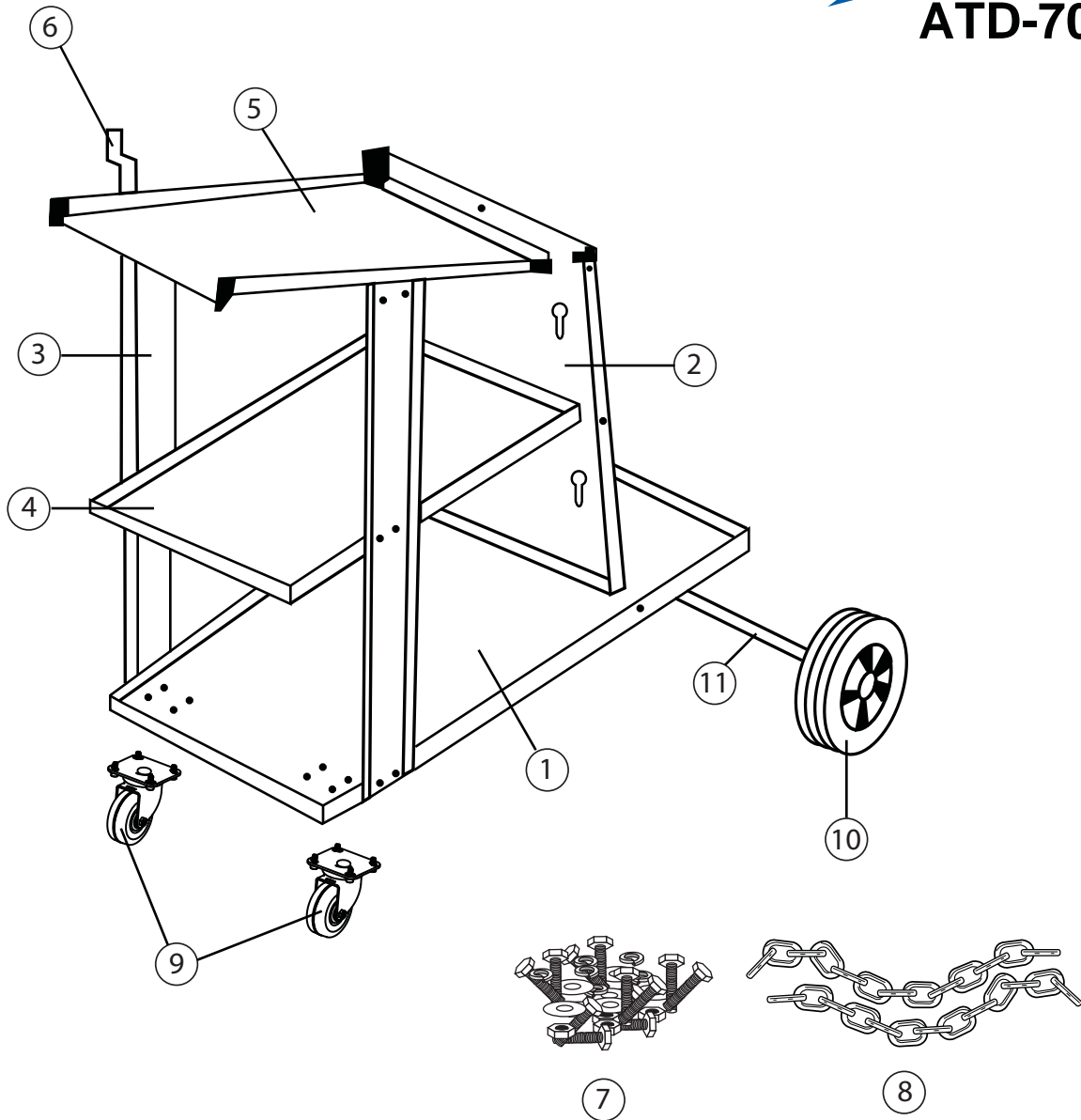

ITEM#	ORDERING PART#	DESCRIPTION
1	PRT7041-01	BOTTOM SHELF
2	PRT7041-02	VERTICAL SUPP VERTICAL SUPPORT PANEL
3	PRT7041-03	SIDE SUPPORT RAIL
4	PRT7041-04	CENTER SHELF (FOUR SIDES FLANGED UPWARD)
5	PRT7041-05	TOP SHELF (THREE SIDES FLANGED UPWARD )
6	PRT7041-06	BRACKET
7	PRT7041-07	HEX SCREWS, NUTS, WASHERS, LOCK WASHERS
8	PRT7041-08	CHAIN
9	PRT7041-09	SMALL CASTER
10	PRT7041-10	LARGE WHEEL
11	PRT7041-11	AXLE



## WARRANTY

### 1 YEAR LIMITED WARRANTY

THIS WARRANTY AND CONFIRMED RECEIPT(S) SHOULD BE RETAINED BY THE CUSTOMER AT ALL TIMES

PURCHASED FROM: \_\_\_\_\_

DATE PURCHASED: \_\_\_\_\_

INVOICE/RECEIPT NUMBER: \_\_\_\_\_

Your ATD-7041 is warranted for a period of 12 months from the original purchase date.

For a period of one (1) year from your purchase date, ATD Tools Inc. will repair or replace (at its option) without charge, your ATD product if it was purchased new and the product has failed due to a defect in material or workmanship which you experienced during normal use of the product. This limited warranty is your exclusive remedy.

To access the benefits of this warranty, contact your supplier, or point of sale directly. You may be advised to return the product under warranty, freight prepaid, to your supplier for warranty determination.

If this ATD product is altered, abused, misused, modified, or undergoes service by an unauthorized technician, your warranty will be void. We are not responsible for damage to ornamental designs you place on this ATD product and such ornamentation should not cover any warnings or instructions or they may void the warranty. This warranty does not cover scratches, superficial dents, and other abrasions to the paint finish that occur under normal use. It also does not cover normal wear items such as but not limited to brushes, batteries, drill bits, drill chucks, pads or blades.

Subject to the law in your state:

- (1) Your sole and exclusive remedy is repair or replacement of the defective product as described above.
- (2) ATD is not liable for any incidental damages, including but not limited to, lost profits and unforeseeable consequences.
- (3) The repair and replacement of this product under the express limited warranty described above is your exclusive remedy and is provided in lieu of all other warranties, express or implied. All other warranties, including implied warranties and warranties of merchantability or fitness for a particular purpose are disclaimed and, if disclaimer is prohibited, these warranties are limited to one year from your date of purchase of this product.

Some states' laws do not allow limited durations on certain implied warranties and some states' laws do not allow limitations on incidental or consequential damages. You should consult the law in your state to determine how your rights may vary.

[Affix receipt or invoice here for safe keeping]