



ATD-70360
1200 lbs. Heavy-Duty Workbench
Owner's Manual



Features:

- Powder coated heavy-gauge steel construction
- Raised lip around table top edge contains loose parts
- Includes full length bottom shelf for additional storage
- Adjustable foot pads for placement on slightly uneven surfaces

Specifications:

- Dimensions: 60" W x 36" H x 31" D
- Weight: 140 lbs.
- Capacity: 1,200 lbs.

CAUTION

Read and follow all assembly instructions and safety rules before using this product. Retain this manual for future reference.

RECOMMENDED TOOLS (NOT INCLUDED)

- Adjustable wrench
- Socket wrench and 10mm and 12mm sockets
- 3" socket extension
- Square or level
- Rubber mallet

HARDWARE INCLUDED

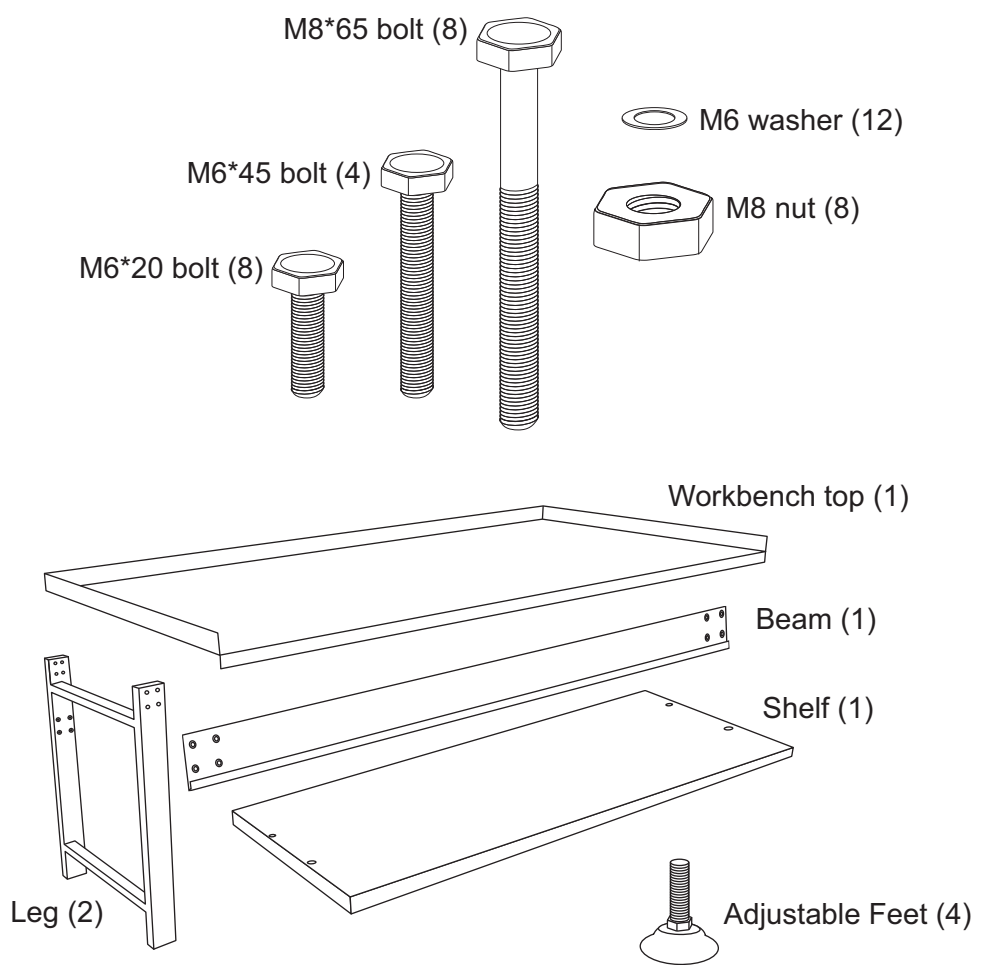

SAFETY WARNINGS AND CAUTIONS

- Use appropriate safety equipment when using tools. Failure to use appropriate equipment may cause injury or product damage.
- **DO NOT** stand on this product.
- **DO NOT** mount this workbench to a truck bed or any other vehicle or moving object. This may result in injury or damage to the product.
- **DO NOT** alter this product. (Examples: do not weld accessories to this table or attach electrical equipment. This may cause injury or damage to the product.)
- Keep workbench on level surfaces. The workbench may tip if moved or stored on an unstable surface, resulting in injury or damage to the product.
- Maximum weight limit: 1200 lbs. Exceeding this weight limit may cause structural failure and collapse resulting in injury or damage to the product.

ASSEMBLY

Refer to parts list on page 6 for part numbers.

1. Place workbench top (#8) upside down on a smooth surface to prevent scratching the top of the workbench. (see figure 1)
2. Attach the legs (#6) to the workbench top (#8) with M8*65 bolts (#1), then secure with M8 nuts (#2). Finger tighten all nuts. Note the leg cross beams should be with the inset toward the center of the worktable. (see figure 2)

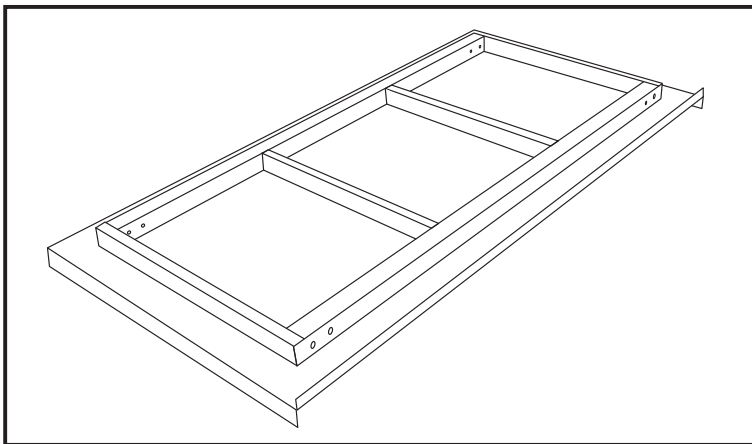

Figure 1

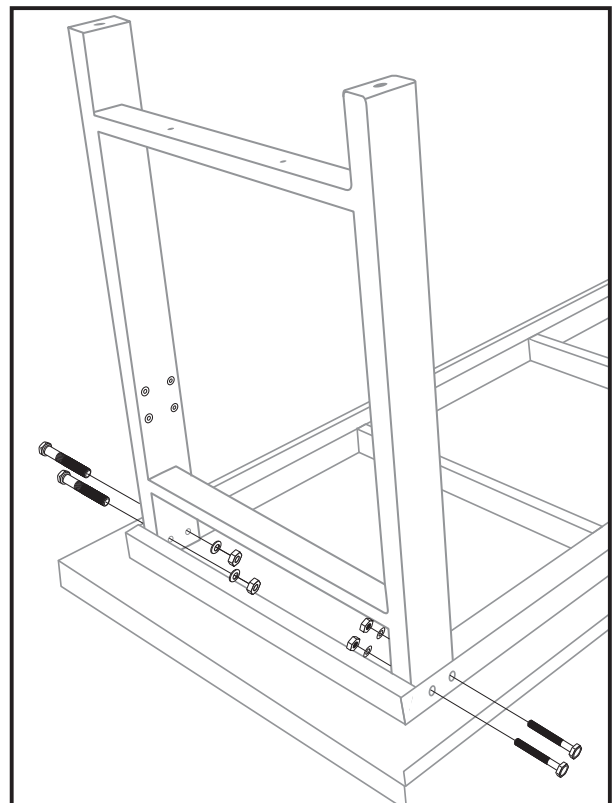

Figure 2

3. Slip an M6 washer (#3) onto each M6*20 bolt (#4) then attach the beam (#9) between the two sets of legs on the backside (side with the flange) of the workbench. Tighten them finger tight. (see figure 3)
4. Attach the feet (#5) to each of the four corners by screwing them into the threaded receiver at the bottom at each corner. (see figure 4)

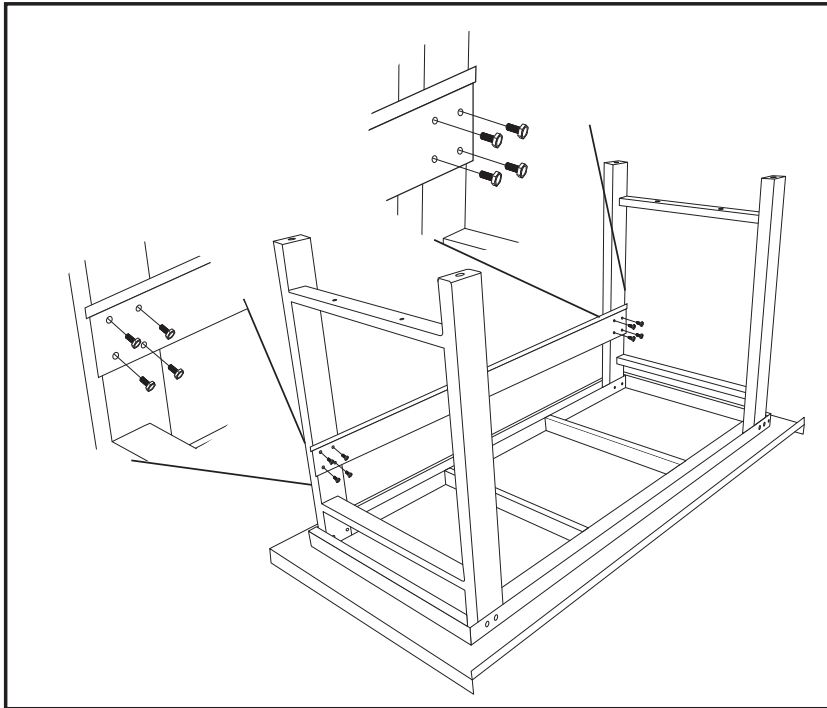

Figure 3

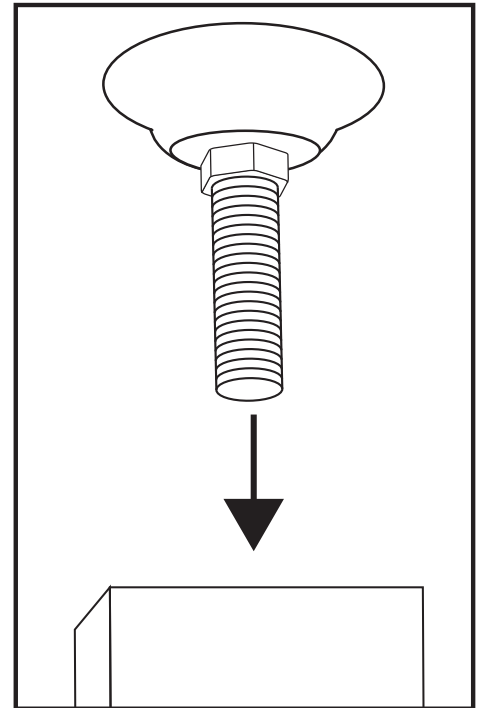

Figure 4

5. Square the entire unit and use a wrench or socket set to tighten all fasteners.
6. Place the workbench in its upright position and assemble the shelf (#7) to the workbench. Thread M6 washer (#3) onto M6*45 bolt (#10) and thread through shelf into the leg beams (#6) on each side. (see figure 5)
7. Tighten all hardware and adjust feet to ensure that the bench top is level.

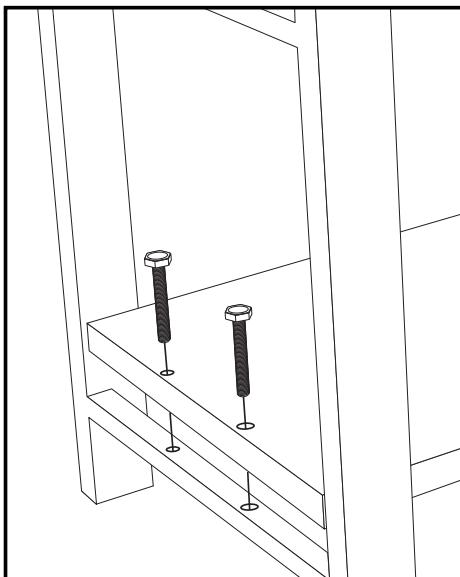

Figure 5

MAINTENANCE

Clean surfaces with a mild detergent and water, or non-flammable cleaning products like glass cleaners or non-abrasive household cleaners.

DO NOT USE FLAMMABLE LIQUIDS. Metal surfaces can be waxed with standard auto wax to protect the finish. Periodically check to ensure that all hardware is tight and that the work surface is level.

REPLACEMENT PARTS

Not all components of this workbench are replacement items, but are illustrated as a convenient reference for position in the assembly sequence. When ordering parts, give model number, part number and description. Call your distributor for current pricing.

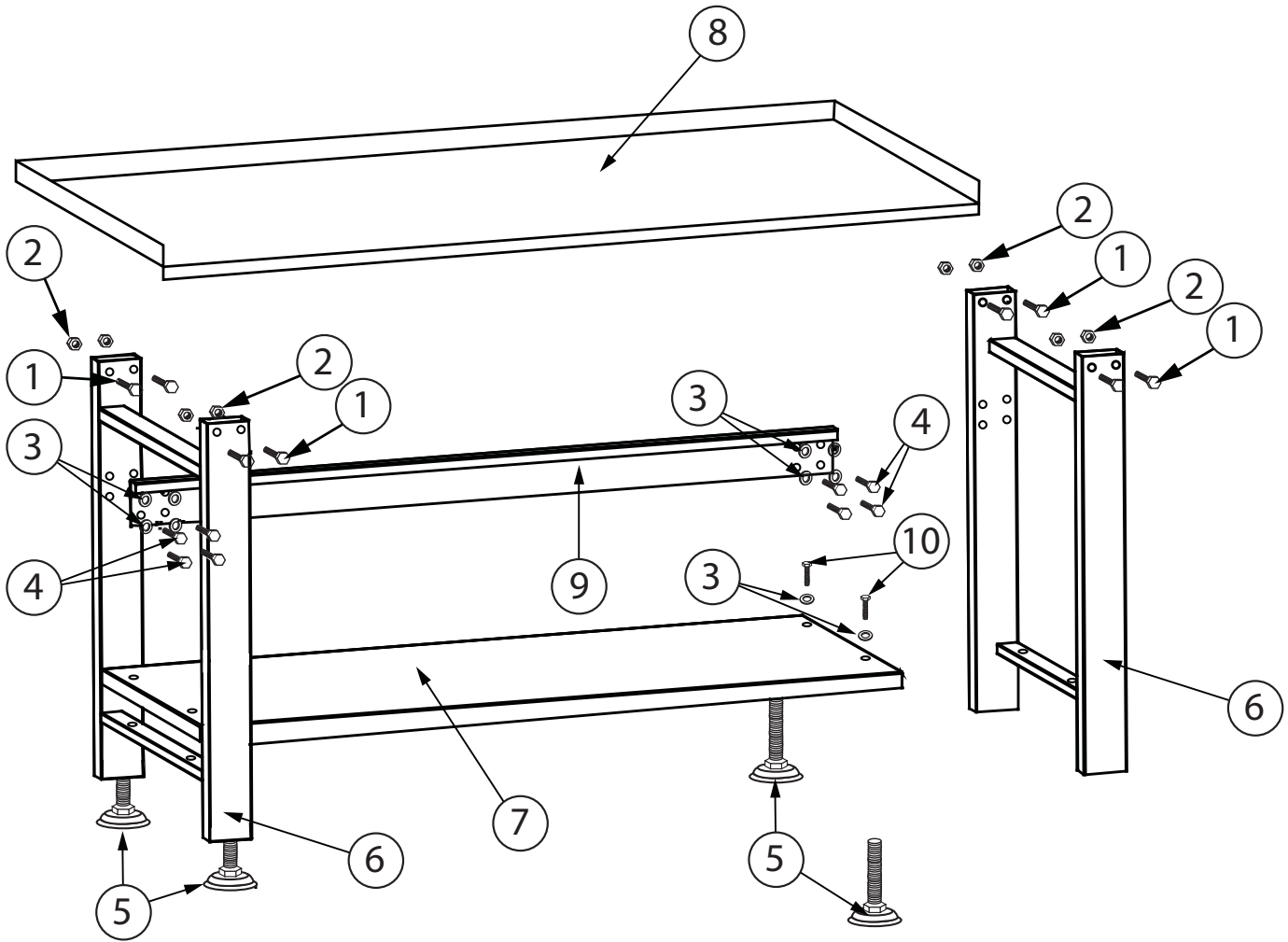

ITEM#	ORDERING PART#	PART DESCRIPTION	QTY
1	PRT70360-HK	M8 x 65 BOLT	8
2	PRT70360-HK	M8 NUT	8
3	PRT70360-HK	M6 WASHER	12
4	PRT70360-HK	M6 x 20 BOLT	8
5	PRT70360-05	ADJUSTABLE FEET	4
6	PRT70360-06	LEG	2
7	PRT70360-07	SHELF	1
8	PRT70360-08	WORKTOP	1
9	PRT70360-09	BEAM	1
10	PRT70360-HK	M6 x 45 BOLT	4



ATD[®]

WARRANTY

1 YEAR LIMITED WARRANTY

THIS WARRANTY AND CONFIRMED RECEIPT(S) SHOULD BE RETAINED BY THE CUSTOMER AT ALL TIMES

PURCHASED FROM: _____

DATE PURCHASED: _____

INVOICE/RECEIPT NUMBER: _____

Your ATD-70360 is warranted for a period of 12 months from the original purchase date.

For a period of one (1) year from your purchase date, ATD Tools, Inc. will repair or replace (at its option) without charge, your ATD product if it was purchased new and the product has failed due to a defect in material or workmanship which you experienced during normal use of the product. This limited warranty is your exclusive remedy.

To access the benefits of this warranty, contact your supplier, or point of sale directly. You may be advised to return the product under warranty, freight prepaid, to your supplier for warranty determination.

If this ATD product is altered, abused, misused, modified, or undergoes service by an unauthorized technician, your warranty will be void. We are not responsible for damage to ornamental designs you place on this ATD product and such ornamentation should not cover any warnings or instructions or they may void the warranty. This warranty does not cover scratches, superficial dents, and other abrasions to the paint finish that occur under normal use. It also does not cover normal wear items such as but not limited to brushes, batteries, drill bits, drill chucks, pads or blades.

Subject to the law in your state:

- (1) Your sole and exclusive remedy is repair or replacement of the defective product as described above.
- (2) ATD is not liable for any incidental damages, including but not limited to, lost profits and unforeseeable consequences.
- (3) The repair and replacement of this product under the express limited warranty described above is your exclusive remedy and is provided in lieu of all other warranties, express or implied. All other warranties, including implied warranties and warranties of merchantability or fitness for a particular purpose are disclaimed and, if disclaimer is prohibited, these warranties are limited to one year from your date of purchase of this product.

Some states' laws do not allow limited durations on certain implied warranties and some states' laws do not allow limitations on incidental or consequential damages. You should consult the law in your state to determine how your rights may vary.

[Affix receipt or invoice here for safe keeping]