



ATD-70320 Heavy-Duty 60" Workbench Owner's Manual



Features:

- Heavy-duty 14 gauge steel construction
- Durable powder coat finish
- Easy to assemble
- Adjustable foot pads for placement on slightly uneven surfaces

Specifications:

- 60" L x 30" D x 34" H
- Weight Capacity: 300 lbs.
- Shipping Weight: 265 lbs.

SAFETY INFORMATION

The following explanations are displayed in this manual, on the labeling, and on all other information provided with this product:

 **DANGER** indicates a hazardous situation which, if not avoided, will result in death or serious injury.

 **CAUTION** used with the safety alert symbol, indicates a hazardous situation which, if not avoided, could result in minor or moderate injury.

READ INSTRUCTIONS

- Thoroughly read and understand this manual before using.
- Save for future reference.

FALL HAZARD

- Awkward, out of balance body positions may be attempted while trying to reach specific areas of objects placed on the Heavy-Duty Workbench during use. Failure to ensure proper footing can quickly result in a fall which could inflict serious personal injury or property damage.
- This Heavy-Duty Workbench is designed for use in a shop environment only.
- **DO NOT** concentrate a heavy load to any corner or edge of the Heavy-Duty Workbench. This can cause the balance to shift suddenly, tipping the Heavy-Duty Workbench forward.
- **DO NOT** exceed the rated 300 lbs. [136 kg.] weight capacity.
- **DO NOT** use as a seat.
- **DO NOT** stand on the Heavy-Duty Workbench.
- **DO NOT** use the top of the Heavy-Duty Workbench as a storage surface.

PINCH HAZARD

- This Heavy-Duty Workbench has heavy components that can crush and pinch. Keep fingers and hands away from pinch points when assembling and during use.

ASSEMBLY

Step 1 - Begin by attaching two side plates (#9) and rear plate (#10) onto the table plate (#5) with five (5) M8x14 hex screws, as shown

Step 2 - Attach two rear legs (#11) and two front legs (#6) onto table plate (#8) using thirty-two (32) M8 x 14 hex screws and thirty-two (32) M8 flange nuts, as shown. Notice the difference between the rear legs and front legs.

Step 3 - Attach two side braces (313) and rear brace (#12) to the bench legs using twelve (12) M8x14 hex screws, as shown.

Step 4 - Fasten two (2) No. 8 flat washers, three (3) M8 hex nuts, and one (1) support washer plate onto each end of the bench legs using four (4) M12x70 bolts, as shown.

CAUTION:

Due to the size and considerable weight of the Heavy-Duty Workbench it is necessary to obtain the assistance of a capable helper during the following step:

Step 5 - With your helper lifting the opposite side, carefully raise and rotate the Heavy-Duty Workbench so that it may be set down on a level, hard surface. Your ATD-70320 Heavy-Duty Workbench is now ready for use.

MAINTENANCE

This Heavy-Duty Workbench is finished in rugged powder coating which will provide many years of service, however it is advisable to keep the finish clean and free from excessive dust and dirt.

- Keep the Heavy-Duty Workbench in a clean and dry environment. **DO NOT** store it in or expose it to a damp or wet environment.
- Occasionally inspect all components for potential damage and proper alignment. Check all hardware for tightness
- **DO NOT** use if damage is discovered.
- **DO NOT** place heavy components on one extreme corner or edge of the Heavy-Duty Workbench. This can cause the balance to shift suddenly, tipping the Heavy-Duty Workbench.
- Store the Heavy-Duty Workbench on a flat, level surface only to prevent possible unattended tipping and property damage.

1

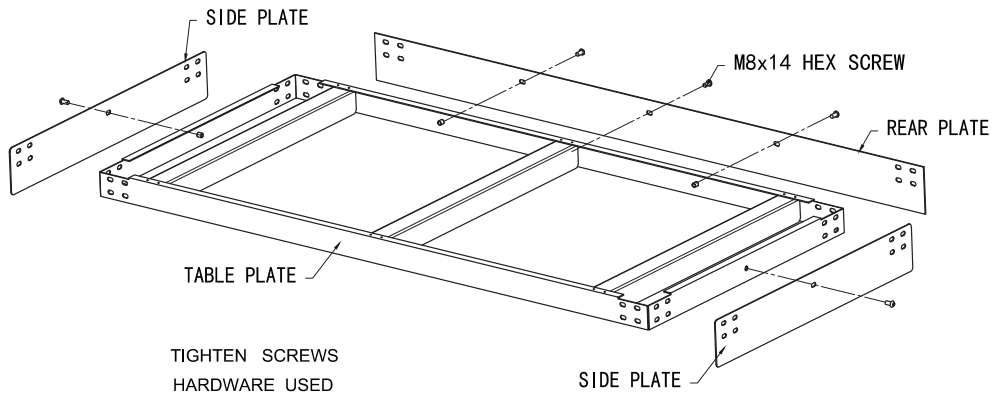

TIGHTEN SCREWS
HARDWARE USED

M8x14 HEX SCREW 5 

2

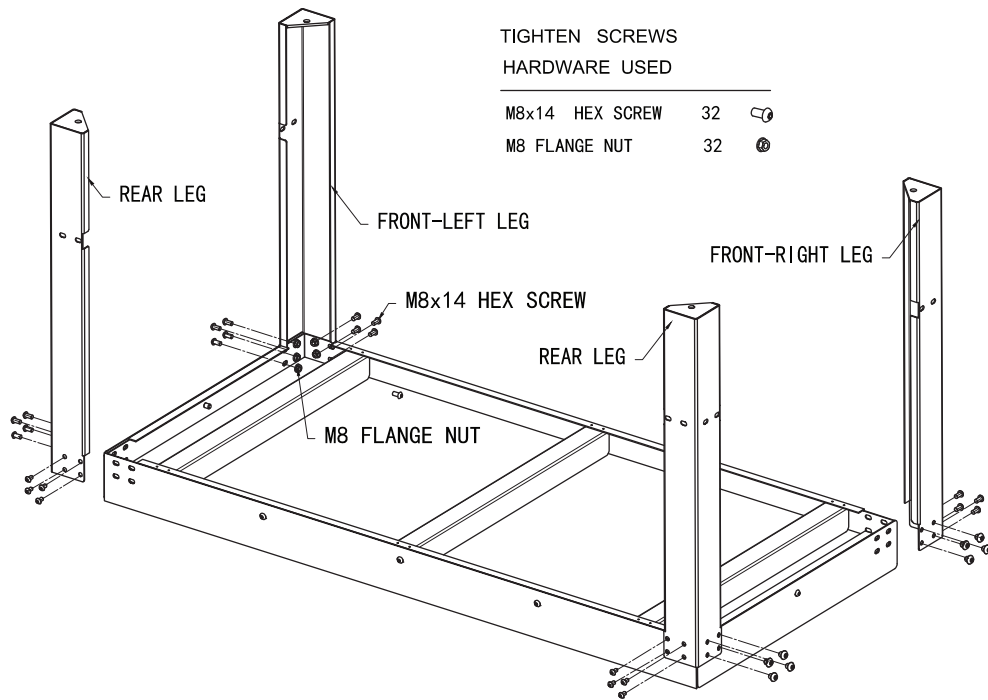

TIGHTEN SCREWS
HARDWARE USED

M8x14 HEX SCREW 32 

M8 FLANGE NUT 32 

3

TIGHTEN SCREWS
HARDWARE USED

M8x14	HEX SCREW	12	
-------	-----------	----	---

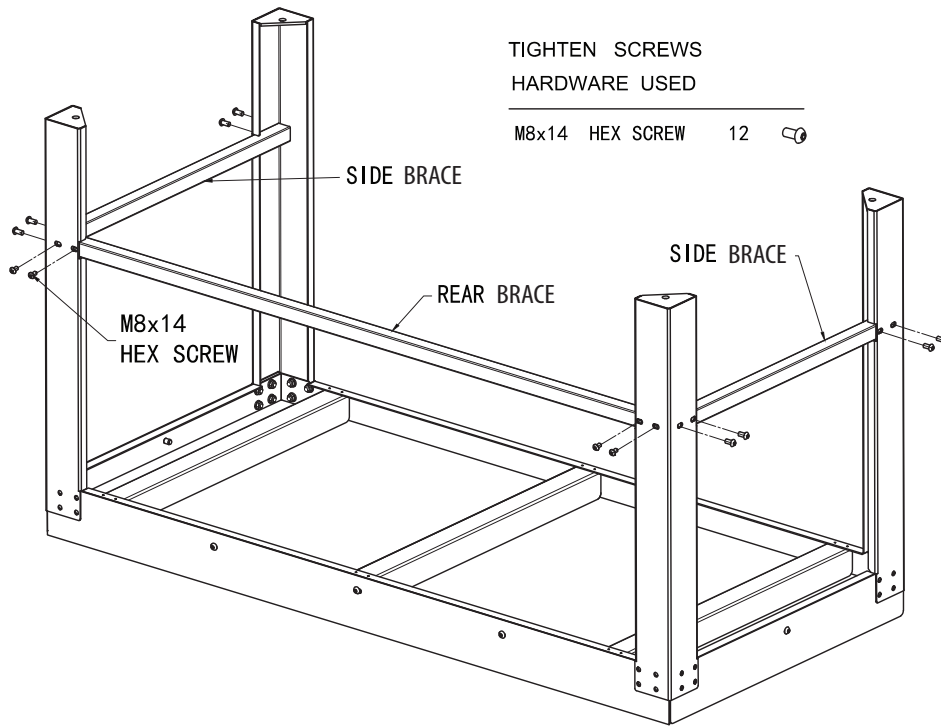

4

TIGHTEN SCREWS
HARDWARE USED

M12x70	BOLT	4
M8	HEX NUT	12
8	FLAT WASHER	8

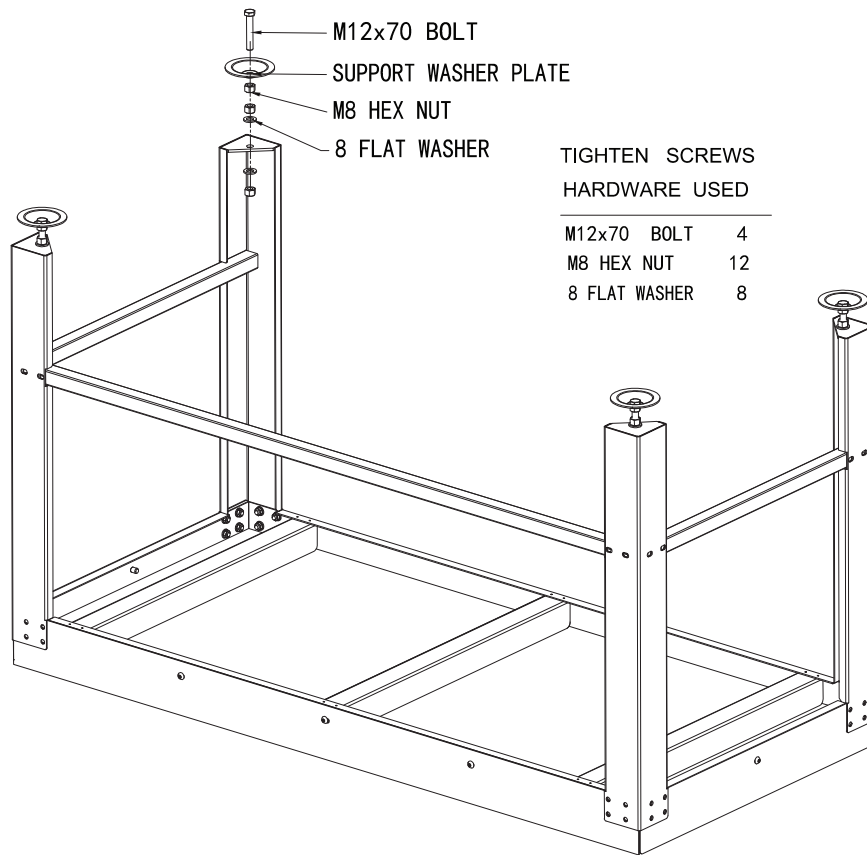



ATD-70320

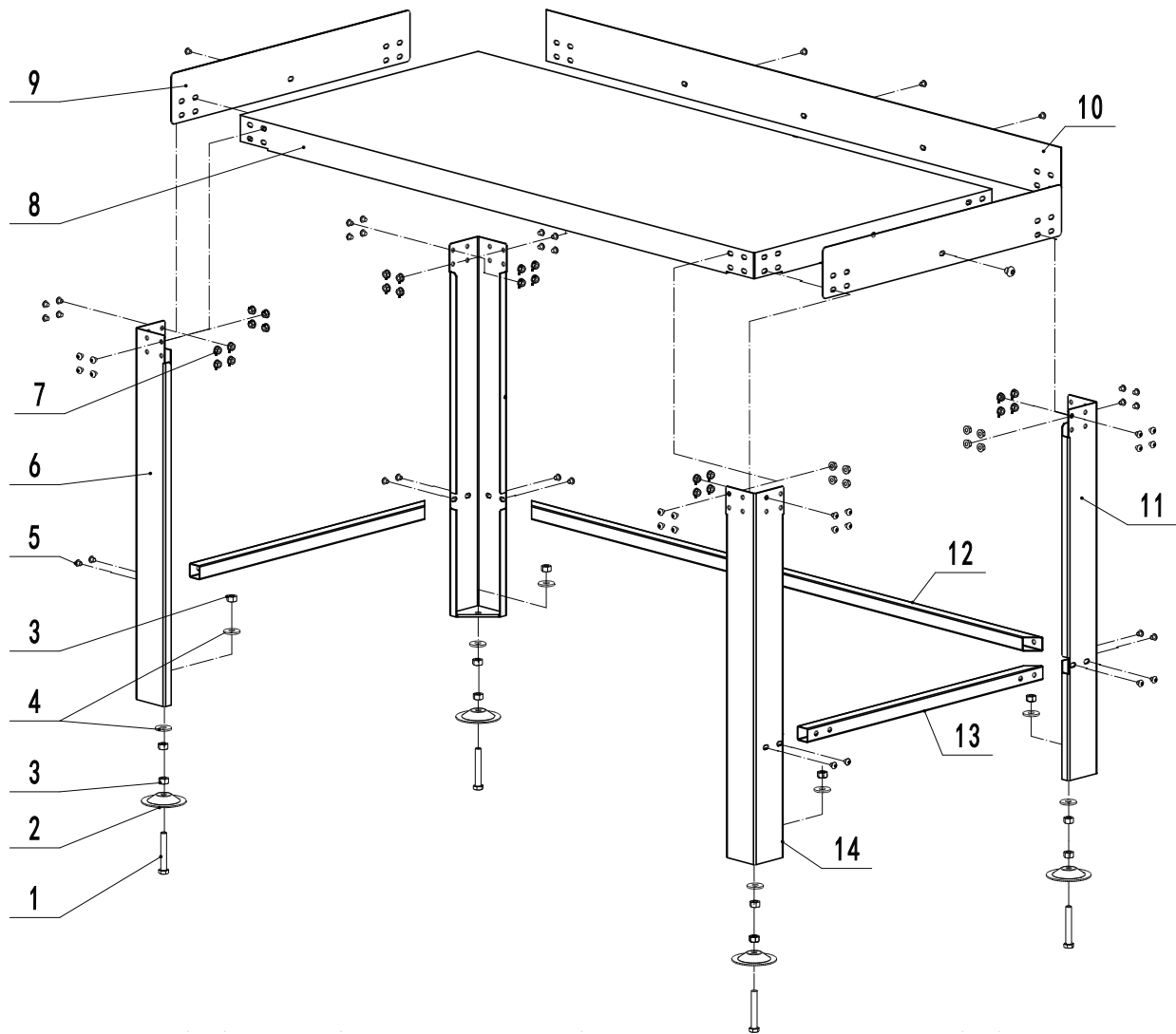

ITEM#	ORDERING PART#	PART DESCRIPTION
1	PRT70320-HK	BOLT
2	PRT70320-02	SUPPORT WASHER PLATE
3	PRT70320-HK	HEX NUT
4	PRT70320-HK	FLAT WASHER
5	PRT70320-HK	HEX SCREW
6	PRT70320-06	FRONT LEFT LEG
7	PRT70320-HK	FLANGE NUT
8	PRT70320-08	TABLE PLATE
9	PRT70320-09	SIDE PLATE
10	PRT70320-10	REAR PLATE
11	PRT70320-11	REAR LEG
12	PRT70320-12	REAR BRACE
13	PRT70320-13	SIDE BRACE
14	PRT70320-14	FRONT RIGHT LEG

Not all components are replacement items, but are illustrated as a convenient reference of parts location and for reference to the assembly instructions.
 Call your distributor for current pricing. When ordering parts, give part number and parts description.



WARRANTY

1 YEAR LIMITED WARRANTY

THIS WARRANTY AND CONFIRMED RECEIPT(S) SHOULD BE RETAINED BY THE CUSTOMER AT ALL TIMES

PURCHASED FROM: _____

DATE PURCHASED: _____

INVOICE/RECEIPT NUMBER: _____

Your ATD-70320 is warranted for a period of 12 months from the original purchase date.

For a period of one (1) year from your purchase date, ATD Tools Inc. will repair or replace (at its option) without charge, your ATD product if it was purchased new and the product has failed due to a defect in material or workmanship which you experienced during normal use of the product. This limited warranty is your exclusive remedy.

To access the benefits of this warranty, contact your supplier, or point of sale directly. You may be advised to return the product under warranty, freight prepaid, to your supplier for warranty determination.

If this ATD product is altered, abused, misused, modified, or undergoes service by an unauthorized technician, your warranty will be void. We are not responsible for damage to ornamental designs you place on this ATD product and such ornamentation should not cover any warnings or instructions or they may void the warranty. This warranty does not cover scratches, superficial dents, and other abrasions to the paint finish that occur under normal use. It also does not cover normal wear items such as but not limited to brushes, batteries, drill bits, drill chucks, pads or blades.

Subject to the law in your state:

- (1) Your sole and exclusive remedy is repair or replacement of the defective product as described above.
- (2) ATD is not liable for any incidental damages, including but not limited to, lost profits and unforeseeable consequences.
- (3) The repair and replacement of this product under the express limited warranty described above is your exclusive remedy and is provided in lieu of all other warranties, express or implied. All other warranties, including implied warranties and warranties of merchantability or fitness for a particular purpose are disclaimed and, if disclaimer is prohibited, these warranties are limited to one year from your date of purchase of this product.

Some states' laws do not allow limited durations on certain implied warranties and some states' laws do not allow limitations on incidental or consequential damages. You should consult the law in your state to determine how your rights may vary.

[Affix receipt or invoice here for safe keeping]