



ATD-6577 Painting Prep Cart Owner's Manual



Features:

- Saves space and reduces waste
- Durable wire shelves
- Powder coated steel construction
- (4) 4" polyurethane casters (2 swivel, 2 with brake)

Specifications:

- (3) Hooks
- (3) Small Bottle Mounts
- (3) Large Bottle Mounts
- Sanding Paper Roll Holder
- Masking Paper Dispenser
- Max. load capacity: 66 lbs per shelf

SAFETY INFORMATION

Assembly Precautions

1. Assemble only according to these instructions. Improper assembly can create hazards.
2. Wear ANSI-approved safety goggles and heavy-duty work gloves during assembly .
3. Keep assembly area clean and well lit.
4. Keep bystanders out of the area during assembly.
5. Do not assemble or use this device when tired or when under the influence of drugs or medication.
6. Weight capacity and other product capabilities apply to properly and completely assembled product only.

User Precautions

1. This Painting Prep Cart is not a toy. Do not allow children to play with or near this Painting Prep Cart .
2. Use as intended only.
3. Inspect before every use; do not use if parts are loose, damaged or missing.
4. Do not exceed listed weight capacity, evenly distributed. Be aware of dynamic loading. Sudden load movement may briefly create excess load causing product failure.
5. Use only on flat, level, hard surface able to properly support your painting tools and accessories.

ASSEMBLY INSTRUCTIONS

NOTE: Leave ALL nuts and bolts hand tight until everything is together, and aligned. Refer to pages 3-5 of this manual for more detail. Lettered Details A-H are shown on the parts breakdown page.

- 1) Attach the Cross Frame (#4) to the Side Frames (#3) using the Bolts M8 x 20 (#15) as shown in Figure 1 and 2, and Detail D.
- 2) Attach the Casters (#32 & #31) to the Side Frames as shown in Figures 3 and 4.
- 3) Attach Wire Shelf (#5) to the bottom of your frame assembly, using M8 x 40 Bolt (#16), two of M8 Washer (#21) and M8 Nut (#24) as shown in Figure 5 and Detail C.
- 4) Attach Paper Support Frame (#12) between the Side Frames (#3) in two places, as shown in Figures 7 & 8, and Detail G, and secure with M8 x 45 Bolt (#17).
- 5) Attach Paper Holders (#10 & #11) with M8 x 45 Bolt (#17) and secure with M8 Locking Nut (#24) to the Paper Support Frames as shown in Figures 9 and 10 and Detail H.
- 6) Slide Paper Stop Washers, Paper Stop Springs and Paper Stop Collars onto the vertical Paper Holder Bars (#11) as shown in Figure 11 and Detail F.
- 7) Assemble the 3 Tape Reels (#28) as shown in Figure 12 & 14 and Detail E.
- 8) Attach 16" Cutting Blade and Spring (#13) to the top horizontal bar of the Paper Cutter Holder (#10) with M6 x 30 Bolt and 2 of the 22" Cutting Blades and Springs to the middle and bottom horizontal bars of the vertical Paper Cutter Holder (#10) with M6 x 30 Bolt as shown in Figures 13 & 14.
- 9) Attach Wire Shelf (#5) to the top of your frame assembly, using M8 x 40 Bolt (#16), two of M8 Washer (#21) and M8 Nut (#24) as shown in Figure 5, and Detail C.
- 10) Secure the Upper Side Wire Frame (#2) to the Side Frames (#3) on each side with M8 x 45 Bolt (#17), M8 Washer (#21) and M8 Nut (#24) as shown in Figures 16, 17 and 18, and Detail B.
- 11) Secure the Upper Back Wire Frame (31) to the Upper Side Wire Frames (#2) with M6 x 50 Bolt (#20) and M6 Flange Nut (#22) as shown in figures 19 and 20 and in Detail A.
- 12) Attach the Sanding Paper Roll Holder (#9) to the side of the cart as shown in Figure 21, attach the Big Wire Baskets (38) and the Small Wire Baskets (#7) to the Wire Frames in whatever location you desire. Suggestions are shown in Figures 22 and 23.
- 13) Once satisfied with the alignment of your Paint Prep Cart, tighten all of the nuts and bolts. Your ATD-6577 Painting Prep Cart is now ready for use.

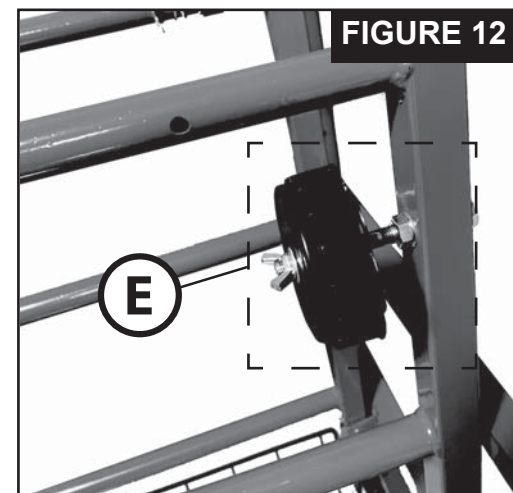
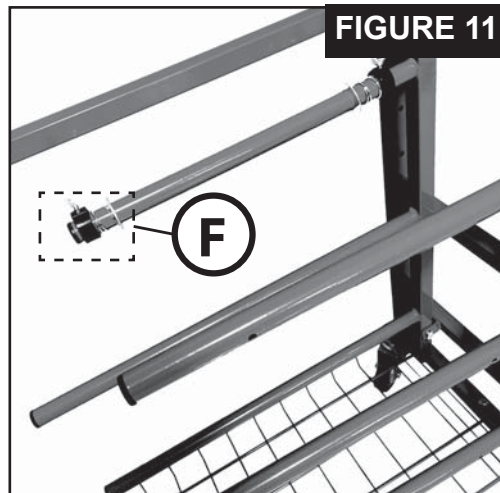
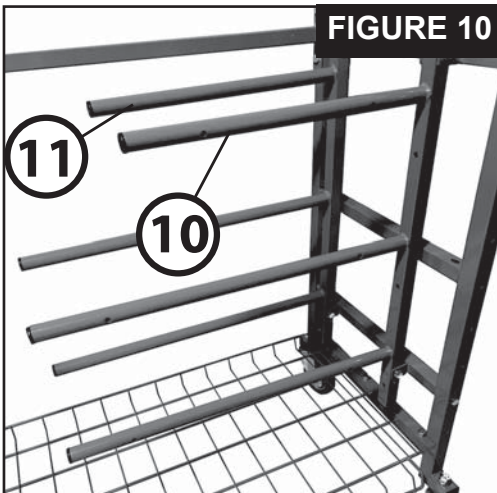
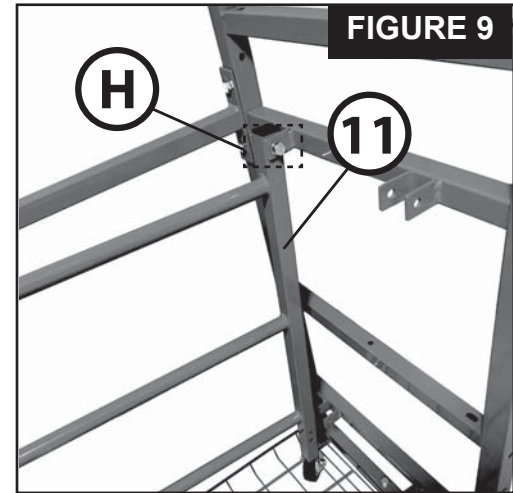
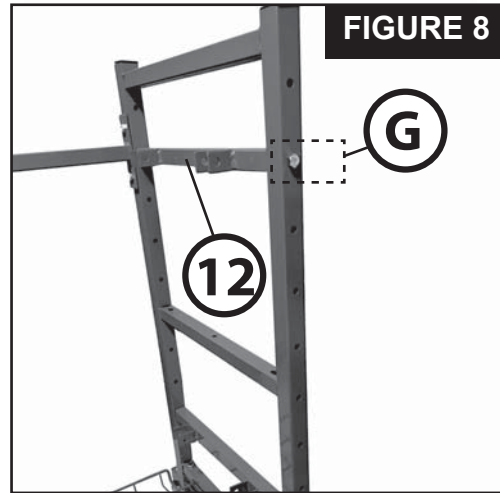
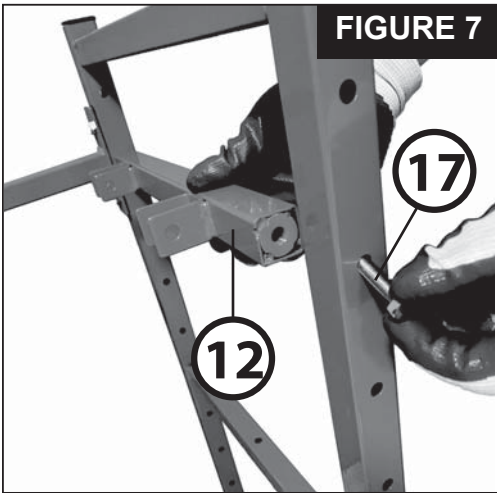
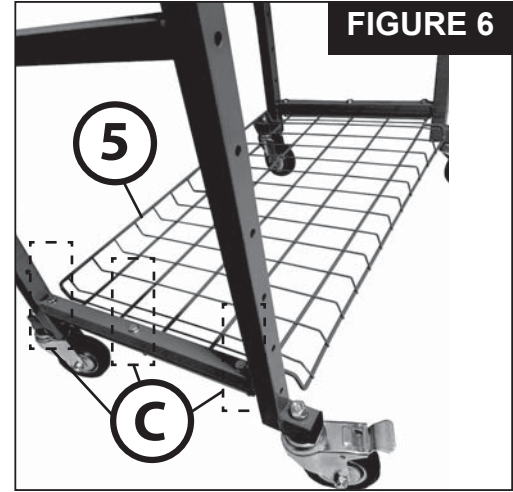
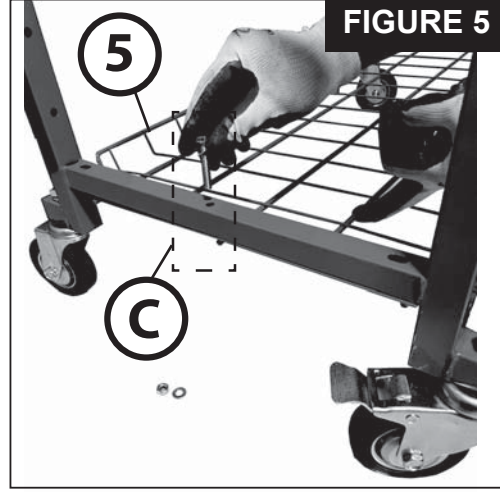
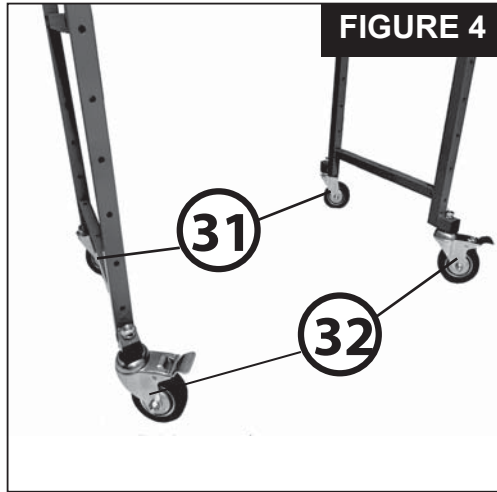
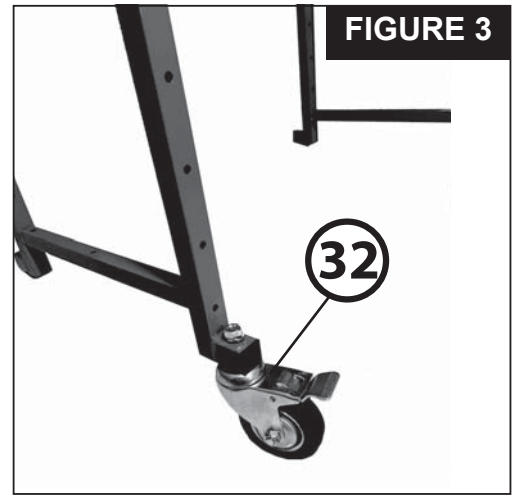
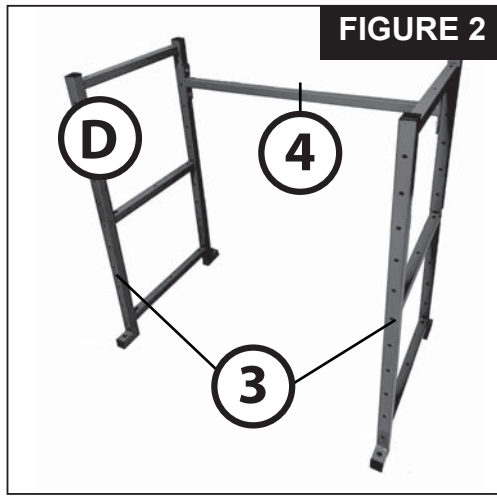
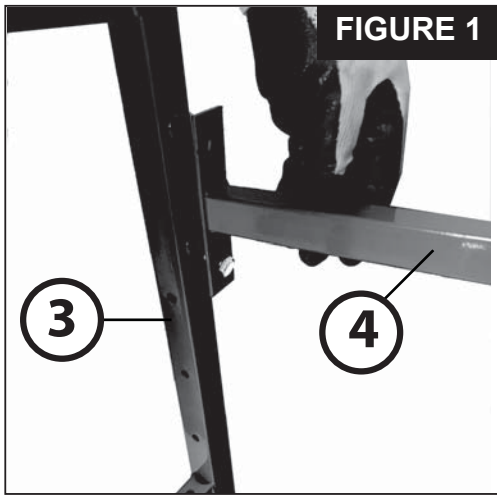

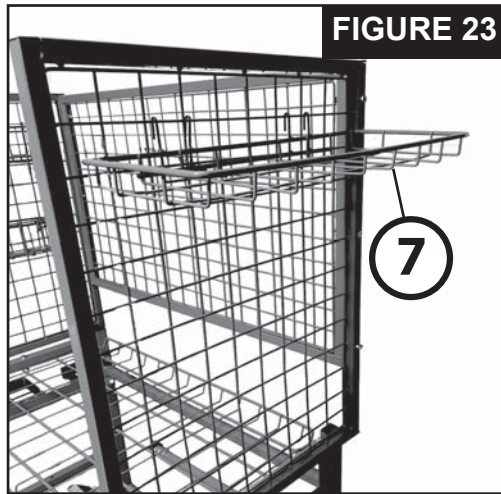
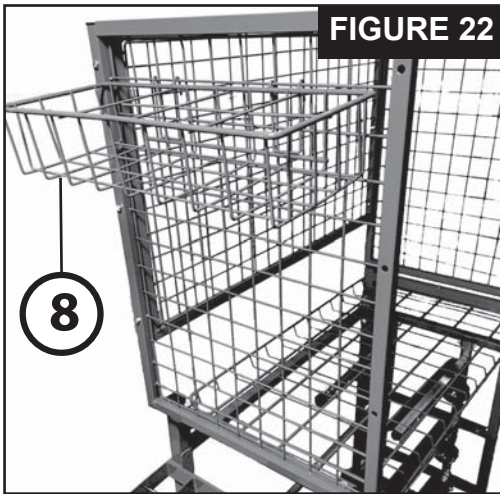
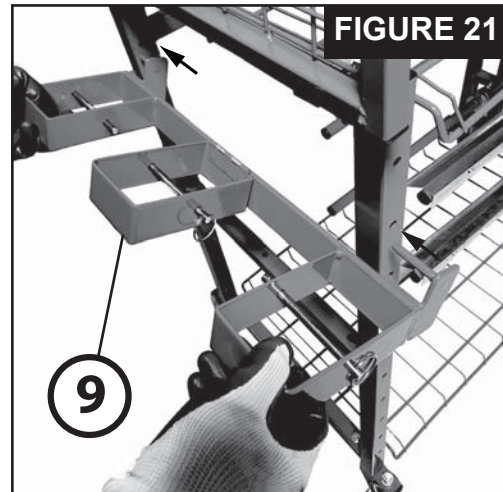
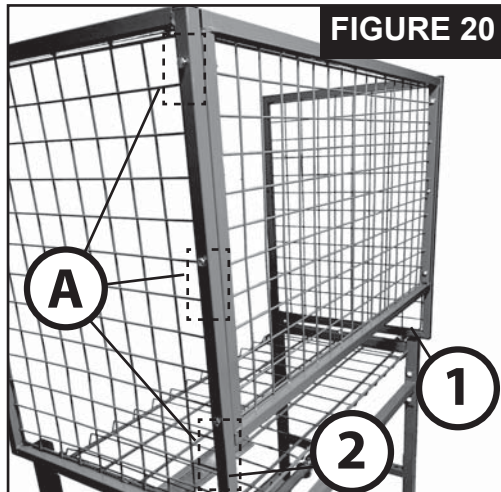
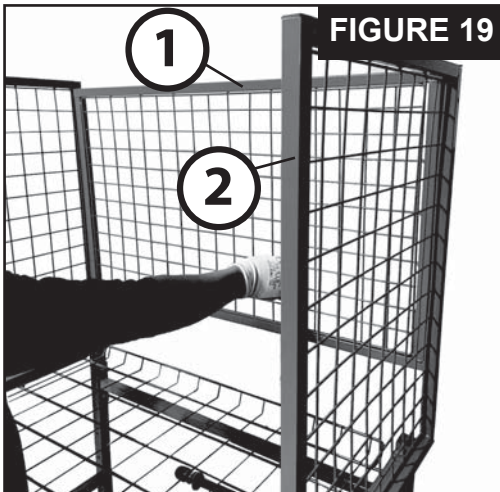
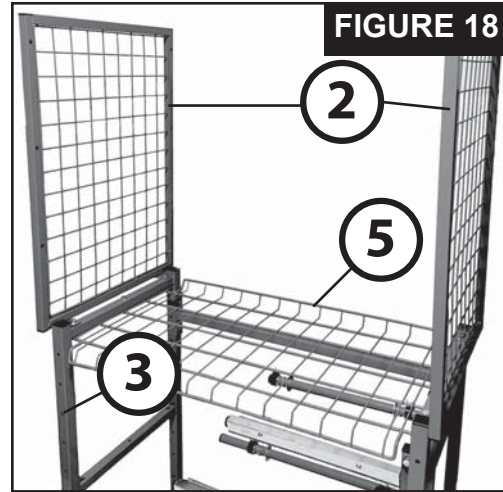
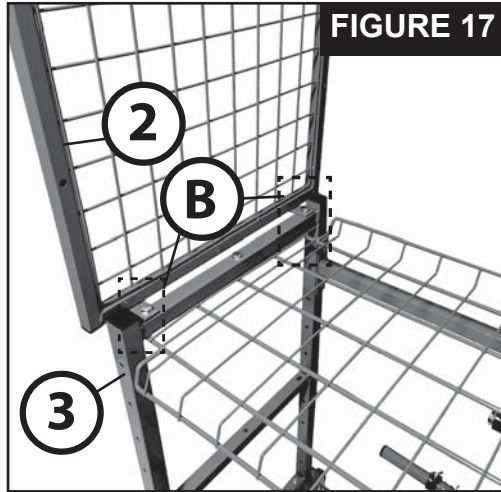
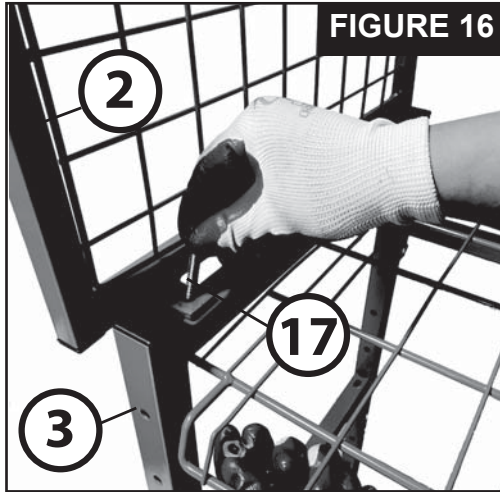
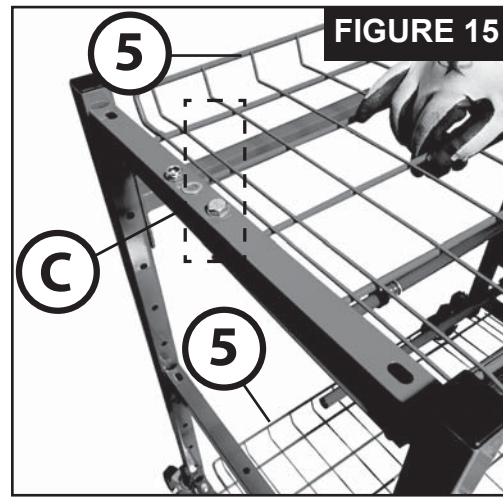
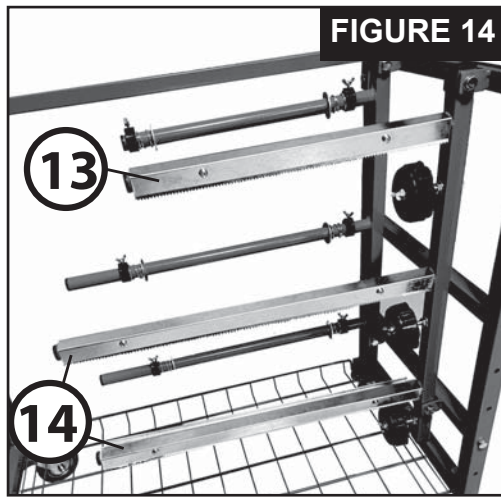
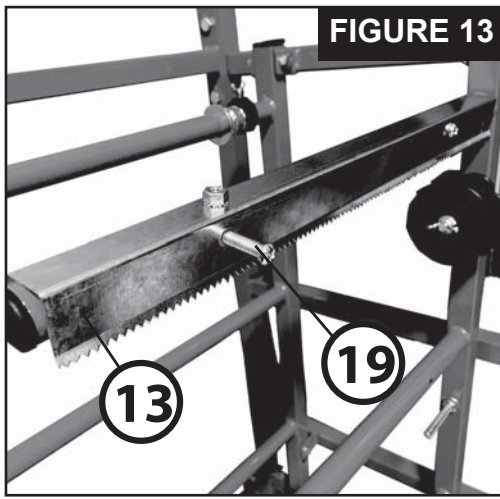

REPLACEMENT PARTS

Not all components of this product are replacement items, but are illustrated as a convenient reference for position in the assembly sequence. When ordering parts, give model number, part number and description. Call your distributor for current pricing:

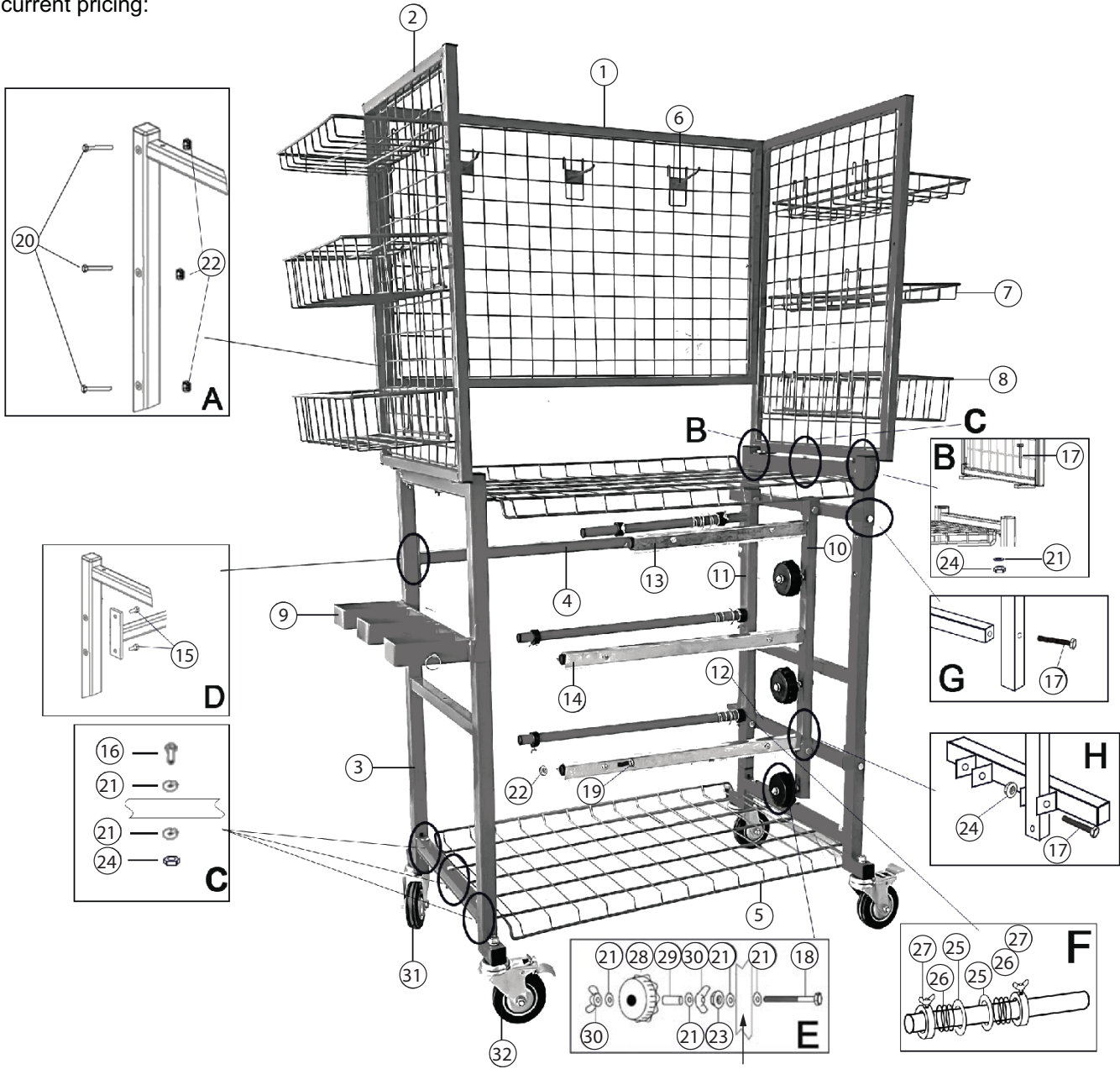

Paper Cutting Holder Tube (#10)

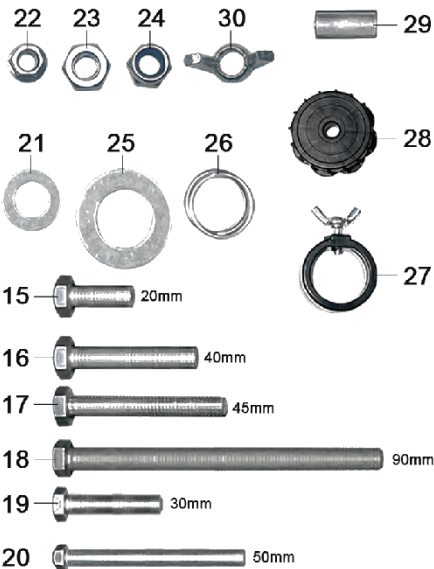

ITEM#	ORDERING PART#	PART DESCRIPTION	QTY
1	PRT6577-01	BACK WIRE FRAME	1
2	PRT6577-02	SIDE WIRE FRAME	2
3	PRT6577-03	SIDE FRAME	2
4	PRT6577-04	CROSS FRAME	1
5	PRT6577-05	WIRE SHELF	2
6	PRT6577-06	HOOK	3
7	PRT6577-07	SMALL WIRE BASKET	3
8	PRT6577-08	LARGE WIRE BASKET	3
9	PRT6577-09	SANDING PAPER ROLL HOLDER	1
10	PRT6577-10	PAPER CUTTER HOLDER	1
11	PRT6577-11	PAPER HOLDER	1
12	PRT6577-12	PAPER SUPPORT FRAME	2
13	PRT6577-13	16" CUTTING BLADE AND SPRING	1
14	PRT6577-14	22" CUTTING BLADE AND SPRING	2
15	PRT6577-HK	BOLT, M8 x 40	4
16	PRT6577-HK	BOLT, M8 x 40	12

ITEM#	ORDERING PART#	PART DESCRIPTION	QTY
17	PRT6577-HK	BOLT, M8 x 45	8
18	PRT6577-HK	BOLT, M8 x 90	3
19	PRT6577-HK	BOLT, M6 x 30	6
20	PRT6577-HK	BOLT, M6 x 50	6
21	PRT6577-HK	WASHER, M8	32
22	PRT6577-HK	FLANGE NUT, M6	12
23	PRT6577-HK	NUT, M8	3
24	PRT6577-HK	LOCK NUT, M8	16
25	PRT6577-HK	PAPER STOP WASHER	3
26	PRT6577-HK	PAPER STOP SPRING	3
27	PRT6577-HK	PAPER STOP COLLAR	3
28	PRT6577-HK	TAPE REEL	3
29	PRT6577-HK	TAPE REEL BUSHING	3
30	PRT6577-HK	WING NUT, M8	6
31	PRT6577-31	SWIVEL CASTER	2
32	PRT6577-32	SWIVEL CASTER W/BRAKE	2

PRT6577-HK - HARDWARE KIT INCLUDES 15, 16, 17, 18, 19, 20, 21, 22, 23, 24, 25, 26, 27, 28, 29 & 30



WARRANTY
1 YEAR LIMITED WARRANTY

THIS WARRANTY AND CONFIRMED RECEIPT(S) SHOULD BE RETAINED BY THE CUSTOMER AT ALL TIMES

PURCHASED FROM: _____

DATE PURCHASED: _____

INVOICE/RECEIPT NUMBER: _____

Your ATD-6577 is warranted for a period of 12 months from the original purchase date.

For a period of one (1) year from your purchase date, ATD Tools, Inc. will repair or replace (at its option) without charge, your ATD product if it was purchased new and the product has failed due to a defect in material or workmanship which you experienced during normal use of the product. This limited warranty is your exclusive remedy.

To access the benefits of this warranty, contact your supplier, or point of sale directly. You may be advised to return the product under warranty, freight prepaid, to your supplier for warranty determination.

If this ATD product is altered, abused, misused, modified, or undergoes service by an unauthorized technician, your warranty will be void. We are not responsible for damage to ornamental designs you place on this ATD product and such ornamentation should not cover any warnings or instructions or they may void the warranty. This warranty does not cover scratches, superficial dents, and other abrasions to the paint finish that occur under normal use. It also does not cover normal wear items such as but not limited to brushes, batteries, drill bits, drill chucks, pads or blades.

Subject to the law in your state:

- (1) Your sole and exclusive remedy is repair or replacement of the defective product as described above.
- (2) ATD is not liable for any incidental damages, including but not limited to, lost profits and unforeseeable consequences.
- (3) The repair and replacement of this product under the express limited warranty described above is your exclusive remedy and is provided in lieu of all other warranties, express or implied. All other warranties, including implied warranties and warranties of merchantability or fitness for a particular purpose are disclaimed and, if disclaimer is prohibited, these warranties are limited to one year from your date of purchase of this product.

Some states' laws do not allow limited durations on certain implied warranties and some states' laws do not allow limitations on incidental or consequential damages. You should consult the law in your state to determine how your rights may vary.

[Affix receipt or invoice here for safe keeping]