



## ATD-6576 Floor Bumper Storage Stand Owner's Manual



### Features:

- Double sided rack for storing painted or unpainted bumpers
- Heavy-duty powder coated steel construction for strength and durability

### Specifications:

- (4) 4" polyurethane casters (2 locking)
- Dimensions: 41"W x 37"D x 85"H
- (4) sets of 18" upper arms and (4) sets of 24" lower arms
- Capacity: 200 lbs.

# **SAFETY INFORMATION**

## **Assembly Precautions**

1. Assemble only according to these instructions. Improper assembly can create hazards.
2. Wear ANSI-approved safety goggles and heavy-duty work gloves during assembly .
3. Keep assembly area clean and well lit.
4. Keep bystanders out of the area during assembly.
5. Do not assemble or use this device when tired or when under the influence of drugs or medication.
6. Weight capacity and other product capabilities apply to properly and completely assembled product only.

## **User Precautions**

1. This Floor Bumper Storage Stand is not a toy. Do not allow children to play with or near this Floor Bumper Storage Stand .
2. Use as intended only.
3. Inspect before every use; do not use if parts are loose, damaged or missing.
4. Do not exceed listed weight capacity, evenly distributed. Be aware of dynamic loading. Sudden load movement may briefly create excess load causing product failure.
5. Use only on flat, level, hard surface able to properly support your painting tools and accessories.

# **ASSEMBLY INSTRUCTIONS**

**NOTE:** Leave ALL nuts and bolts hand tight until everything is together, and aligned. Refer to page 4 of this manual for hardware detail diagram.

- 1) Attach Lower Vertical Bar (6) to Base Bar (7) using bolts, washers and nuts (10, 11 & 12) as shown in Figure 1
- 2) Attach Lower Vertical Bar (5) to Base Bar (7) as in step 1, using bolts, washers and nuts (10, 11 & 12) as shown in Figure 1
- 3) Attach Bottom Connecting Bar (3) to the above assemblies as shown in Figures 1 & 2
- 4) Attach Casters (13) to each corner of Lower Frame Assembly as shown in Figures 3 & 4 with the Locking Washer and Nut shown in the hardware detail diagram. It is recommended to place one the locking casters on the same side, and the side that will be easiest to access when the Bumper Rack is in use.
- 5) Using bolts, washers and nuts (10, 11 & 12), attach Middle Connecting Bar (2) to the tops of Lower Vertical Bars (5) and (6) from the Lower Frame Assembly above, as shown in Figure 5
- 6) Attach Upper Vertical Bar (4) to the top of above assembly using bolts, washers and nuts (10, 11 & 12), as shown in Figure 5
- 7) Using bolts, washers and nuts (10, 11 & 12), attach Top Connecting Bar (1) to the above assembly, as shown in Figure 6
- 8) Slide the pins for the Long Support Bars (8) and for the Short Support Bars (9) into the frame of your Bumper Stand to suit your needs, as shown in Figures 6 & 7. Be mindful of the weight that will be on these Support Bars and be careful not to overload them. Damage to the bumpers and to the user could occur. These supports can be easily moved and reconfigured at any time.
- 9) Your ATD-6576 is ready to use.

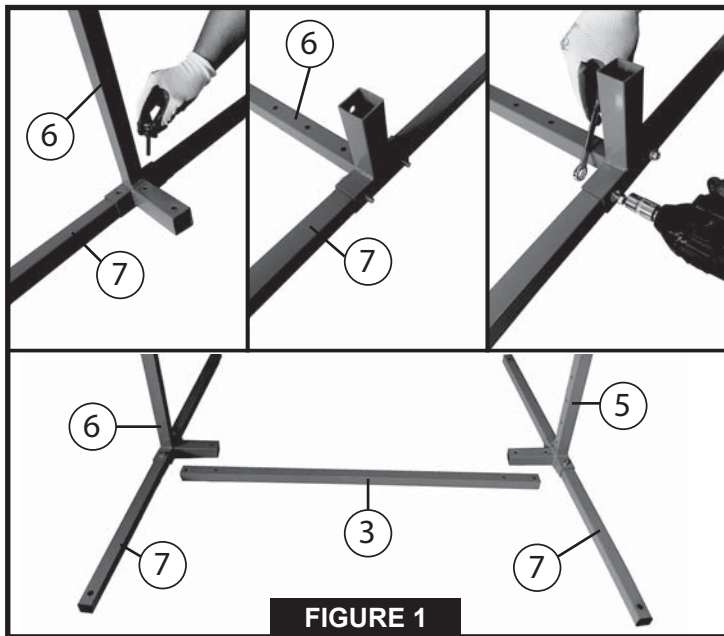

**FIGURE 1**

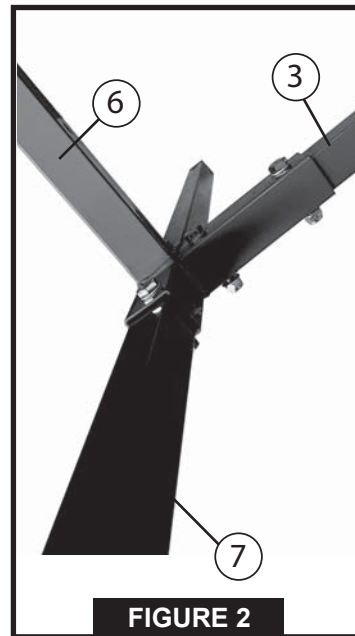

**FIGURE 2**

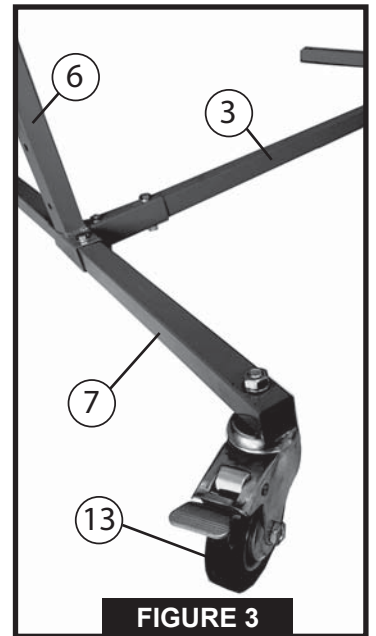

**FIGURE 3**

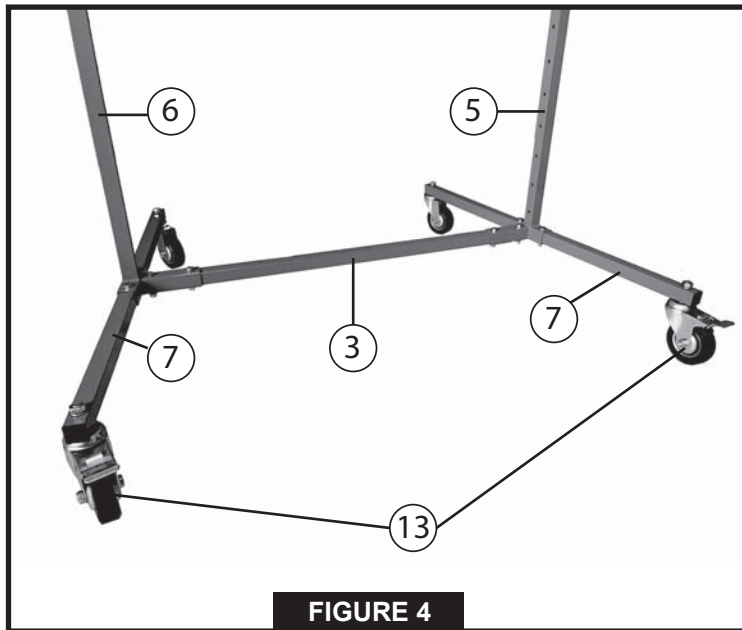

**FIGURE 4**

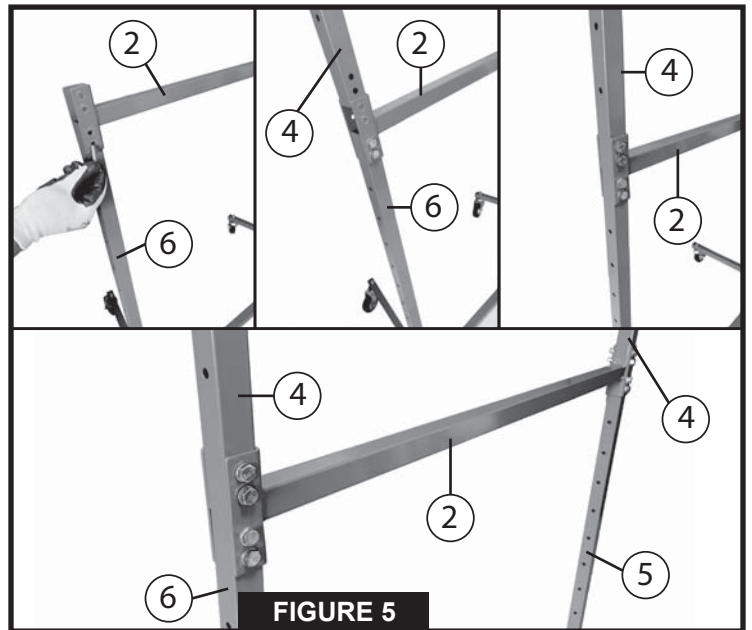

**FIGURE 5**

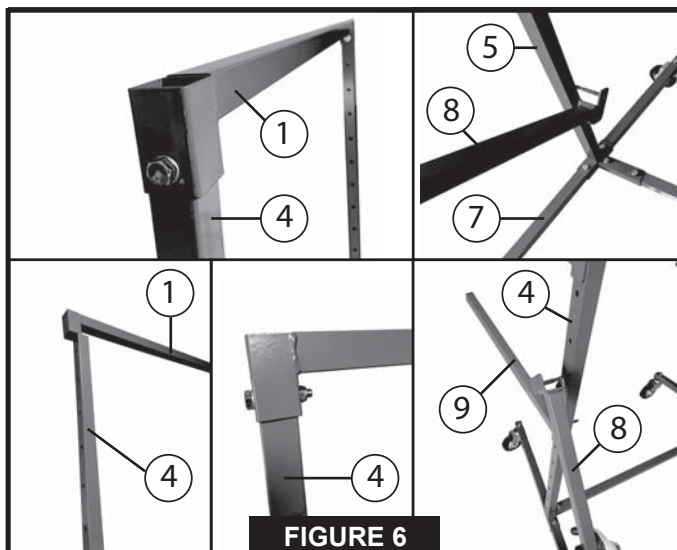

**FIGURE 6**

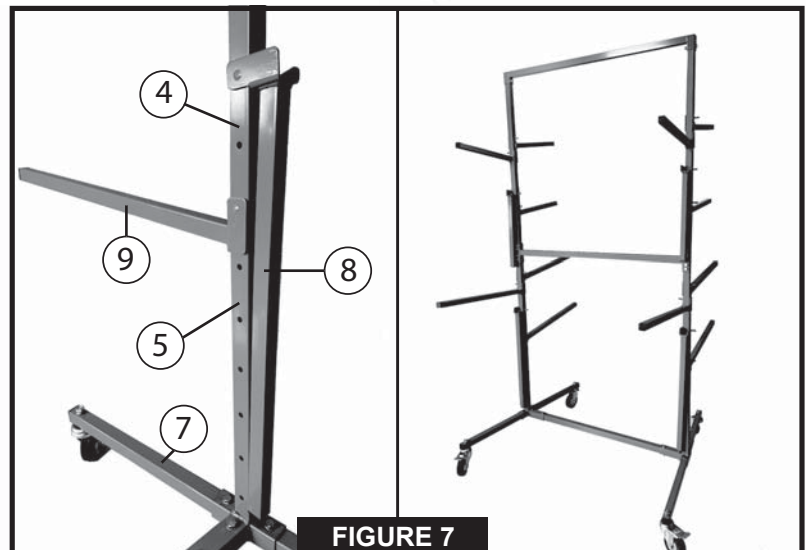
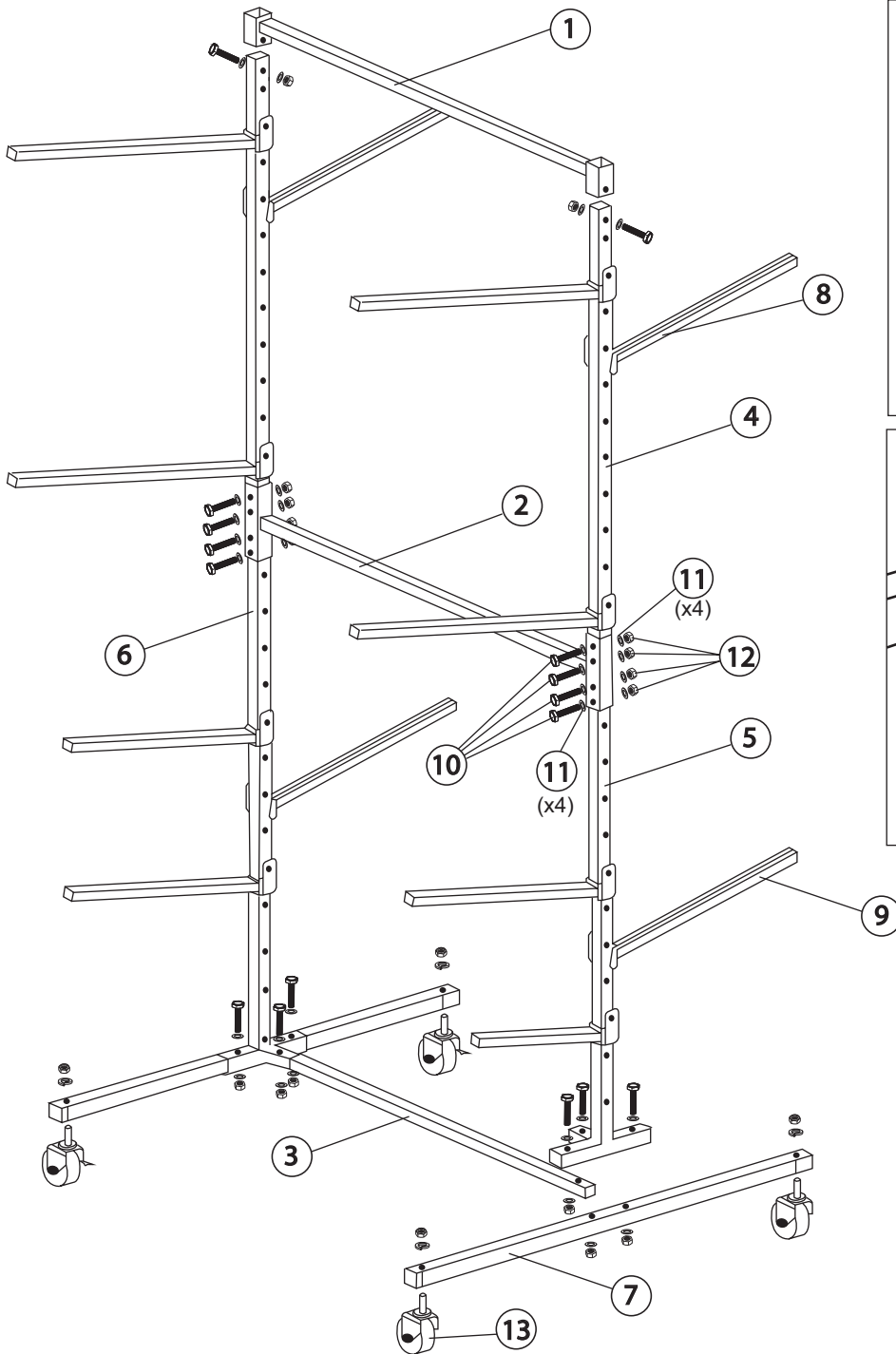
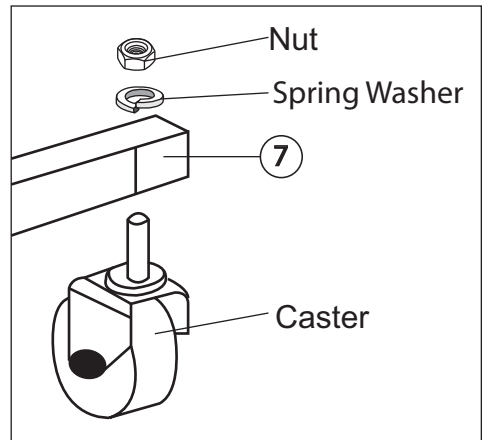
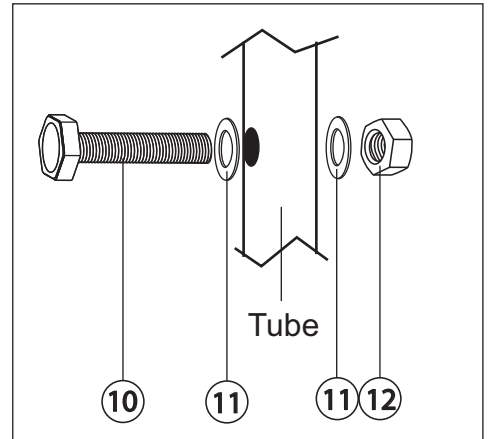

**FIGURE 7**

# REPLACEMENT PARTS

Not all components of this product are replacement items, but are illustrated as a convenient reference for position in the assembly sequence. When ordering parts, give model number, part number and description. Call your distributor for current pricing:

## HARDWARE FITMENT DIAGRAMS



ITEM#	ORDERING PART#	PART DESCRIPTION	QTY
1	PRT6576-01	TOP CONNECTING BAR	1
2	PRT6576-02	MIDDLE CONNECTING BAR	1
3	PRT6576-03	BOTTOM CONNECTING BAR	1
4	PRT6576-04	UPPER VERTICAL BAR	2
5	PRT6576-05	LOWER VERTICAL BAR (R)	1
6	PRT6576-06	LOWER VERTICAL BAR (L)	1
7	PRT6576-07	BASE BAR	2

ITEM#	ORDERING PART#	PART DESCRIPTION	QTY
8	PRT6576-08	LONG SUPPORT BAR	8
9	PRT6576-09	SHORT SUPPORT BAR	8
10	PRT6576-HK	BOLT, M8x50	18
11	PRT6576-HK	WASHER, M8	36
12	PRT6576-HK	NUT, M8	18
13	PRT6576-13	CASTERS (SET OF 4)	4

PRT6576-HK - HARDWARE KIT INCLUDES 10, 11 & 12



**THIS WARRANTY AND CONFIRMED RECEIPT(S) SHOULD BE RETAINED BY THE CUSTOMER AT ALL TIMES**

PURCHASED FROM: \_\_\_\_\_

DATE PURCHASED: \_\_\_\_\_

INVOICE/RECEIPT NUMBER: \_\_\_\_\_

Your ATD-6576 is warranted for a period of 12 months from the original purchase date.

For a period of one (1) year from your purchase date, ATD Tools, Inc. will repair or replace (at its option) without charge, your ATD product if it was purchased new and the product has failed due to a defect in material or workmanship which you experienced during normal use of the product. This limited warranty is your exclusive remedy.

To access the benefits of this warranty, contact your supplier, or point of sale directly. You may be advised to return the product under warranty, freight prepaid, to your supplier for warranty determination.

If this ATD product is altered, abused, misused, modified, or undergoes service by an unauthorized technician, your warranty will be void. We are not responsible for damage to ornamental designs you place on this ATD product and such ornamentation should not cover any warnings or instructions or they may void the warranty. This warranty does not cover scratches, superficial dents, and other abrasions to the paint finish that occur under normal use. It also does not cover normal wear items such as but not limited to brushes, batteries, drill bits, drill chucks, pads or blades.

Subject to the law in your state:

- (1) Your sole and exclusive remedy is repair or replacement of the defective product as described above.
- (2) ATD is not liable for any incidental damages, including but not limited to, lost profits and unforeseeable consequences.
- (3) The repair and replacement of this product under the express limited warranty described above is your exclusive remedy and is provided in lieu of all other warranties, express or implied. All other warranties, including implied warranties and warranties of merchantability or fitness for a particular purpose are disclaimed and, if disclaimer is prohibited, these warranties are limited to one year from your date of purchase of this product.

Some states' laws do not allow limited durations on certain implied warranties and some states' laws do not allow limitations on incidental or consequential damages. You should consult the law in your state to determine how your rights may vary.

[Affix receipt or invoice here for safe keeping]