



Hydraulic Air Pump

Operating Instructions & Parts Manual

Model Number
ATD-5812

Capacity
10,000 psi

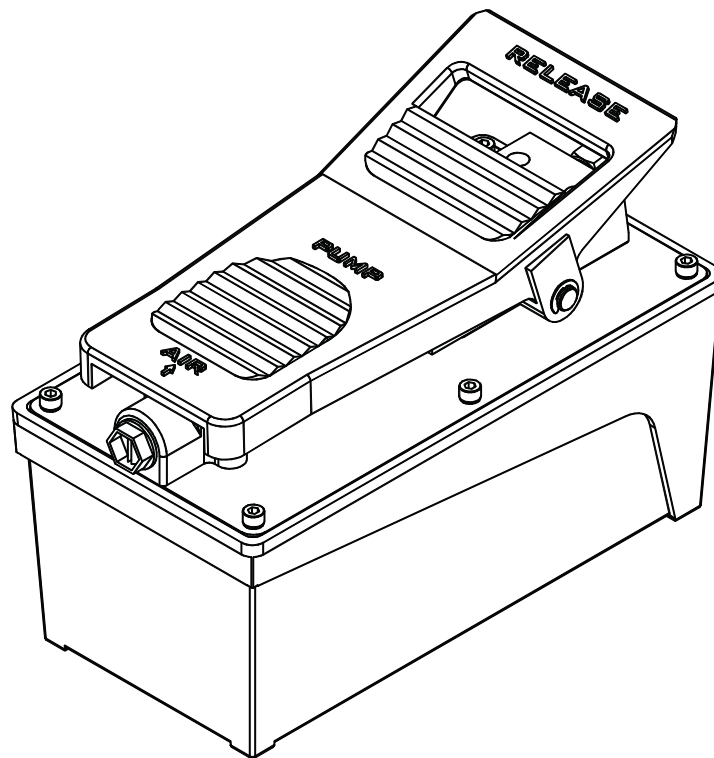

⚠ WARNING ⚠

WARNING: This product may contain chemicals, including lead, known to the State of California to cause cancer, birth defects or other reproductive harm. *Wash hands after handling.*

Made in Taiwan to ATD Tools, Inc. Specifications
Visit us at www.atdtools.com

Printed in Taiwan
ATD5812_rev_0417

Save these instructions. For your safety, read and understand the information contained within. The owner and operator shall have an understanding of this product and safe operating procedures before attempting to use this product. Instructions and Safety information shall be conveyed in the operators native language before use of this product is authorized. Make certain that the operator thoroughly understands the inherent dangers associated with the use and misuse of the product. If any doubt exists as to the safe and proper use of this product as outlined in this factory authorized manual, remove from service until which time it is clear. **Inspect before each use.** Do not use if broken, bent, cracked or otherwise damaged parts are noted. If the product has been or suspected to have been subjected to a shock load, discontinue use until checked out by an authorized factory service center. Owners and operators of this equipment shall be aware that the use and subsequent repair of this equipment may require special training and knowledge. It is recommended that an annual inspection be done by qualified personnel and that any missing or damaged parts, decals, warning / safety labels or signs be replaced with factory authorized replacement parts only. Any product that appears to be damaged in any way, is worn or operated abnormally should be removed from service immediately until such time as repairs can be made.

PRODUCT DESCRIPTION

ATD Tools 10,000 psi Heavy-Duty Hydraulic Air Pump is designed to operate on as little as 7.8 CFM @ 90 psi. This category of ATD Tools allows quick displacement of hydraulic fluid, up to 10,000 psi, to comparable rams, presses, spreaders, compactors and crimping machines, anywhere that 10,000 psi of fluid pressure is needed. Foot actuated treadle design delivers a metered, controllable flow to and from the intended application.

Note: Always check connections before using!

SPECIFICATIONS

Model Number	Usable Oil Capacity (in ³)	Rated Pressure (psi)	Output Flow Rate (in ³ /min)		Input Air Pressure (psi)	Oil Output Port Threads	Air Input Port Threads	Weight (lbs. w/fluid)
			No Load	Load				
ATD-5812	91.5 cu. in.	10,000 psi	61.02	19.53	110-175 psi	3/8"-18NPTF	1/4"-18NPTF	18.5 lbs.

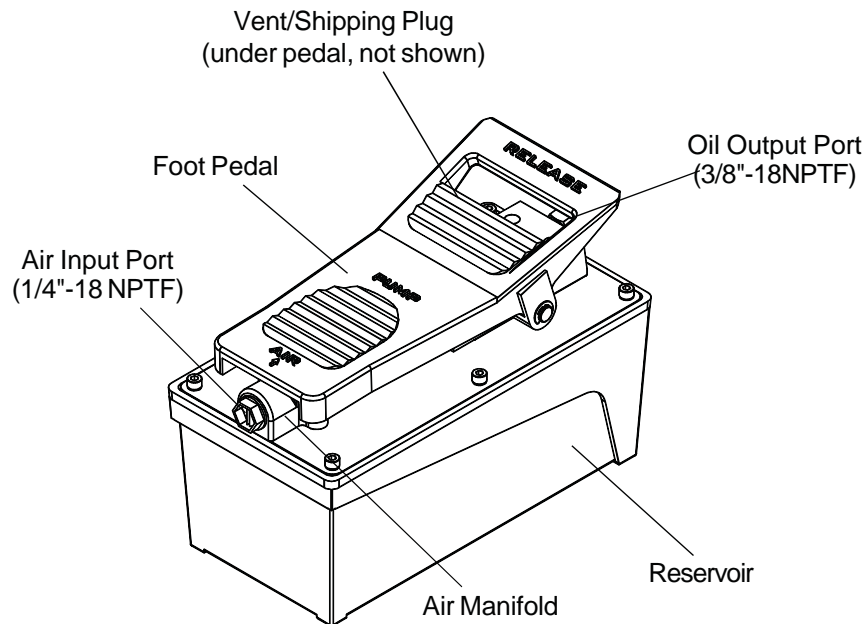

Figure 1- Model ATD-5812 nomenclature

WARNING

- Read and understand all warnings and instructional material provided on and with this product before use.
- Do not exceed rated capacity.
- Burst hazard exists if hose or connection pressure exceeds rated pressure.
- Never operate pump when it is disconnected from application. This will pressurize the hose and connections and increase the burst hazard.
- Use gauge or other load measuring instrument to verify load.
- Always inspect hoses and connections for damage prior to use.
- Always wear protective clothing and eye protection when operating this equipment.
- Always ensure that the chosen application is stable to work on and around.
- Do not work under a lifted load without adequately rated support devices such as jack stands.
- Do not subject the pump and its components to shock loads.
- Do not connect to application which can return more oil to the reservoir than the pump reservoir can hold.
- Failure to heed this warning may result in personal injury as well as property damage.

BEFORE USE

1. Verify that the product and the application are compatible, if in doubt call for Technical Assistance (888) 332-6419.
2. Before using this product, read the owner's manual completely and familiarize yourself thoroughly with the product, its components and recognize the hazards associated with its use.
3. Replace shipping plug (red color) with air vent plug (black color). This will help release any pressurized air which may be trapped within the reservoir. Ensure the oil level is just below the shipping plug hole.
4. Always check connections before using. Alteration of this product is strictly prohibited. Use only those adapters and attachments provided and approved by the manufacturer.

Note: Secure threaded port connections with non-hardening pipe thread compound. Tighten securely to prevent accidental removal of components while in use. Take care not to introduce compound into port orifices.

OPERATION

1. Connect to suitable application, then to air source of at least 7.8 CFM @ 90 psi.
2. To operate, press on the foot pedal until desired position is reached. Stop further application movement by releasing pressure on treadle.
3. To retract application, press the release valve by stepping on the raised, stirrup shaped portion of the foot pedal).

MAINTENANCE

1. Inspect hoses and connections daily. Replace damaged components immediately with factory authorized replacement parts only.
2. Tighten connections as needed. Use non-hardening pipe thread compound when servicing connections.
3. Use only good quality hydraulic fluid. We recommend Mobil DTE 13M or equivalent.

When not in use or during storage

- a. Depressurize and disconnect hydraulic hoses from application.
- b. Wipe clean, thoroughly.
- c. Store in clean, dry environment. Avoid extreme temperatures.
- d. For transportation or long storage, replace air vent plug (black color) with shipping plug (red color).
- e. Shield pump with a protective cover.

Adding Hydraulic Fluid

1. Depressurize and disconnect hydraulic hose from application.
2. With pump in its upright, horizontal position, remove the air vent plug located on the top plate of the reservoir.
3. Use a small funnel to fill reservoir to within 3/4" (19mm) of the opening.

Note: Use only a good quality hydraulic oil. **Never** use brake fluid, transmission fluid, turbine oil, motor oil, alcohol, glycerin etc. Use of other than good quality hydraulic oil will void warranty and damage the pump, hose, and application.

4. Wipe up any spilled fluid and reinstall the air vent plug.

Changing Hydraulic Fluid

For best performance and longest life, replace the complete fluid supply at least once per year.

1. Depressurize and disconnect hydraulic hose from application.
2. With pump in its upright, horizontal position, remove the air vent plug located on the top plate of the reservoir.
3. Use a small funnel to fill reservoir to within 3/4" (19mm) of the opening.
4. Pour used fluid into a sealable container.
5. Dispose of fluid in accordance with local regulations.
6. Fill with a good quality hydraulic oil as recommended above. Reinstall air vent plug.

Lubrication

Use a light machine oil to lubricate pivot points, hinges etc.

TROUBLESHOOTING

Symptom	Possible Causes	Corrective Action
Application will not extend, move or respond to pressurized fluid	<ul style="list-style-type: none"> • Overload condition 	<ul style="list-style-type: none"> • Remedy overload condition
Application responds to pressurized fluid, but system does not maintain pressure	<ul style="list-style-type: none"> • Overload condition • Hydraulic unit malfunction 	<ul style="list-style-type: none"> • Remedy overload condition • Contact Service Center
Application will not return fluid to pump (i.e. cylinder will not retract)	<ul style="list-style-type: none"> • Malfunctioning coupler, damaged application • Reservoir overfilled 	<ul style="list-style-type: none"> • Secure load by other means. Depressurize pump and hose, remove coupler and/or application, then renew or replace • Secure load by other means. Depressurize pump and hose, remove application, then drain fluid to proper level
Application will not fully extend (cylinder or spreader)	<ul style="list-style-type: none"> • Fluid level low 	<ul style="list-style-type: none"> • Secure load by other means. Depressurize pump and hose, remove application, then ensure proper fluid level
Poor performance	<ul style="list-style-type: none"> • Fluid level low 	<ul style="list-style-type: none"> • Ensure proper fluid level

ONE YEAR LIMITED WARRANTY

For a period of one (1) year from date of purchase, **ATD Tools, Inc.** will repair or replace, at its option, without charge, any of its products which fails due to a defect in material or workmanship, or which fails to conform to any implied warranty not excluded hereby.

Performance of any obligation under this warranty may be obtained by contacting your distributor or point of sale for further instructions. Please retain your proof of purchase, as it will be needed for any claim.

Except where such limitations and exclusions are specifically prohibited by applicable law, (1) the CONSUMER'S SOLE AND EXCLUSIVE REMEDY SHALL BE THE REPAIR OR REPLACEMENT OF DEFECTIVE PRODUCTS AS DESCRIBED ABOVE, and (2) **ATD Tools, Inc.** SHALL NOT BE LIABLE FOR ANY CONSEQUENTIAL OR INCIDENTAL DAMAGE OR LOSS WHATSOEVER, and (3) THE DURATION OF ANY AND ALL EXPRESSED AND IMPLIED WARRANTIES, INCLUDING WITHOUT LIMITATION, ANY WARRANTIES OF MERCHANTABILITY AND FITNESS FOR A PARTICULAR PURPOSE, IS LIMITED TO A PERIOD OF ONE (1) YEAR FROM DATE OF PURCHASE.

Some states do not allow limitations on how long an implied warranty lasts, so the above limitation may not apply to you. Some states do not allow the exclusion or limitation of incidental or consequential damages, so the above limitation or exclusion may not apply to you. This warranty gives you specific legal rights, and you may also have other rights which vary from state to state.



REPLACEMENT PARTS

Available Parts: Please refer to the Parts drawing when ordering parts. Not all components of the pump are replacement items, but are illustrated as a convenient reference of location and position in the assembly sequence. When ordering parts, give model number, part number and description. Call your distributor current pricing.

Part List for model ATD-5812 (parts drawing is on page 6)

ITEM	PART#	DESCRIPTION	QTY	ITEM	PART#	DESCRIPTION	QTY
1	A57-6-2001-108	Foot pedal	1	41	A57-6-1016-106	Washer	1
2	*	E-clip	2	42	H18-6-8103-104	Special washer	1
3	A57-6-2003-102	Foot pedal axle	1	43	A57-6-1001-204	Base	1
4	D05-6-1001-106	Manifold plug	1	44	A57-6-1605-105	Gasket	1
5	A57-6-3007-105	Noise suppressor	1	45	511-7-0140-200	O-ring	2
6	666-5-0160-107	C-clip	1	46	512-2-0092-101	Compression spring	1
7	*	Back-up ring	2	47	649-1-0040-007	Allen Screw	1
8	*	O-ring	2	48	A57-6-5004-109	Air entrance cap	1
9	A57-6-4002-201	Oil outlet valve	1	49	511-7-0053-104	O-ring	1
10	512-2-0043-108	Compression spring	1	50	A57-6-5001-103	Air entrance base	1
11	601-7-0009-001	Steel ball	1	51	A17-6-1105-103	Plastic cap (air)	1
12	511-7-0410-102	O-ring	1	52	A57-6-5003-107	Air entrance valve	1
13	649-1-0050-055	Allen Screw	6	53	511-7-0080-309	O-ring	1
14	*	Copper washer	6	54	649-1-0050-046	Allen Screw	6
15	A57-6-1603-202	Reservoir top plate	1	55a	A57-3-5007-107	Shipping plug (red)	1
				55b	A57-3-1900-109	Air vent plug (black)	1
16	644-1-0060-05311	Screw	1				
17	503-9-0050-106	Steel ball seat	1	56	512-2-0061-100	Compression spring	1
18	601-7-0006-005	Steel ball	1	57	644-1-0040-204	Screw	1
19	*	Special washer	2	58	*	Compression spring	1
20	A59-6-1017-102	High pressure valve	1	59	503-9-0035-100	Steel ball block	1
				60	601-7-0003-009	Steel ball	1
21	A17-6-1216-102	Valve stem	1				
22	512-2-0067-010	Compression spring	1	61	A57-6-3003-305	Release valve	1
23	A17-5-1603-300	Pressure adjust nut	1	62	A57-6-3004-307	Release valve seat	1
24	601-7-0008-009	Steel ball	1	63	*	O-ring	1
25	A59-6-1015-108	Oil entrance valve	1	64	*	Back-up ring	1
				65	552-2-0010-105	Compression spring	1
26	520-8-0134-101	Filter	1				
27	*	Gasket	1	66	*	Release valve pin	1
28	A57-6-1601-107	Reservoir	1	67	A57-6-3001-112	Release valve guide	1
29	649-1-0060-122	Allen Screw	4	68	*	O-ring	1
30	A57-6-1002-105	Motor cover	1	69	*	Gasket	1
				70	A17-6-1002-103	Noise suppressor	1
31	A17-6-2105-108	Gasket	2				
32	A17-4-2100-500	Air piston assy.	1	71	666-5-0250-108	C-clip	1
33	A57-6-1003-107	Cylinder	1	72	A57-6-4001-209	Oil manifold	1
34	A57-3-1011-108	Piston assy.	1	—	A57-3-9901-101	Repair kit	1
35	512-2-0410-017	Compression spring	1	—	ATD5812-L0	Label (not shown)	1
				—	ATD5812-M0	Manual	1
36	A57-6-1014-102	Piston cover	1				
37	A57-6-2023-108	Bushing	1				
38	573-7-0120-105	Back-up ring	1				
39	*	U-cup	1				
40	A59-6-1013-105	Pump piston	1				

* Repair kit includes 2, 7, 8, 14, 19, 27, 39, 58, 63, 64, 66, 68, 69

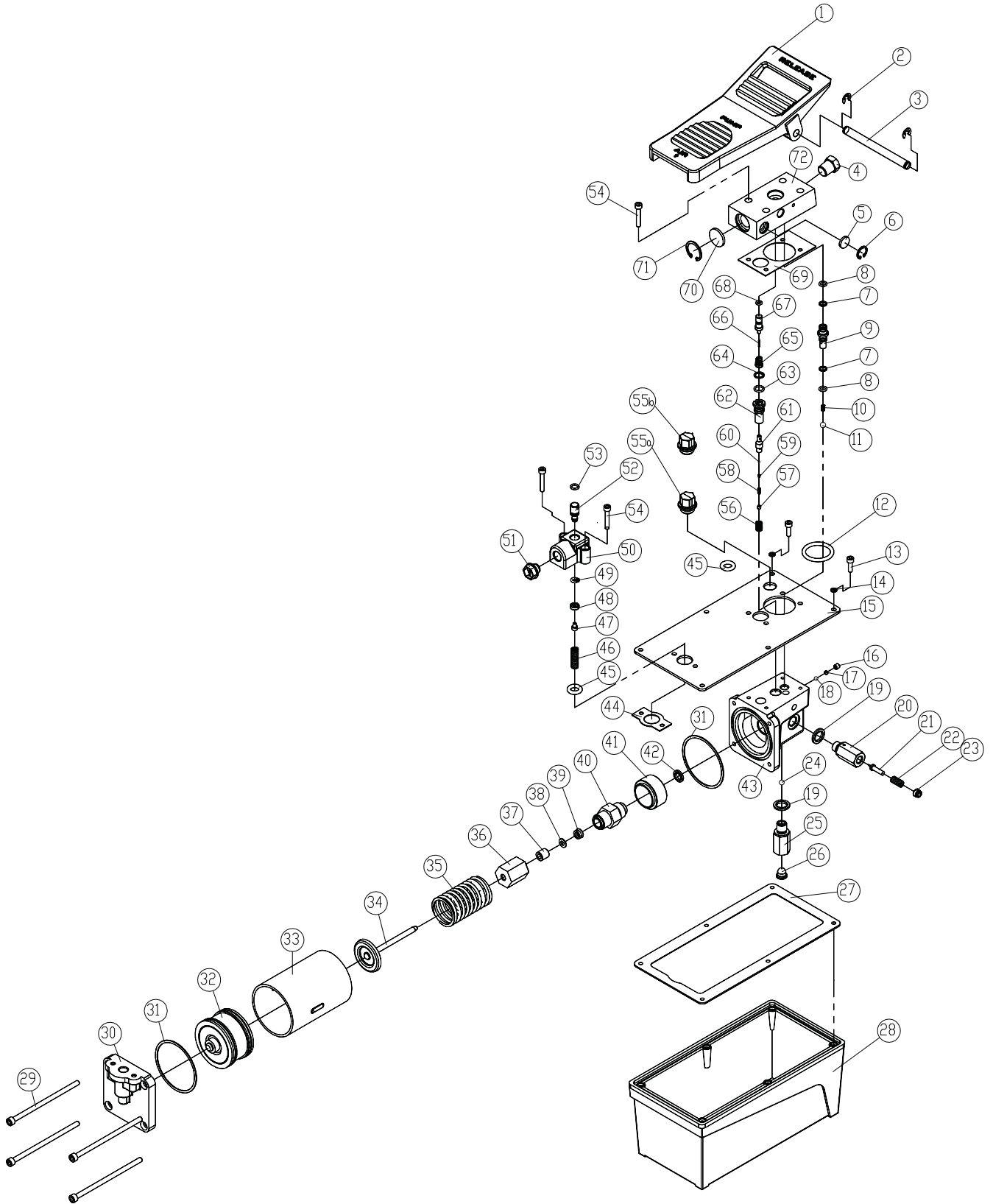

Figure 2- Replacement Parts Illustration for model ATD-5812

Notes

