



ATD-5801 10-Ton Mini Hydraulic Ram Kit Owner's Manual



Features:

- Ideal for tight areas with little clearance
- All steel construction for maximum strength and durability
- (3) extensions can be used individually or together

Specifications:

- Capacity (Ton): 10
- Ram stroke: 1.5"
- Minimum Cylinder Height: 3.5"
- Maximum Cylinder Height: 5"
- Cylinder Effective Area: 2.35 sq. in.

1. SAFETY

To avoid personal injury or property damage, please follow all safety precautions. ATD Tools, Inc. is not responsible for injury or damage resulting from unsafe and incorrect products use or system operation, or lack of maintenance.

 **DANGER** is only used when your action or lack of action may cause serious injury or even death.

 **WARNING** indicates a potential danger that requires correct action to avoid personal injury.

 **IMPORTANT** indicates correct action to prevent damage or equipment failure.

DANGER

- The equipment operator must be qualified, trained and have experience working with hydraulic equipment. Lack of knowledge of this equipment can lead to equipment damage or personal injury.
- Carefully inspect cylinder(s), coupler(s) and hose(s) before using this hydraulic equipment. If you find any damage to the cylinder(s), coupler(s), or hose(s), stop using them immediately and contact your distributor. Damage may cause equipment failure and possible personal injury.
- To avoid personal injury, do not modify or weld hydraulic equipment.
- Never lift a load more than the capacity of the cylinder(s), overloading will cause equipment failure and possible personal injury.
- Cylinder(s) are designed for a maximum pressure of 10,000 psi (700 bar). Do not use a pump or relief valve with a higher pressure rating to connect the cylinders - it could cause equipment failure.
- This cylinder is a load lifting device, not a load holding device. After the load has been raised or lowered, it must always be held mechanically. Never work under a load supported by hydraulic cylinder.
- To avoid personal injury, please keep hands and feet away from cylinder(s) and workplace during operation.
- Do not put poorly balanced or off-center loads on cylinder(s). The incorrect load can result in equipment failure and possible personal injury.

WARNING

- Wear safety glasses, helmet and any other necessary personal protective equipment when operating hydraulic equipment.
- When using this cylinder to lift a load, you should have a solid and level lifting surface for correct support. Be sure to select jack stands that are capable of supporting the load after it has been raised.
- Install pressure gauge in the system to monitor the operating pressure. The gauge must have the same pressure rating as the pump and cylinder(s) in the system. The wrong gauge may cause equipment failure and possible personal injury.
- Carefully inspect the cylinder(s) and coupler(s) before each use. Never connect the cylinder(s) with damaged coupler(s) or damaged port threads. Damaged coupler(s) or damaged port thread(s) may cause equipment failure and possible personal injury.
- To prevent dust or other debris getting into cylinder body or tube, use coupler(s) in a clean place. Dirt or other debris will damage the cylinder's seals and result in premature equipment failure and possible personal injury.
- Cylinder must be placed on a flat base.
- Before removing or tightening hose(s) or coupler(s), release the hydraulic pressure in the system.
- Never handle pressurized hoses; escaping oil under high pressure can penetrate the skin, causing serious injury. Seek medical aid immediately if injured.
- Hydraulic cylinders must use special hydraulic oil, we recommend Mobil DTE13M or equivalent.
- Before lifting, saddle or other accessories must be fully seated in piston. Failure to ensure saddle or other accessory is fully seated can result in damage to hydraulic cylinder and/or severe injury.
- Before lifting, if using external collar threads, ensure that your accessory is completely threaded onto cylinder. Failure to ensure accessory is completely threaded onto cylinder body can result in damage to hydraulic cylinder and/or severe injury.
- For hydraulic technical help or repair service. Please contact your distributor. Manufacturers and distributors have no obligations under any warranty with respect to products that have been repaired by unauthorized personnel, modified, or damaged through misuse, abuse, accident, neglect, or mishandling.

! IMPORTANT

- Keep the cylinder clean at all times.
- When the cylinder is not in use, please keep the piston rod fully retracted, remove hose and use rubber cap(s) to recover the coupler. If you use collar threads, please use the thread protector to cover it.
- Do not drop heavy loads or objects on hose.
- Do not lift and carry hydraulic cylinders by the hose(s) or coupler(s), use the handle or other safe way.
- Use hydraulic equipment in normal temperature, do not use equipment in temperatures of 150°F (65°C) or higher. Overheating softens seals and weakens hose materials, resulting in oil leaking or other equipment failure.

2. SPECIFICATIONS

Model#	Capacity	Stroke	Cylinder Efficient Area	Oil Capacity	Collapsed Height	Extended Height	Internal Pressure	Cylinder Housing Diameter	Ram Plunger Diameter
ATD-5801	10 Tons	1.5"	2.35 sq. in.	3.53 cu. in.	3.5"	5"	10,000 psi	2.75"	1.5"

3. OPERATION

Before using cylinder, please visually check the cylinder and it's parts to make sure there is no damage on cylinder(s), port threads, coupler(s) and hose(s). No oil leaking or shortage of parts. If you find any problem please stop using your equipment immediately and contact with your distributor.

3.1 Set Up

Use a pump with a release valve or a 3-way valve and one hose to connect with Single Acting Cylinder (Figure 1). After connecting all parts, please fully hand-tighten all couplers. If not, oil will leak when you operate the equipment.

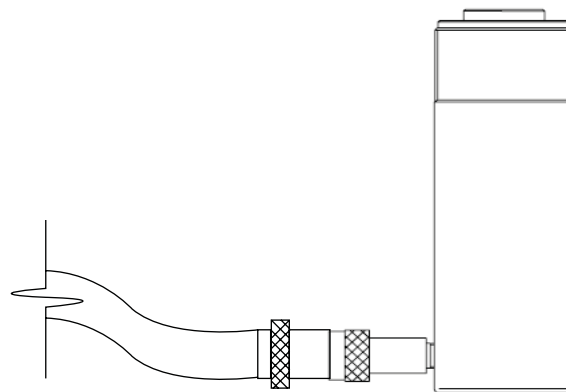

Figure 1

3.2 Bleeding Air from the Cylinder

Air may accumulate within a cylinder during shipment or after prolonged use. Please use the steps below to bleed the air from cylinder.

Position the cylinder as in figure 2, the piston rod is extended down and the cylinder is lower than the pump. Fully extend and retract the cylinder 1 or 2 times. It may be necessary to repeat the above steps several times.

3.3 Operation

- After finishing the steps above, operate the hydraulic pump to advance and retract the cylinder.
- Single acting cylinders use both spring-return and load return.
- Do not allow piston rod to rotate when installing adapters or while operating the cylinder as rotating the piston rod may damage the return spring.
- To reduce wear, use less than full stroke and full capacity when possible.
- After finishing the work, fully return the piston rod, remove hose and use rubber cap(s) to recover the coupler. If you use collar threads, use the thread protector to cover it.

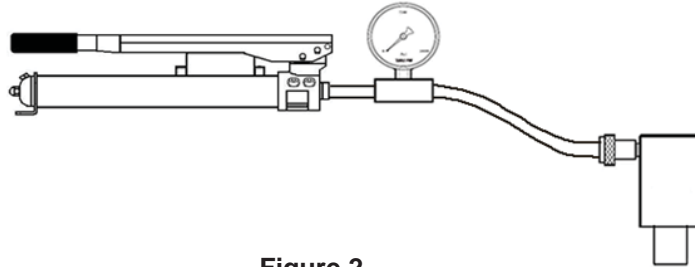

Figure 2

4. MAINTENANCE

4.1 Always use clean, approved hydraulic oil with cylinders. We recommend Mobil DTE-13M or equivalent. Using other unapproved oil or dirty oil will damage the cylinders.

4.2 Always keep cylinder clean, use thread protector and dust cap to protect collar thread and couplers.

4.3 After finishing work, cylinder must be fully retracted, cleaned and stored in ventilated, moisture and corrosion-proof area.

5. TROUBLESHOOTING

Problem	Cause	Solution
Cylinder will not extend or fully extend	<ol style="list-style-type: none"> 1. Release valve open 2. Couplers not fully tightened 3. Oil level in pump reservoir is low 4. Pump or valve malfunctioning 5. Overload for cylinder 6. Cylinder piston rod binding 	<ol style="list-style-type: none"> 1. Fully tighten pump release valve 2. Fully tighten couplers 3. Fill oil in pump 4. Repair or use another pump and valve 5. Change another cylinder with appropriate capacity 6. Check for dirt or leaks, change the damage parts
Cylinder can not maintain pressure	<ol style="list-style-type: none"> 1. Leaky connection 2. Cylinder seals damage 3. Release valve not fully closed 4. Pump or valve malfunctioning 	<ol style="list-style-type: none"> 1. Clean and reseal thread, tighten connection 2. Replace worn seals. Clean inside cylinder and use clean hydraulic oil 3. Fully tightening the release valve 4. Repair, or use another pump and valve
Cylinder extends slower than normal	<ol style="list-style-type: none"> 1. Leaky connection 2. Coupler not fully tightened 3. Pump malfunctioning 	<ol style="list-style-type: none"> 1. Clean and reseal thread, tighten connection 2. Fully tighten couplers 3. Repair or use another pump and valve
Cylinder dithers when extended	<ol style="list-style-type: none"> 1. Air in cylinder 2. Cylinder piston rod binding 	<ol style="list-style-type: none"> 1. Bleed air (see chapter 2.2) 2. Check for dirt or leaks, Check for bent, misaligned and worn parts
Cylinder leaks hydraulic oil	<ol style="list-style-type: none"> 1. Leaky connection 2. Worn or damaged seals 3. Cylinder damage 	<ol style="list-style-type: none"> 1. Clean and reseal thread, tighten connection 2. Replace worn seals, clean inside cylinder and use clean hydraulic oil 3. Use new cylinder or contact your distributor for repair information
Cylinder will not retract or retracts slower than normal	<ol style="list-style-type: none"> 1. Pump release valve closed 2. Couplers are not fully tightened 3. Pump reservoir is full 4. Hose is blocked 5. Return spring is damaged 6. Cylinder damaged 	<ol style="list-style-type: none"> 1. Open release valve 2. Tighten the couplers 3. Drain hydraulic oil to correct level 4. Clean or change hose 5. Change return spring 6. Use new cylinder or contact your distributor for repair information

REPLACEMENT PARTS:

Please refer to the Parts drawing when ordering parts. Not all components of the cylinder are replacement items but are illustrated as a convenient reference of location and position in the assembly sequence. When ordering parts from your distributor, give model number and part number as shown below. Contact your distributor for current pricing.

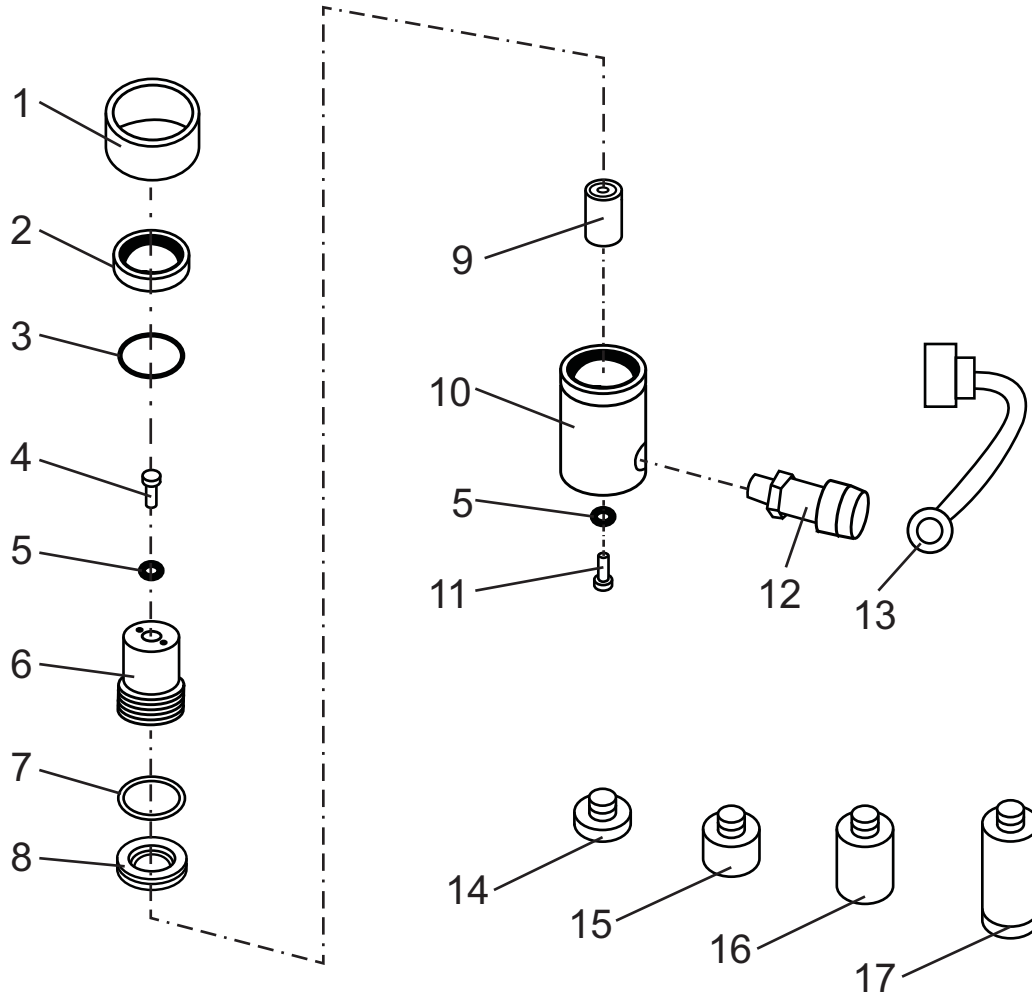

ITEM#	ORDERING PART#	PART DESCRIPTION	QTY
1	PRT5801-01	TOP BUSHING	1
2	PRT5801-02	BUSHING	1
3	PRT5801-03	DUST PROOF RING	1
4	PRT5801-04	BOLT	1
5	PRT5801-05	COUPLER WASHER	1
6	PRT5801-06	RAM	1
7	PRT5801-07	BLOCK RING	1
8	PRT5801-08	Y-RING	1
9	PRT5801-09	SPRING	1

ITEM#	ORDERING PART#	PART DESCRIPTION	QTY
10	PRT5801-10	CYLINDER ASSEMBLY	1
11	PRT5801-11	BOLT	1
12	PRT5801-12	FEMALE COUPLER	1
13	PRT5801-13	DUST PROOF PLUG	1
14	PRT5801-14	ADAPTER SADDLE 10MM	1
15	PRT5801-15	ADAPTER SADDLE 25MM	1
16	PRT5801-16	ADAPTER SADDLE 50MM	1
17	PRT5801-17	ADAPTER SADDLE WITH SCREW	1
N/S	PRT5801-SK	CYLINDER SEAL KIT*	1

*CYLINDER REPAIR KIT INCLUDES 3, 5, 7 & 8



ATD[®]

WARRANTY

1 YEAR LIMITED WARRANTY

THIS WARRANTY AND CONFIRMED RECEIPT(S) SHOULD BE RETAINED BY THE CUSTOMER AT ALL TIMES

PURCHASED FROM: _____

DATE PURCHASED: _____

INVOICE/RECEIPT NUMBER: _____

Your ATD-5801 is warranted for a period of 12 months from the original purchase date.

For a period of one (1) year from your purchase date, ATD Tools Inc. will repair or replace (at its option) without charge, your ATD product if it was purchased new and the product has failed due to a defect in material or workmanship which you experienced during normal use of the product. This limited warranty is your exclusive remedy.

To access the benefits of this warranty, contact your supplier, or point of sale directly. You may be advised to return the product under warranty, freight prepaid, to your supplier for warranty determination.

If this ATD product is altered, abused, misused, modified, or undergoes service by an unauthorized technician, your warranty will be void. We are not responsible for damage to ornamental designs you place on this ATD product and such ornamentation should not cover any warnings or instructions or they may void the warranty. This warranty does not cover scratches, superficial dents, and other abrasions to the paint finish that occur under normal use. It also does not cover normal wear items such as but not limited to brushes, batteries, drill bits, drill chucks, pads or blades.

Subject to the law in your state:

- (1) Your sole and exclusive remedy is repair or replacement of the defective product as described above.
- (2) ATD is not liable for any incidental damages, including but not limited to, lost profits and unforeseeable consequences.
- (3) The repair and replacement of this product under the express limited warranty described above is your exclusive remedy and is provided in lieu of all other warranties, express or implied. All other warranties, including implied warranties and warranties of merchantability or fitness for a particular purpose are disclaimed and, if disclaimer is prohibited, these warranties are limited to one year from your date of purchase of this product.

Some states' laws do not allow limited durations on certain implied warranties and some states' laws do not allow limitations on incidental or consequential damages. You should consult the law in your state to determine how your rights may vary.

[Affix receipt or invoice here for safe keeping]