



ATD-5800A / ATD-5810A 4-Ton and 10-Ton Body Repair Kit Owner's Manual



Features:

- Designed for pushing, spreading and pressing of vehicle body panels as well as various component parts and assemblies
- Auto bleeding pump with pressure gauge (ATD-5800A)
- Double speed and auto bleeding pump with pressure gauge (ATD-5810A)
- Heavy-duty case allows for easy storage and transport for use in shop or on the road
- Meets or exceeds ASME/PASE 2014 standards

ATD-5800A Specifications:

- Ram Capacity (Tons): 4
- Pump Capacity (psi): 8,000
- Ram – Closed Height: 10.5"
- Ram – Extended Height: 15.2"
- Ram Effective Area: 1.1 sq. in.
- Weight: 44 lbs

ATD-5810A Specifications:

- Ram Capacity (Tons): 10
- Pump Capacity (psi): 10,000
- Ram – Closed Height: 12.7"
- Ram – Extended Height: 17.8"
- Ram Effective Area: 2.46 sq in
- Weight: 73.7 lbs

Save these instructions. For your safety, read and understand the information contained within. The owner and operator shall have an understanding of this product and safe operating procedures before attempting to use this product. Instructions and Safety information shall be conveyed in the operators native language before use of this product is authorized. Make certain that the operator thoroughly understands the inherent dangers associated with the use and misuse of the product. If any doubt exists as to the safe and proper use of this product as outlined in this factory authorized manual, remove from service. **Inspect before each use.** Do not use if broken, bent, cracked or otherwise damaged parts are noted. If any component of this product has been or suspected to have been subjected to a shock load (a load dropped suddenly, unexpectedly upon it), discontinue use until checked by a factory authorized service center (contact distributor or manufacturer for a list of authorized service centers). Owners and operators of this equipment shall be aware that the use and subsequent repair of this equipment may require special training and knowledge. It is recommended that an annual inspection be done by qualified personnel and that any missing or damaged parts, decals, warning/safety labels or signs be replaced with factory authorized replacement parts only. Any component of this Body Repair Kit that appears to be damaged in any way, is worn or operates abnormally shall be removed from service immediately until such time as it can be repaired or replaced.

PRODUCT DESCRIPTION

ATD Tools Hydraulic Body Repair Kits are designed to be used for pushing, spreading, and pressing of vehicle body panels as well as various component parts and assemblies. A variety of attachments are included.

WARNING: when extension tubes and/or offset attachments are used, the rated capacity is always reduced by 50 % for each tube or offset attachment connected. See Parts Section on page 7 & 8 for identification of "offset" attachments.

SPECIFICATIONS

Model	Pump Capacity	Ram Capacity	Ram		Ram Effective Area	Weight
			Closed Height	Extended Height		
ATD-5800A	8,000 psi	4 Ton	10.5"	15.2"	1.1 sq. in.	44 lbs.
ATD-5810A	10,000 psi	10 Ton	12.7"	17.8"	2.46 sq. in.	73.7 lbs.

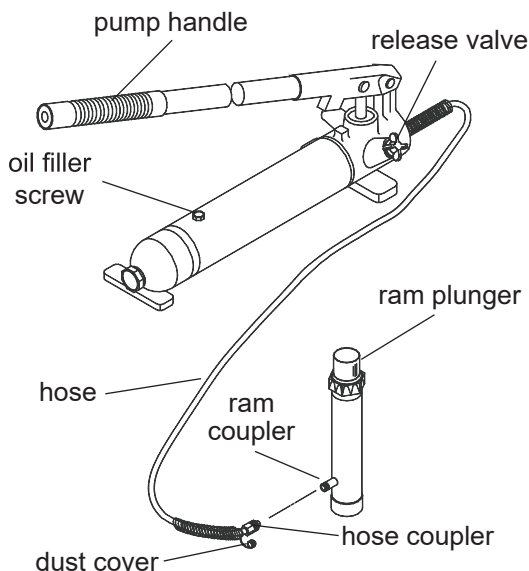

Figure 1 - ATD-5800A and ATD-5810A nomenclature

BEFORE USE

1. Before using this product, read the owner's manual completely and familiarize yourself thoroughly with the product, its components and recognize the hazards associated with its use.
2. Inspect before each use. Do not use if bent, broken, leaking or damaged components are noted.
3. Check to ensure that all parts of your kit are included (see illustration and parts list).
4. Carefully remove the dust caps and plugs from hose coupler and ram coupler.
5. Connect hose coupler to ram coupler, ensure that there are no fluid leaks.
6. Locate and open release valve. Close release valve clockwise and pump handle until ram is fully extended, then open release valve counter-clockwise until ram has fully retracted.
7. With ram fully retracted and release valve open, place pump in horizontal position. Locate and open oil filler screw (on reservoir body, near the back). This will release air trapped within the reservoir. Retighten the oil filler screw.
8. If using with air actuated units, an air source of at least 7.8 CFM @ 90 psi is required.

GENERAL SAFETY INFORMATION

1. Ensure that attachments are fully engaged before applying load.
2. Ensure that load is centrally applied to attachment or ram saddle. Do not load off center.
3. If bowing or bending of ram or any attachment occurs during use, **"STOP"**, release pressure immediately and reconsider application. Application may not be compatible with product, a ram kit with a higher capacity may be needed.

OPERATION

Note: Inspect before each use for evidence of fluid leaks, damaged hydraulic fittings, bent or broken attachments and missing parts.

1. Locate and close release valve by turning it clockwise until firmly closed. (Do not over tighten)
2. Operate by pumping handle. This will send fluid from the pump reservoir into the high pressure hose assembly and into the ram assembly.
3. Continue pumping until ram reaches desired position.

Note: Pump may be used in horizontal and vertical position as illustrated (See figure. 2).

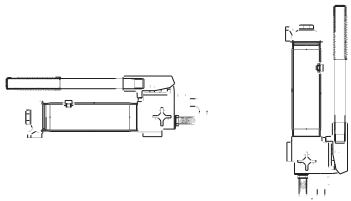

Figure 2 - Horizontal and Vertical position

To Release Pressure on work piece:

Slowly, carefully turn the release valve counter-clockwise until ram retracts to desired position. **Never turn release valve more than 1/2 of a full turn.** The ram return system is spring loaded and the release valve system is metered, allowing controlled retraction of the ram.

! DANGER

- If oil leakage is detected, discontinue use of the ram immediately and contact your nearest authorized Service Center. The ram could develop excessive pressure and cause the ram, hose or coupler to burst, which could cause serious injury or death.

! WARNING



To avoid crushing and related injuries:
NEVER work on, under or around a lifted load before it is properly supported by appropriate mechanical means such as jack stands. Never rely on hydraulic pressure alone to support load.



Wear protective clothing and safety goggles to reduce the risk of injection.

! WARNING

- All WARNING statements must be carefully observed to help prevent personal injury.
- Do not exceed rated capacity.
- Use only on hard, level surfaces capable of sustaining rated capacity loads.
- Do not open oil filler screw unless ram is fully retracted.
- Do not wear sandals and jewelry when operating this equipment.
- Do not use as a vehicle lifting device or vehicle support.
- Any attachment that is not loaded centrally, as through the centerline of the ram, is considered to be "offset".
- When extension tubes and/or offset attachments are used, the rated capacity is always reduced by 50% for each tube or attachment connected.
- Monitor pressure and load at all times.
- Always verify load with calibrated load cell and indicator, known good pressure gauge or equivalent devices.
- Do not modify this device.
- Failure to heed these markings may result in personal injury and/or property damage.

! WARNING

Hydraulic Hoses and Fluid Transmission Lines

- Avoid short runs of straight line tubing. Straight line runs do not provide for expansion and contraction due to pressure and/or temperature changes.
- Reduce stress in tube lines. Long tubing runs should be supported by brackets or clips. Before operating the pump, all hose connections must be tightened with the proper tools. Do not overtighten. Connections should only be tightened securely and leak-free. Overtightening can cause premature thread failure or high pressure fittings to burst.
- Should a hydraulic hose ever rupture, burst or need to be disconnected, immediately shut off the pump and release all pressure. Never attempt to grasp a leaking pressurized hose with your hands. The force of escaping hydraulic fluid can inflict injury.
- Do not subject the hose to potential hazard such as fire, sharp objects, extreme heat or cold, or heavy impact.
- Do not allow the hose to kink, twist, curl, crush, cut or bend so tightly that the fluid flow within the hose is blocked or reduced. Periodically inspect the hose for wear, because any of these conditions can damage the hose and possibly result in personal injury.
- Do not pull, position or move setup by the hose. Doing so can damage the hose and possibly cause personal injury.
- Hose material and coupler seals must be compatible with hydraulic fluid used. Hoses also must not come in contact with corrosive materials such as battery acid, creosote-impregnated objects and wet paint. Hose deterioration due to corrosive material can result in personal injury. Never paint a coupler or hose.
- The user must be a qualified operator familiar with the correct operation, maintenance, and use of rams. Lack of knowledge in any of these areas can lead to personal injury.
- Use only approved accessories and approved hydraulic fluid.
- Do not exceed the rated capacity of the ram.
- Inspect each ram and coupler before each use to prevent unsafe conditions from developing.
- Do not use rams if they are damaged, altered or in poor condition.
- Do not use rams with bent or damaged coupler or damaged threads.
- Under certain conditions, the use of an extension with a hydraulic ram may not be advisable and could present a dangerous condition.

! WARNING

- Avoid pinch points or crush points that can be created by the load or parts of ram.
- To help prevent material fatigue if the ram is to be used in a continuous application, the load should not exceed 85% of the rated capacity.
- Ram must be on a stable base which is able to support the load while pushing or lifting.
- Ensure ram is fully engaged into/onto adapters, extension accessories.
- To help prevent personal injury, use shims, friction material or constraints to prevent slippage of the base or load.
- Do not off-center loads on a ram.
The load can tip or the ram can “kick out” and cause personal injury.

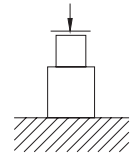

Center loads on ram

- As the load is lifted, use blocking and cribbing to guard against a falling load.
- Never allow personnel to work on, under or around a load before it is properly supported by appropriate mechanical means. Never rely on hydraulic pressure alone to support load.
- All personnel must be clear before lowering.
- Never try to disassemble a hydraulic cylinder. Refer repairs to qualified, authorized personnel.

IMPORTANT

- Keep ram clean at all times.
- When the ram is not in use, keep the piston(s) fully retracted.
- Use an approved, high-grade pipe thread sealant to seal all hydraulic connections. Teflon tape can be used if only one layer of tape is used and it is applied carefully (two threads back) to prevent the tape from being introduced into hydraulic system. A piece of tape could travel through the system and obstruct the flow of fluid and adversely affect function.
- Never attach ANY component not authorized by manufacturer.
- Never use other than factory provided and/or authorized fasteners.

KNOW YOUR SYSTEM

Your ram, hose(s), couplings and pump all must be rated for the same maximum operating pressure, correctly connected and compatible with the hydraulic fluid used. An improperly matched system can cause the system to fail and possibly cause serious injury.

Basic Setup

The capacity of the body repair kit can be significantly affected by the number of attachments used and the type of load applied. The approximate load capacity of each function setup is illustrated below. When two or more extension tubes are used together, be sure to position the shortest tube further away from the ram.

A. Push

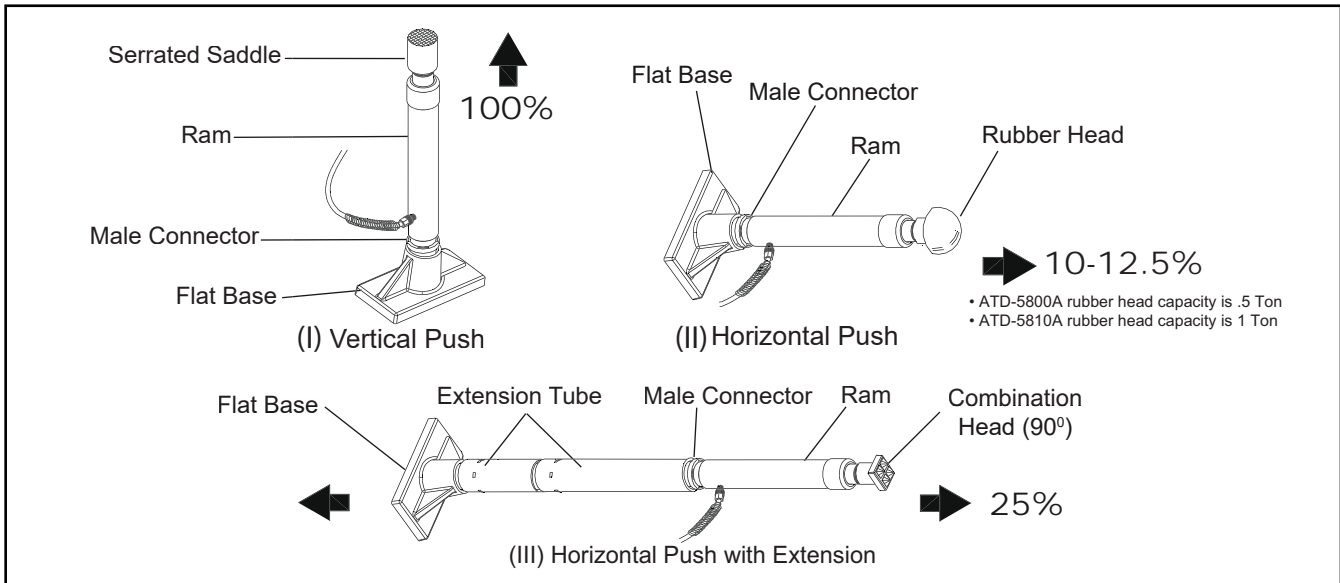

B. Spread

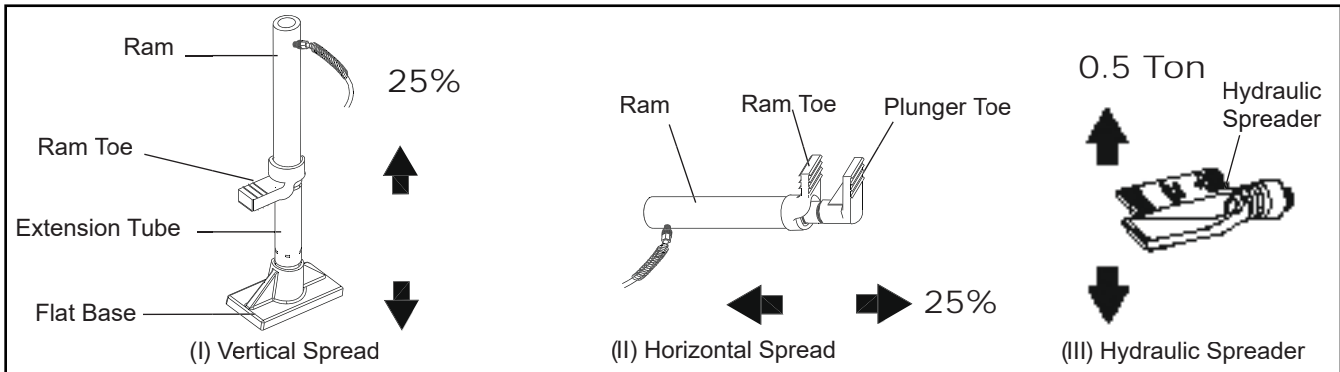

MAINTENANCE

Important: Use only a good grade hydraulic jack oil. Avoid mixing different types of fluid and Never use brake fluid, turbine oil, transmission fluid, motor oil or glycerin. Improper fluid can cause premature failure of the ram and the potential for sudden and immediate loss of load. We recommend Mobil DTE 13M or equivalent.

Adding oil

1. With ram fully lowered, set pump unit in its normal, level position. Locate and remove oil filler screw.
2. Fill until oil is within 3/4" of the oil filler screw hole opening, re-install oil filler screw.

Changing oil

For best performance and increased system life, replace the complete fluid supply at least once per year.

1. With ram fully lowered, remove the oil filler screw from the pump reservoir as above.
2. Lay the pump on its side and drain the fluid into a suitable container.

Note: Dispose of hydraulic fluid in accordance with local regulations.

3. Set pump in its level upright position.
4. Fill with good quality jack oil to within 3/4" of the oil filler screw hole opening. Reinstall oil filler screw.

Lubrication

A coating of light lubricating oil to pivot points and hinges will help to prevent rust and assure that pump assemblies move freely.

Cleaning

Periodically check the pump piston and ram for signs of rust or corrosion. Clean as needed and wipe with an oily cloth.

Note: Never use sandpaper or abrasive material on these surfaces!

Storage

When not in use, store with the pump piston and ram fully retracted.

TROUBLESHOOTING GUIDE

The following information is intended as an aid in determining if problem exists.

Symptom	Possible Causes	Corrective Action
Ram will not extend, or respond to pressurized fluid	<ul style="list-style-type: none">• Overload condition.• Release valve not closed.	<ul style="list-style-type: none">• Remedy overload condition.• Ensure release valve closed.
Ram responds to pressurized fluid, but system does not maintain pressure	<ul style="list-style-type: none">• Overload condition.• Release valve not closed.• Hydraulic unit malfunction.	<ul style="list-style-type: none">• Remedy overload condition.• Ensure release valve closed.• Contact your supplier for parts.
Ram will not return fluid to pump	<ul style="list-style-type: none">• Malfunctioning coupler, damaged application.• Reservoir overfilled.	<ul style="list-style-type: none">• Secure load by other means. Open release valve, depressurize pump and hose, remove application and replace coupler.• Secure load by other means. Open release valve, depressurize pump and hose, remove application, then drain fluid to proper level.
Ram will not fully extend (cylinder or spreader)	<ul style="list-style-type: none">• Fluid level low.	<ul style="list-style-type: none">• Secure load by other means. Open release valve, depressurize pump and hose, remove application, then add fluid to proper level.
Poor performance	<ul style="list-style-type: none">• Fluid level low.• Air trapped in system.	<ul style="list-style-type: none">• Ensure proper fluid level.• Vent the sytem (refer to figure 3)

How to bleed air from system

1. Bleed air from ram: Place pump at a higher elevation than the hose and ram as shown in figure 3 below. The objective is to float the air bubbles up hill and back to the reservoir where they belong. Close valve and extend ram as fas as possible. Open valve fully allowing oil and air to return to reservoir. Repeat this procedure two or three times will do the trick.
2. Bleed air from pump: With ram fully retracted, remove oil filler screw to let pressurized air escape, then reinstall oil filler screw.

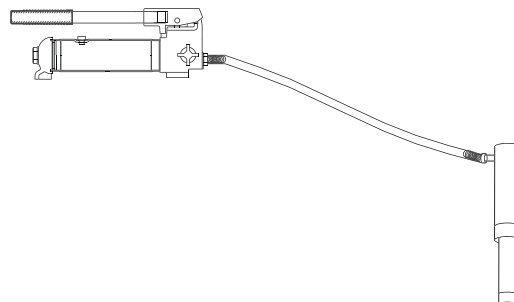
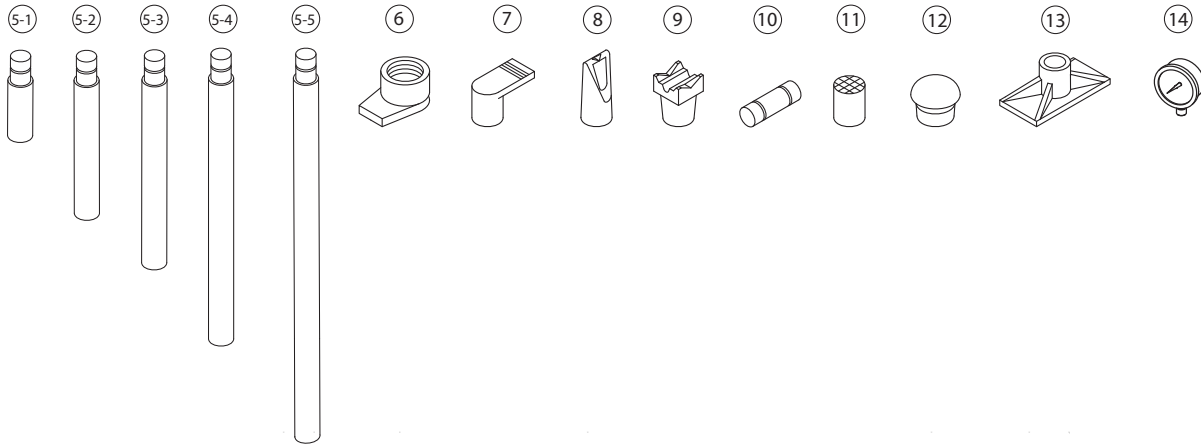
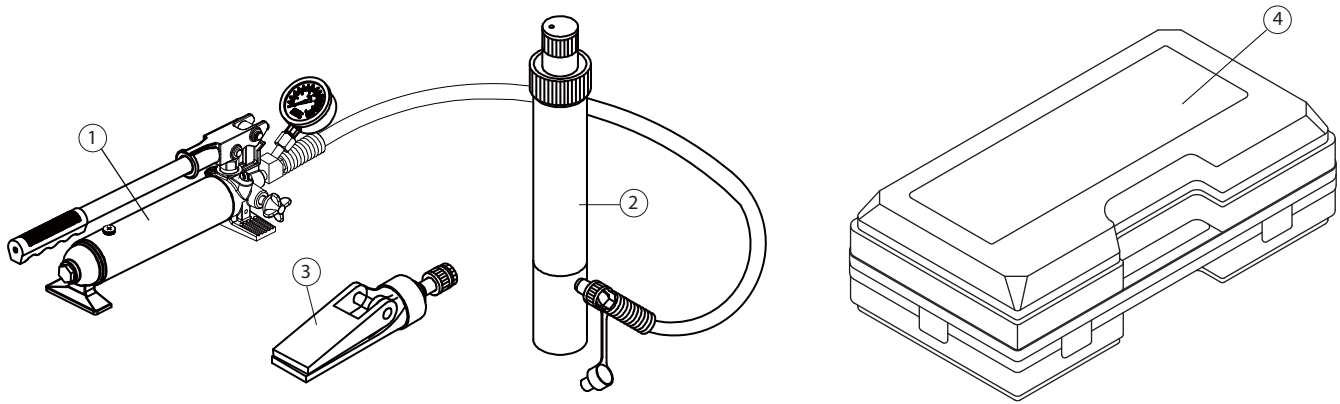

Figure 3 - Pump and ram illustration to bleed air

REPLACEMENT PARTS

Not all components of this product are replacement items, but are illustrated as a convenient reference for position in the assembly sequence. When ordering parts, give model number, part number and description. Call your distributor for current pricing:

Model ATD-5800A



ITEM#	ORDERING PART#	PART DESCRIPTION	QTY
1	PRT5800A-01	PUMP	1
2	PRT5800A-02	RAM	1
3	PRT5800A-03	SPREADER	1
4	PRT5800A-04	CASE	1
5-1	PRT5800A-51	EXTENSION TUBE - 3.23" (82mm)	1
5-2	PRT5800A-52	EXTENSION TUBE - 5.04" (128mm)	1
5-3	PRT5800A-53	EXTENSION TUBE - 8.5" (216mm)	1
5-4	PRT5800A-54	EXTENSION TUBE - 16.54" (420mm)	1
5-5	PRT5800A-55	EXTENSION TUBE - 19.49" (495mm)	1
6	PRT5800A-06	RAM TOE	1
7	PRT5800A-07	PLUNGER TOE	1
8	PRT5800A-08	WEDGE HEAD	1
9	PRT5800A-09	V-BASE	1
10	PRT5800A-10	ADAPTERS	1
11	PRT5800A-11	SERRATED SADDLE	1
12	PRT5800A-12	RUBBER HEAD	1
13	PRT5800A-13	BASE	1
14	PRT5800A-P38	GAUGE	1

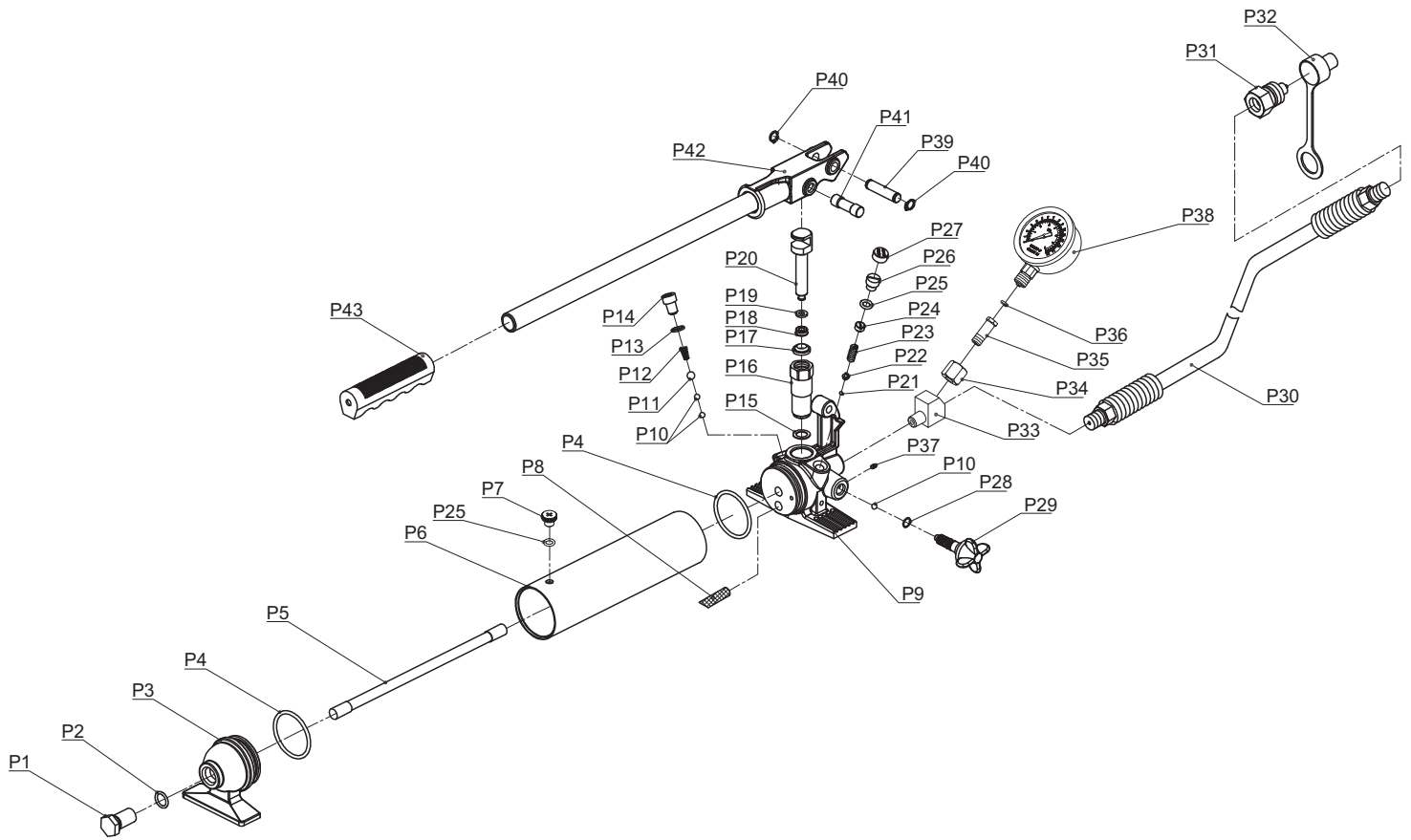

ITEM#	ORDERING PART#	PART DESCRIPTION	QTY
P1	PRT5800A-P1	SCREW	1
P2	PRT5800A-P2	O-RING	1
P3	PRT5800A-P3	CAP	1
P4	PRT5800A-P4	O-RING	2
P5	PRT5800A-P5	TIE ROD	1
P6	PRT5800A-P6	RESERVOIR	1
P7	PRT5800A-P7	SCREW	1
P8	PRT5800A-P8	FILTER	1
P9	PRT5800A-P9	PUMP	1
P10	PRT5800A-P10	STEEL BALL	3
P11	PRT5800A-P11	STEEL BALL	1
P12	PRT5800A-P12	SPRING	1
P13	PRT5800A-P13	COPPER RING	1
P14	PRT5800A-P14	SCREW	1
P15	PRT5800A-P15	COPPER RING	1
P16	PRT5800A-P16	PISTON SEAT	1
P17	PRT5800A-P17	DUST RING	1
P18	PRT5800A-P18	U-RING	1
P19	PRT5800A-P19	SEAL RING	1
P20	PRT5800A-P20	PISTON	1
P21	PRT5800A-P21	STEEL BALL	1
P22	PRT5800A-P22	BALL SEAT	1
P23	PRT5800A-P23	SPRING	1
P24	PRT5800A-P24	SCREW	1

ITEM#	ORDERING PART#	PART DESCRIPTION	QTY
P25	PRT5800A-P25	O-RING	2
P26	PRT5800A-P26	SCREW	1
P27	PRT5800A-P27	CAP	1
P28	PRT5800A-P28	O-RING	1
P29	PRT5800A-P28-29	RELEASE VALVE	1
P30	PRT5800A-P30	HOSE	1
P31	PRT5800A-P31	COUPLER	1
P32	PRT5800A-P32	DUST COVER	1
P33	PRT5800A-P33	CONNECTOR	1
P34	PRT5800A-P34	NUT	1
P35	PRT5800A-P35	CONNECTOR	1
P36	PRT5800A-P36	O-RING	1
P37	PRT5800A-P37	SCREW	1
P38	PRT5800A-P38	PRESSURE GAUGE	1
P39	PRT5800A-P39	PIN	1
P40	PRT5800A-P40	CIRCLIP	2
P41	PRT5800A-P41	PIN	1
P42	PRT5800A-P42	HANDLE	1
P43	PRT5800A-P43	HANDLE GRIP	1
N/S	PRT5800A-SK	SEAL KIT*	1
N/S	PRT5800A-P39-41	PIN SET (Includes P39 & P41)	1
N/S	PRT5800A-P15-20	PISTON AND PISTON SEAT**	1

* - Seal Kit Includes: P2, P4, P13, P15, P17, P18, P19, P25, P28, P36, R06, R07, SP07, SP08, SP12/R16, & SP13/R17

** - Piston and Piston Seat includes: P15, P16, P17, P18, P19, P20

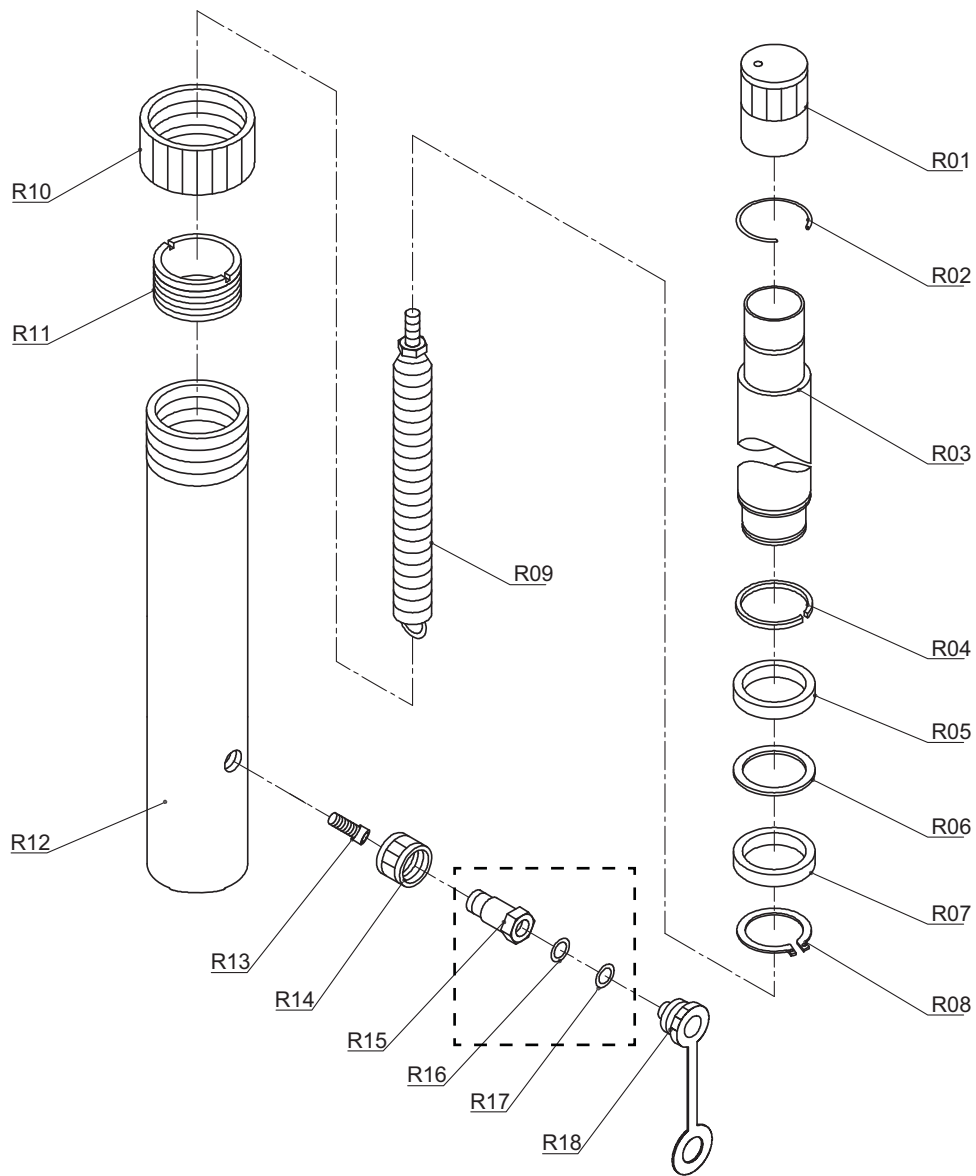

ITEM#	ORDERING PART#	PART DESCRIPTION	QTY
R01	PRT5800A-R01	COVER	1
R02	PRT5800A-R02	RETAINING RING	1
R03	PRT5800A-R03	PISTON ROD	1
R04	PRT5800A-R04	RETAINING RING	1
R05	PRT5800A-R05	WASHER	1
R06	PRT5800A-R06	SEAL RING	1
R07	PRT5800A-R07	U-RING	1
R08	PRT5800A-R08	SNAP RING	1
R09	PRT5800A-R09	SPRING	1
R10	PRT5800A-R10	COVER	1
R11	PRT5800A-R11	LIMIT RING	1
R12	PRT5800A-R12	CYLINDER	1
R13	PRT5800A-R13	SCREW	1
R14	PRT5800A-R14	NUT	1
R15	PRT5800A-SP11-1	COUPLER	1
R16	PRT5800A-SP11-1	O-RING	1
R17	PRT5800A-SP11-1	SEAL RING	1
R18	PRT5800A-R18	DUST CAP	1

* PRT5800A-SP11-1 connector includes R15, R16 & R17

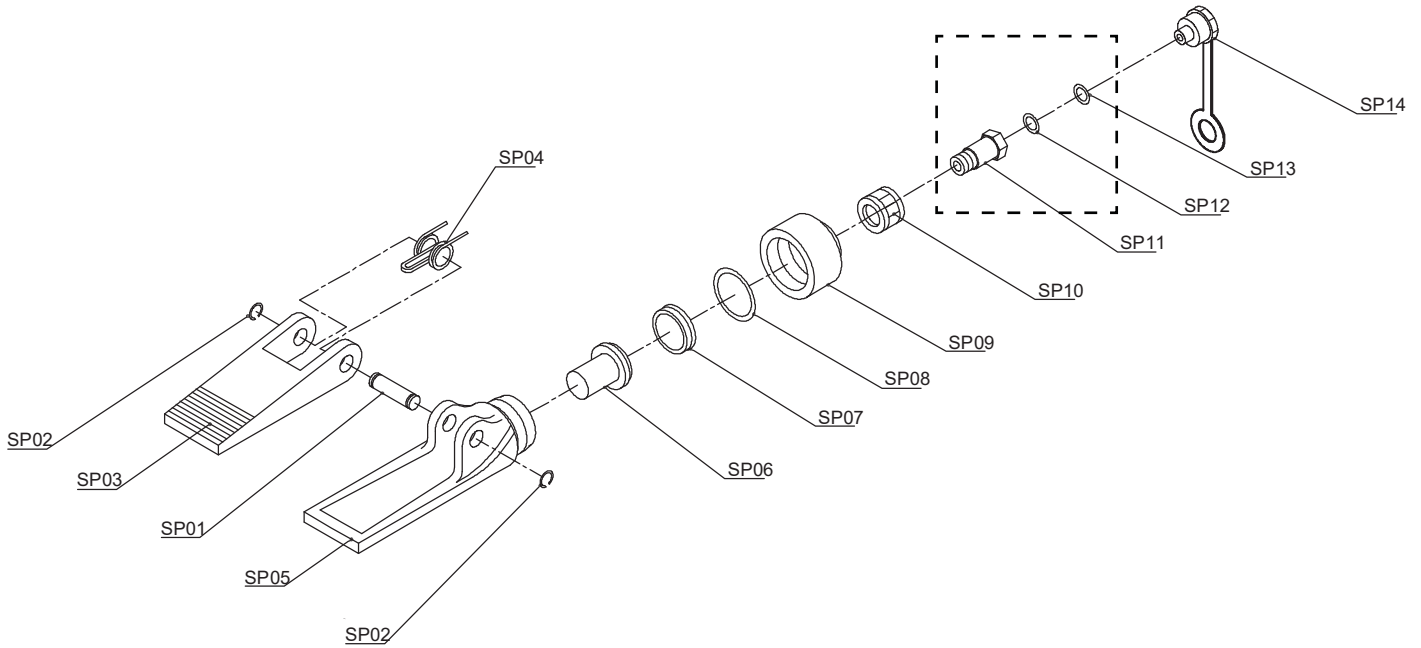

ITEM#	ORDERING PART#	PART DESCRIPTION	QTY
SP1	PRT5800A-SP1	PIN	1
SP2	PRT5800A-SP2	RETAINING RING	1
SP3	PRT5800A-SP3	MOVABLE JAW	1
SP4	PRT5800A-SP4	SPRING	1
SP5	PRT5800A-SP5	FIXED JAW	1
SP6	PRT5800A-SP6	PISTON	1
SP7	PRT5800A-SP7	SEAL RING	1
SP8	PRT5800A-SP8	O-RING	1
SP9	PRT5800A-SP9	END CAP	1
SP10	PRT5800A-SP10	NUT	1
SP11	PRT5800A-SP11-1	CONNECTOR	1
SP12	PRT5800A-SP11-1	O-RING	1
SP13	PRT5800A-SP11-1	SEAL RING	1
SP14	PRT5800A-SP14	DUST CAP	1

* PRT5800A-SP11-1 connector includes SP11, SP12 & SP13

REPLACEMENT PARTS

Not all components of this product are replacement items, but are illustrated as a convenient reference for position in the assembly sequence. When ordering parts, give model number, part number and description. Call your distributor for current pricing:

Model ATD-5810A

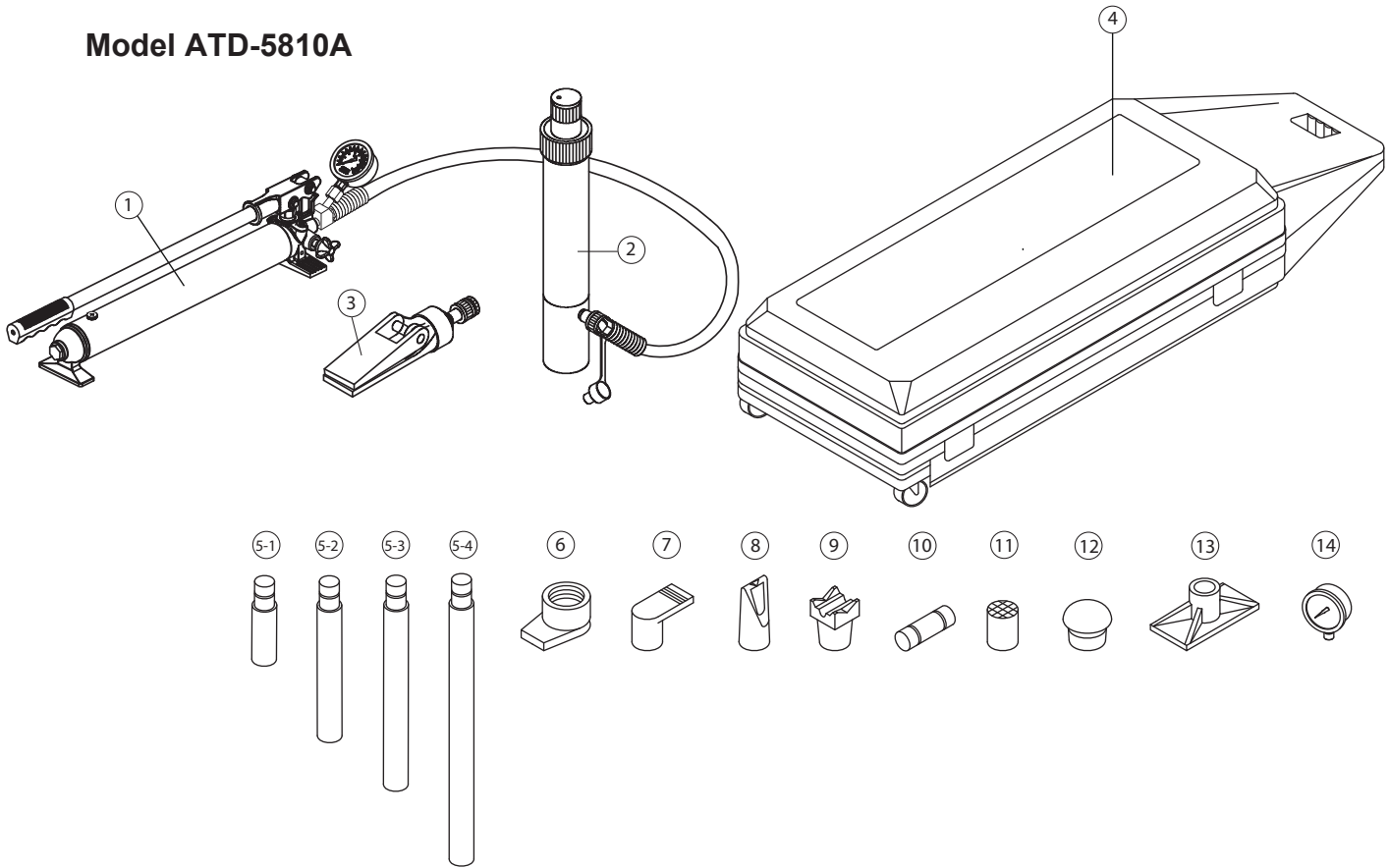

ITEM#	ORDERING PART#	PART DESCRIPTION	QTY
1	PRT5810A-01	PUMP	1
2	PRT5810A-02	RAM	1
3	PRT5800A-03	SPREADER	1
4	PRT5810A-04	CASE	1
5-1	PRT5810A-51	EXTENSION TUBE - 4.33" (110mm)	1
5-2	PRT5810A-52	EXTENSION TUBE - 10.43" (265mm)	1
5-3	PRT5810A-53	EXTENSION TUBE - 14.37" (365mm)	1
5-4	PRT5810A-54	EXTENSION TUBE - 20.47" (520mm)	1
6	PRT5810A-06	RAM TOE	1
7	PRT5810A-07	PLUNGER TOE	1
8	PRT5810A-08	WEDGE HEAD	1
9	PRT5810A-09	V-BASE	1
10	PRT5810A-10	ADAPTER	1
11	PRT5810A-11	SERRATED SADDLE	1
12	PRT5810A-12	RUBBER HEAD	1
13	PRT5810A-13	BASE	1
14	PRT5800A-P38	GAUGE	1

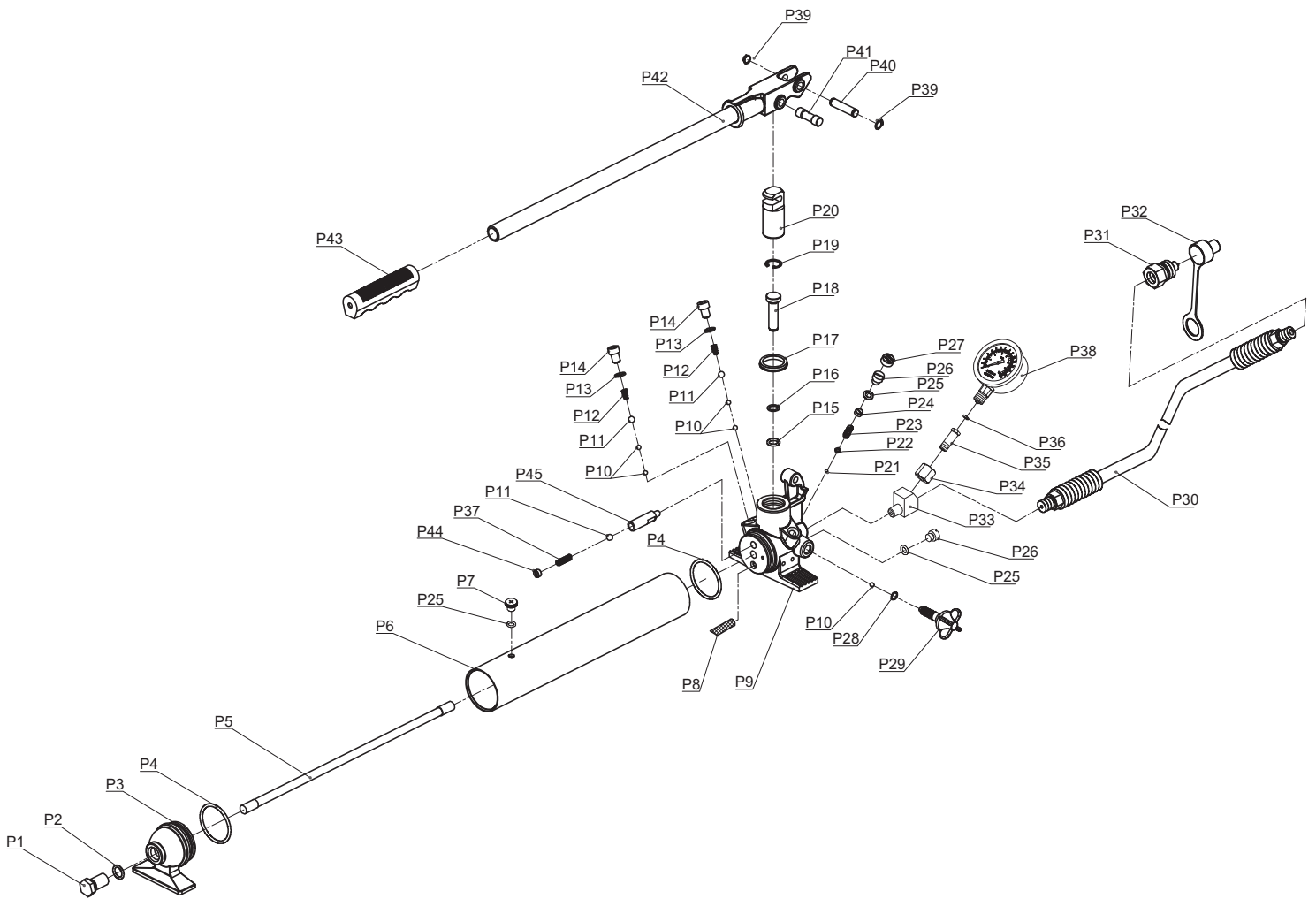

ITEM#	ORDERING PART#	PART DESCRIPTION	QTY
P1	PRT5810A-P1	SCREW	1
P2	PRT5810A-P2	O-RING	1
P3	PRT5810A-P3	CAP	1
P4	PRT5810A-P4	O-RING	2
P5	PRT5810A-P5	TIE ROD	1
P6	PRT5810A-P6	RESERVOIR	1
P7	PRT5810A-P7	SCREW	1
P8	PRT5810A-P8	FILTER	1
P9	PRT5810A-P9	PUMP	1
P10	PRT5810A-P10	STEEL BALL	5
P11	PRT5810A-P11	STEEL BALL	3
P12	PRT5810A-P12	SPRING	2
P13	PRT5810A-P13	WASHER	2
P14	PRT5810A-P14	SCREW	2
P15	PRT5810A-P15	O-RING	1
P16	PRT5810A-P16	SEAL RING	1
P17	PRT5810A-P17	U-RING	1
P18	PRT5810A-P18	SMALL PISTON	1
P19	PRT5810A-P19	CIRCLIP	1
P20	PRT5810A-P20	BIG PISTON	1
P21	PRT5810A-P21	STEEL BALL	1
P22	PRT5810A-P22	STEEL BALL SEAT	1
P23	PRT5810A-P23	SPRING	1
P24	PRT5810A-P24	SCREW	1

ITEM#	ORDERING PART#	PART DESCRIPTION	QTY
P25	PRT5810A-P25	O-RING	2
P26	PRT5810A-P26	SCREW	2
P27	PRT5810A-P27	CAP	1
P28	PRT5810A-P28	O-RING	1
P29	PRT5810A-P29	RELEASE VALVE	1
P30	PRT5810A-P30	HOSE	1
P31	PRT5810A-P31	COUPLER	1
P32	PRT5810A-P32	DUST CAP	1
P33	PRT5810A-P33	CONNECTOR	1
P34	PRT5810A-P34	NUT	1
P35	PRT5810A-P35	CONNECTOR	1
P36	PRT5810A-P36	O-RING	1
P37	PRT5810A-P37	SPRING	1
P38	PRT5810A-P38	PRESSURE GAUGE	1
P39	PRT5810A-P39	CIRCLIP	2
P40	PRT5810A-P40	PIN	1
P41	PRT5810A-P41	PIN	1
P42	PRT5810A-P42	HANDLE	1
P43	PRT5810A-P43	HANDLE GRIP	1
P44	PRT5810A-P44	SCREW	1
P45	PRT5810A-P45	BASE	1
N/S	PRT5810A-SK	SEAL KIT	1

* - Seal Kit Includes: P2, P4, P13, P15, P16, P17, P25, P28, P36, R06, R07, SP07, SP08, SP12/R16, & SP13/R17

** - Piston and Piston Seat includes: P18, P19, P20

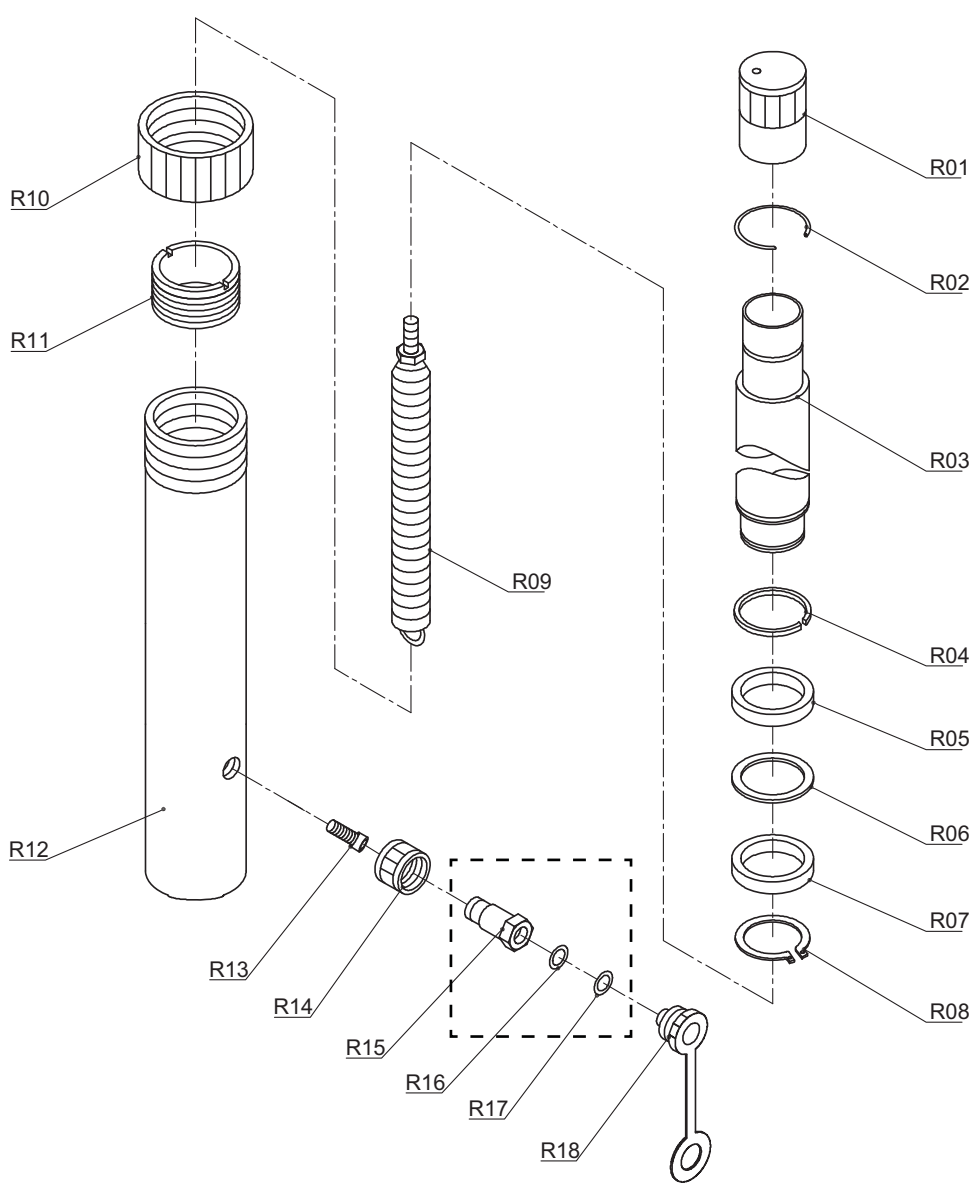

ITEM#	ORDERING PART#	PART DESCRIPTION	QTY
R01	PRT5810A-R01	COVER	1
R02	PRT5810A-R02	RETAINING RING	1
R03	PRT5810A-R03	PISTON ROD	1
R04	PRT5810A-R04	RETAINING RING	1
R05	PRT5810A-R05	WASHER	1
R06	PRT5810A-R06	SEAL RING	1
R07	PRT5810A-R07	U-RING	1
R08	PRT5810A-R08	SNAP RING	1
R09	PRT5810A-R09	SPRING	1
R10	PRT5810A-R10	COVER	1
R11	PRT5810A-R11	LIMIT RING	1
R12	PRT5810A-R12	CYLINDER	1
R13	PRT5810A-R13	SCREW	1
R14	PRT5810A-R14	NUT	1
R15	PRT5800A-SP11-1	COUPLER	1
R16	PRT5800A-SP11-1	O-RING	1
R17	PRT5800A-SP11-1	SEAL RING	1
R18	PRT5810A-R18	DUST CAP	1

* PRT5800A-SP11-1 connector includes R15, R16 & R17

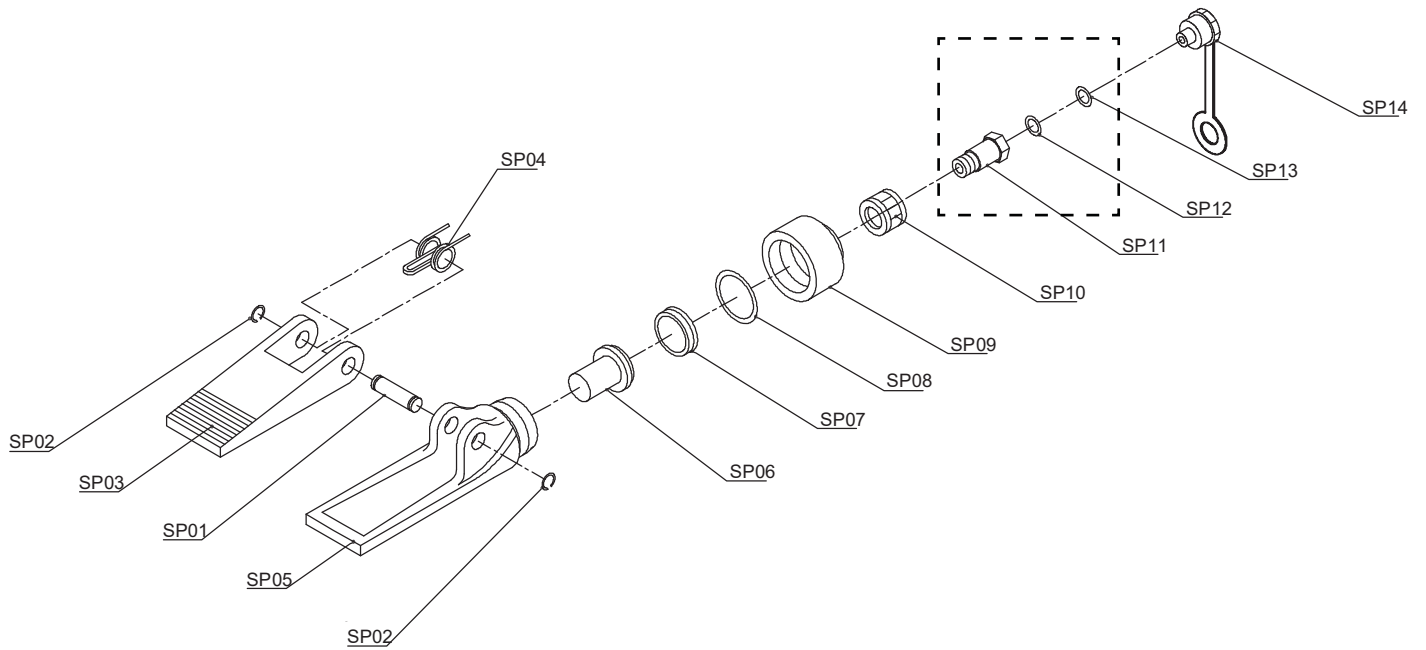

ITEM#	ORDERING PART#	PART DESCRIPTION	QTY
SP1	PRT5800A-SP1	PIN	1
SP2	PRT5800A-SP2	RETAINING RING	1
SP3	PRT5800A-SP3	MOVABLE JAW	1
SP4	PRT5800A-SP4	SPRING	1
SP5	PRT5800A-SP5	FIXED JAW	1
SP6	PRT5800A-SP6	PISTON	1
SP7	PRT5800A-SP7	SEAL RING	1
SP8	PRT5800A-SP8	O-RING	1
SP9	PRT5800A-SP9	END CAP	1
SP10	PRT5800A-SP10	NUT	1
SP11	PRT5800A-SP11-1	CONNECTOR	1
SP12	PRT5800A-SP11-1	O-RING	1
SP13	PRT5800A-SP11-1	SEAL RING	1
SP14	PRT5800A-SP14	DUST CAP	1

* PRT5800A-SP11-1 connector includes SP11, SP12 & SP13



ATD[®]

WARRANTY

1 YEAR LIMITED WARRANTY

THIS WARRANTY AND CONFIRMED RECEIPT(S) SHOULD BE RETAINED BY THE CUSTOMER AT ALL TIMES

PURCHASED FROM: _____

DATE PURCHASED: _____

INVOICE/RECEIPT NUMBER: _____

Your ATD-5800A or ATD-5810A is warranted for a period of 12 months from the original purchase date.

For a period of one (1) year from your purchase date, ATD Tools, Inc. will repair or replace (at its option) without charge, your ATD product if it was purchased new and the product has failed due to a defect in material or workmanship which you experienced during normal use of the product. This limited warranty is your exclusive remedy.

To access the benefits of this warranty, contact your supplier, or point of sale directly. You may be advised to return the product under warranty, freight prepaid, to your supplier for warranty determination.

If this ATD product is altered, abused, misused, modified, or undergoes service by an unauthorized technician, your warranty will be void. We are not responsible for damage to ornamental designs you place on this ATD product and such ornamentation should not cover any warnings or instructions or they may void the warranty. This warranty does not cover scratches, superficial dents, and other abrasions to the paint finish that occur under normal use. It also does not cover normal wear items such as but not limited to brushes, batteries, drill bits, drill chucks, pads or blades.

Subject to the law in your state:

- (1) Your sole and exclusive remedy is repair or replacement of the defective product as described above.
- (2) ATD is not liable for any incidental damages, including but not limited to, lost profits and unforeseeable consequences.
- (3) The repair and replacement of this product under the express limited warranty described above is your exclusive remedy and is provided in lieu of all other warranties, express or implied. All other warranties, including implied warranties and warranties of merchantability or fitness for a particular purpose are disclaimed and, if disclaimer is prohibited, these warranties are limited to one year from your date of purchase of this product.

Some states' laws do not allow limited durations on certain implied warranties and some states' laws do not allow limitations on incidental or consequential damages. You should consult the law in your state to determine how your rights may vary.

[Affix receipt or invoice here for safe keeping]