



ATD-5585 Premium Automotive DMM Owner's Manual



Features:

Highest quality auto-ranging DMM designed for automotive trouble shooting. Min/Max Mode records transient voltages as fast as 1 millisecond. Milliseconds pulse width measures fuel injector on-time. Also measures temperature via temp probe in both °F and °C and a desirable 20 Amp test range. Unit has dual fuse protection, modern design and protective holster built into the housing. Instruction manual and molded storage case included.

- (48) Test ranges
- (18) Test functions
- rpm for DIS and standard ignitions
- Data hold, auto power off and trigger adjust
- Test leads
- Large LCD display with white LED backlighting
- (40) segment analog bar graph
- Min/Max Mode records variation in all functions
- K-type temp probe
- Inductive rpm clamp

ATD-5585

OWNER'S MANUAL

Contents

| | |
|---|----|
| Safety..... | 3 |
| Meter Basics..... | 4 |
| Digital LCD Display..... | 5 |
| Push-button Functions..... | 6 |
| Mode Button..... | 6 |
| Manual range & Stroke 4/2,Hz,%,ms,CYL Button..... | 6 |
| Data Hold /Backlight Button..... | 7 |
| Peak Hold..... | 7 |
| Meter Functions Voltage (V)..... | 8 |
| Resistance (Ω)..... | 9 |
| Diode Check(\rightarrow)..... | 10 |
| Capacitance (CAP)..... | 11 |
| Audible Continuity (\cdot)..... | 12 |
| AC or DC Current (A)..... | 13 |
| Temperature ($^{\circ}$ C/ $^{\circ}$ F)..... | 14 |
| Frequency (Hz)..... | 15 |
| Dwell..... | 16 |
| Duty Cycle (%)..... | 17 |
| Ms – PULSE..... | 18 |
| RPM..... | 19 |
| General Specifications..... | 20 |
| Electrical Specifications..... | 20 |
| Replacing the Battery..... | 24 |
| Battery Installation..... | 24 |
| Replacing the Fuses..... | 24 |
| Trouble Shooting..... | 25 |
| Warranty Information..... | 26 |

SAFETY



- Engines produce carbon monoxide which is odorless, causes slower reaction time, and can lead to serious injury. When the engine is operating, keep service areas WELL VENTILATED or attach the vehicle exhaust system to the shop exhaust removal system.
- Set the parking brake and block the wheels before testing or repairing the vehicle. It is especially important to block the wheels on front-wheel drive vehicles; the parking brake does not hold the drive wheels.
- Wear safety glasses when testing or repairing vehicles.
- Exceeding the limits of this meter is dangerous. It will expose you to serious or possibly fatal injury. Carefully read and understand the cautions and the specification limits of this meter.
- Voltage between any terminal and ground must not exceed 600V AC or 600V DC.
- Use caution when measuring voltage above 25V AC or 25V DC.
- Circuit tested must be protected by a 20A fuse or circuit breaker.
- Do not use the meter if it has been damaged.
- Do not use the test leads if the insulation is damaged or if metal is exposed.
- Avoid electrical shock: Do not touch the test leads, tips or the circuit being tested.
- Do not attempt a voltage measurement with the test leads in the 20A or the mA terminal.
- When testing for the presence of voltage or current, make sure the meter is functioning correctly. Take a reading of a known voltage or current before accepting a zero reading.
- Choose the proper range and function for the measurement. Do not try voltage or current measurements that may exceed the ratings marked on the function/range switch or terminal.
- When measuring current, connect the meter in series with the load.
- Never connect more than one set of test leads to the meter.
- Disconnect the live test lead before disconnecting the common test lead.
- The mA and the 20A terminals are protected by fuses. To avoid possible injury or damage, use only in circuits limited to 400mA or 20A for 30 seconds.

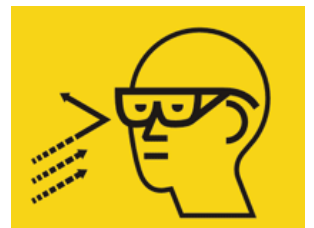

IMPORTANT

- To maintain accuracy of the meter, replace the discharged battery immediately when the battery symbol appears on the meter display.
- Avoid measuring error from outside interference: keep the meter away from spark plug or coil wires.
- Avoid damaging the meter when testing voltage: disconnect the test leads from the test points before changing functions.
- Do not exceed the limits shown in the table below:

| FUNCTION | Terminal | Input limit |
|---|----------|-----------------|
| DC/AC Volts, Ohm/Continuity Diode,CAP,IR TEMP Adaptor, Type-K TEMP, Hz, %Duty, Ms Dwell, RPM | V-Ω-RPM | 600 Volts AC/DC |
| AC/DC μA mA | μA mA | 400mA AC/DC |
| AC/DC 20A | 20A | *20A AC/DC |

- 20 Amp measurement for 30 seconds maximum.
- Ohms can not be measured if voltage is present, ohms can be measured only in a non-powered circuit. However, the meter is protected to 600 volts.

METER BASICS

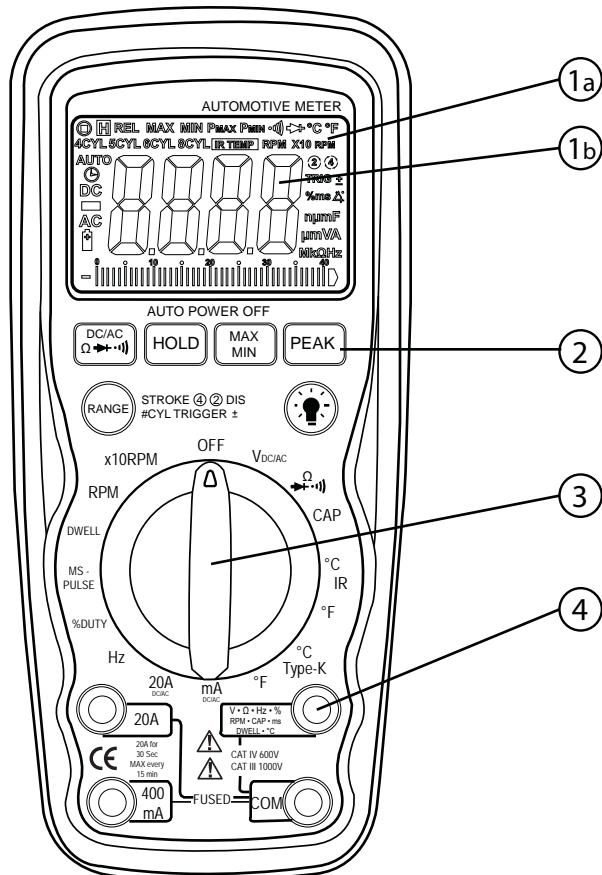

1. Digital LCD display:

- 1a. Symbols to identify function
- 1b. Four character digital display

The digital display is best for stable inputs.
The bar graph display is best for rapidly changing inputs.

2. Function Buttons

Press the button to select a function.
A symbol will appear to confirm your choice.

3. Rotary Selector Switch:

Turn this switch to select a function or turn the meter OFF.

4. Volts Terminal

The red test lead is used to measure; Amps, Volts, Ohms, TEMP, Hz, RPM, Cap, mS and Dwell.

The black test lead is used in the common (COM) terminal for all tests.

LCD DISPLAY SYMBOLS AND ANNUNCIATORS

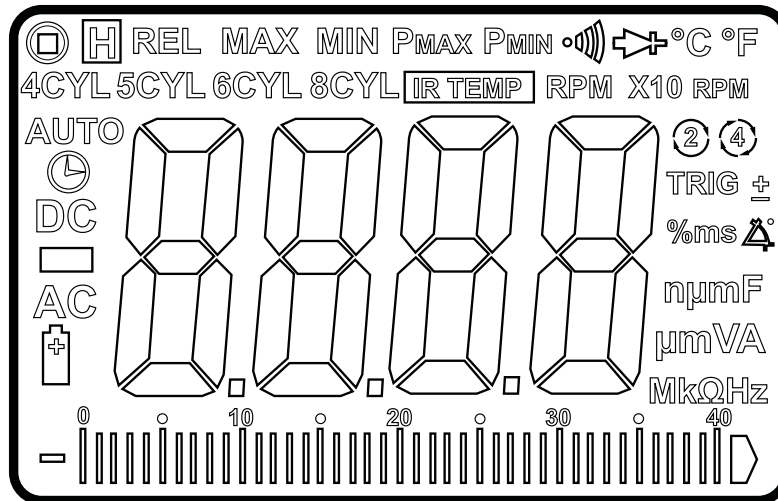

| | | |
|-----------|---|---|
| 8.8.8.8 | - | LCD digits |
| • | - | Continuity |
| BAT | - | Low Battery |
| ➔ | - | Diode |
| DATA HOLD | - | Data Hold |
| AUTO | - | AutoRanging |
| AC | - | Alternating Current or Voltage |
| DC | - | Direct Current or Voltage |
| n | - | Nano (10 ⁻⁹) (capacitance) |
| µ | - | Micro (10 ⁻⁶) (amps, capacitance) |
| m | - | Milli (10 ⁻³) (volts, amps) |
| A | - | Amps |
| k | - | Kilo (10 ³) (ohms) |
| F | - | Farads (capacitance) |
| M | - | Mega (10 ⁶) (ohms) |
| Ω | - | Ohms |
| Hz | - | Hertz (frequency) |
| V | - | Volts |
| % | - | Percent (duty ratio) |
| °F | - | Degrees Fahrenheit |
| °C | - | Degrees Centigrade |
| IR TEMP | - | Infrared Temperature |

PUSH BUTTON FUNCTIONS

Mode Button

Press the mode pushbutton to select the following functions; DC/AC Voltage, DC/AC Current Resistance, Diode, Continuity & Capacitance

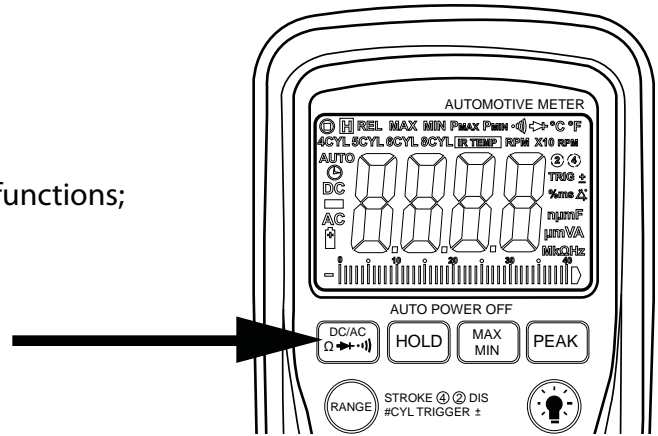

Manual Range & Stroke 4/2(DIS), Hz, %, ms +/-, CYL Button

Press to this button to select; STROKE 4, 2DIS, Hz, %, ms+, CYL range & V/A/ Resistance manual Range

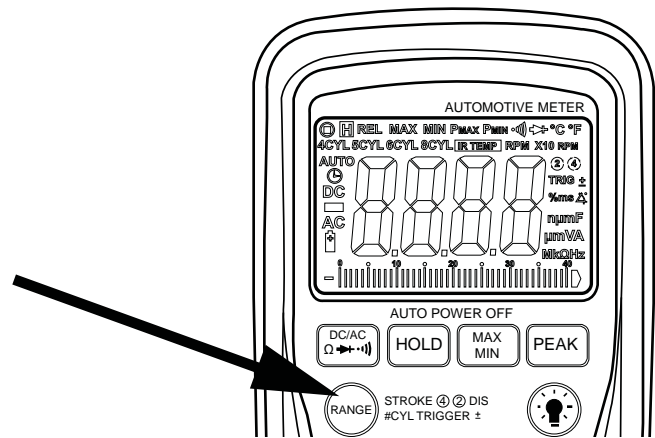

Manual Ranging

The meter turns on in the autoranging mode. Press the Range button to go to manual ranging. The display icon "○" will appear. Each press of the range button will step to the next range as indicated by the units and decimal point location. Press and hold the Range button for two seconds to return to autoranging.

Data Hold

The Data Hold function allows the meter to "freeze" a measurement for later reference.

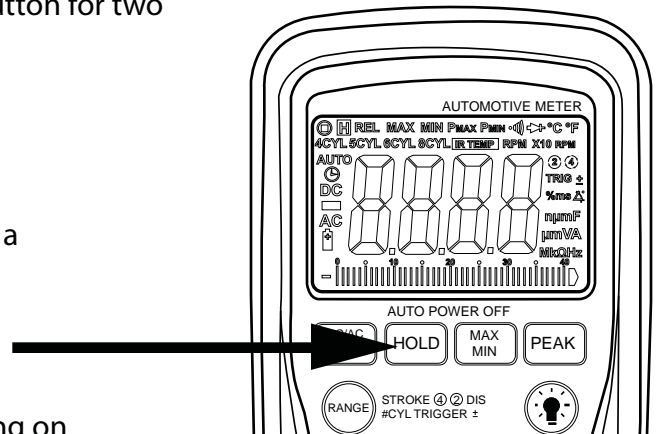

1. Press the DATA HOLD button to "freeze" the reading on the indicator. The indication of "HOLD" will appear in the display.
2. Press the DATA HOLD button again to return to normal operation.

Peak Hold

The Peak Hold function captures the peak AC or DC voltage or current. The meter can capture negative or positive peaks as fast as 1 millisecond in duration.

1. Set the function switch to the Amps or Volts.
2. Press and Hold the PEAK button until "CAL" appears in the display. This procedure will zero the range selected & the meter will go into manual ranging mode.
3. Press the PEAK button, Pmax will display.
4. The display will update each time a higher positive peak occurs.
5. Press the PEAK button again, Pmin will display. The display will now update and indicate the lowest negative peak.
6. To return to normal operation, press and hold the PEAK button until the Pmin or Pmax indicator switches off.

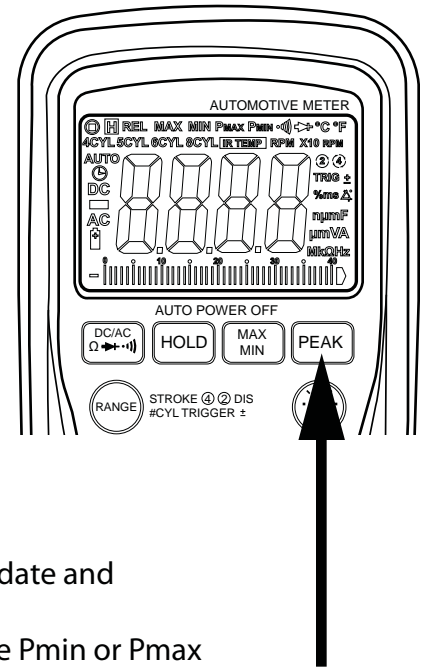

Note: If the Function switch position is changed after a calibration the Peak Hold calibration must be repeated for the new function selected.

MAX/MIN

1. Press the MAX/MIN key to activate the MAX/MIN recording mode. The display icon "MAX or MIN" will appear. The meter will go into manual ranging mode & display and hold the maximum or minimum reading and will update only when a new "max or min" occurs.
 2. Press the MAX/MIN key and a blinking "MAX MIN" will appear. The meter will display the present reading, but will continue to update and store the max and min readings.
- To exit MAX/MIN mode press and hold the MAX/MIN key for 2 seconds.

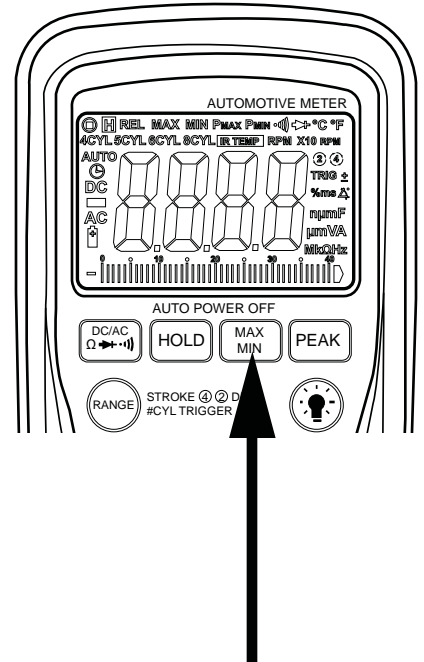

Backlight Button

1. Press the BACKLIGHT button to turn the backlighting ON.
2. Press the BACKLIGHT button again to turn the backlighting OFF.

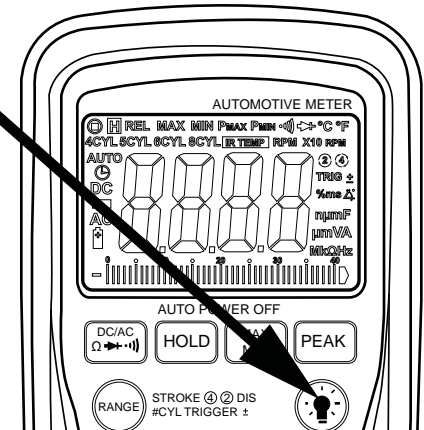

Meter Functions - Voltage (V)

- Select the Volts "V" range with the rotary switch.
- The meter will automatically select the best voltage (V) range.
- Select DCV or ACV with the MODE button

Insert:

- Black lead in COM terminal.
- Red lead in V-Ω-RPM terminal.

Touch the Black probe to ground or to the negative (-) circuit.
Touch the Red probe to the circuit coming from the power source.

IMPORTANT: Voltage must be measured in parallel
(Red probe measuring circuit from power source).

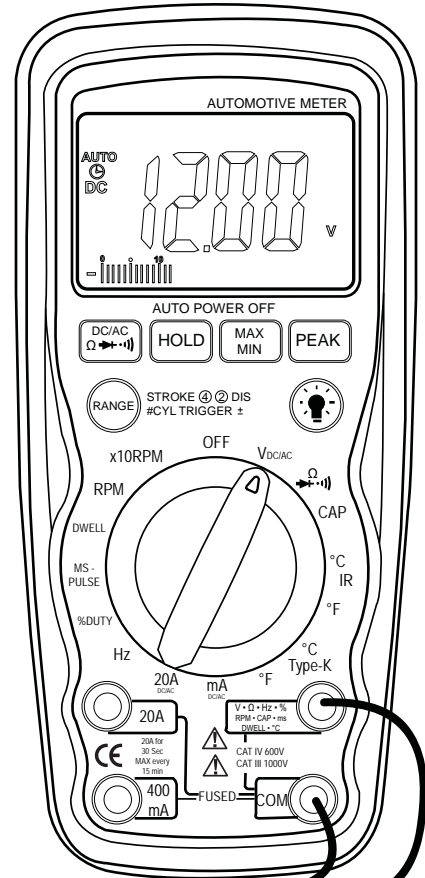

When measuring voltage, be sure the red test lead is in the terminal marked "V". If the test lead is in an Amp (A) or Milliampere (mA) terminal, you may be injured or the meter damaged.

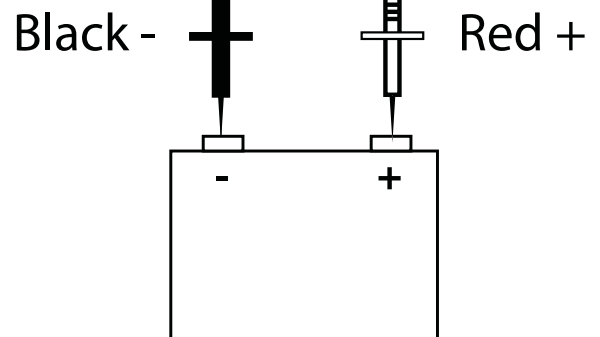

Meter Functions - Resistance (Ω)

IMPORTANT: If you are testing an application that has capacitors in the circuit, be sure to turn the power OFF on the test circuit and discharge all capacitors. Accurate measurement is not possible if external or residual voltage is present.

- Select the resistance (Ω) range with the rotary switch.
- Select the resistance (Ω) function with the MODE button. Please note the unit defaults to resistance

Insert:

- Black lead in COM terminal.
- Red lead in V- Ω -RPM terminal.
- Touch the test lead probes across the resistor to be tested.

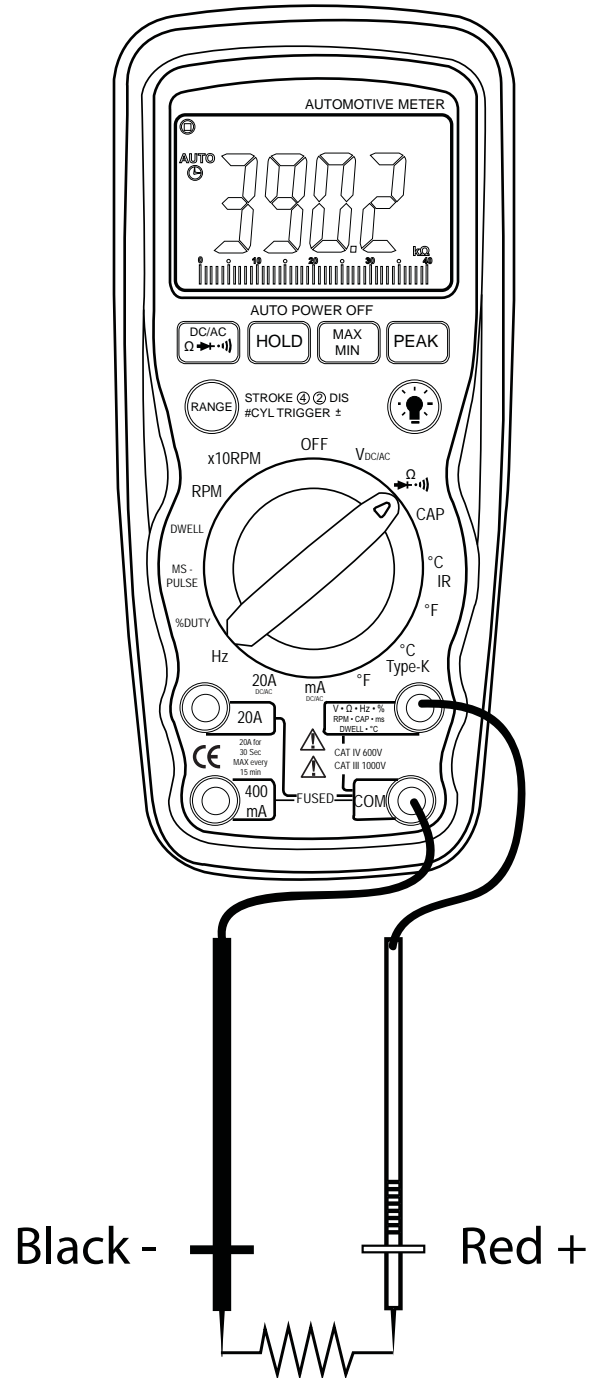

Meter Functions – Diode Check (▶)

IMPORTANT: Turn the power OFF to the test circuit

- Select the Diode Check (▶) setting with the rotary switch and MODE button.

Insert:

- Black lead in COM terminal.
- Red lead in V-Ω-RPM terminal.

Touch the Black test probe to the negative (-) side of the diode.

Touch the Red test probe to the positive (+) side of the diode.

Reverse the probes : Black to the positive (+) side and Red to the negative (-) side.

Note:

A good diode will read low in one direction and high in the other direction when the probes are reversed (or vice versa). A defective diode will have the same reading in both directions or read between 1.0 to 3.0V. in both directions

| Diode | (-) to (+) | Reverse Probes (+) to (-) |
|-------|-------------|---------------------------|
| Good | .4 to .9V | OL |
| | OL | .4 to .9V |
| Bad | OL | 1.0 to 3.0V |
| | 1.0 to 3.0V | OL |
| | .4 to .9V | .4 to .9V |
| | OL | OL |
| | .000V | .000V |

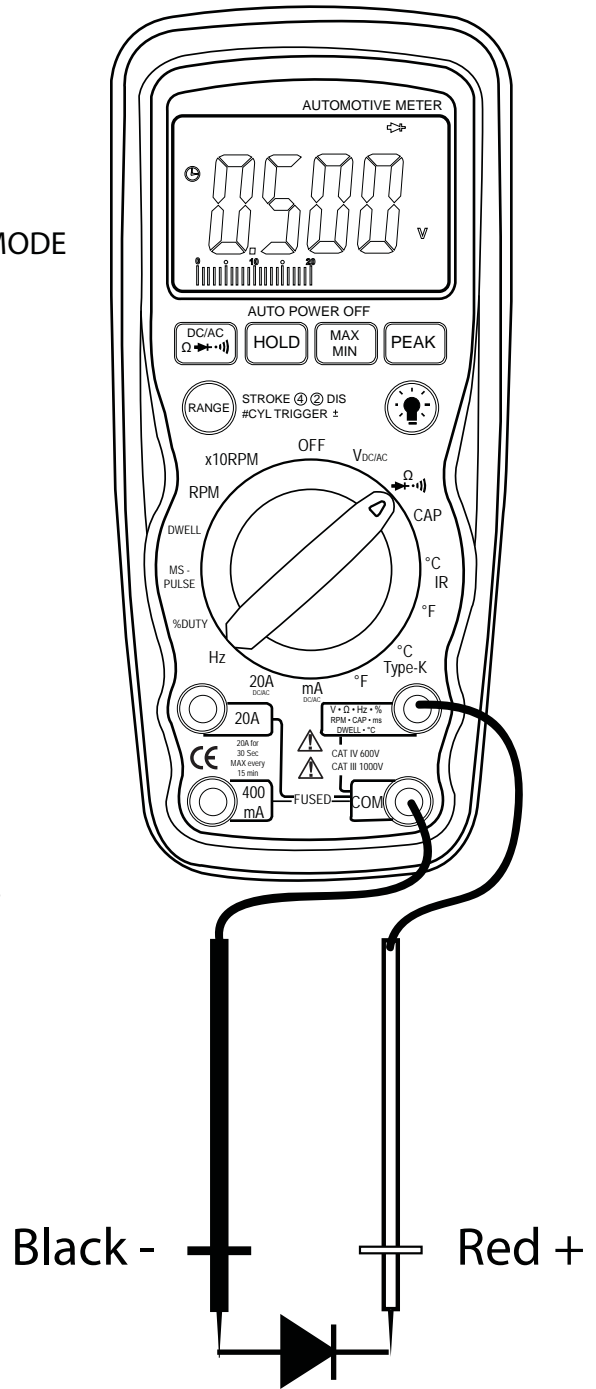

Meter Functions – Capacitance (CAP)

IMPORTANT: Turn the power OFF to the test circuit

- Select the Capacitance (CAP) setting with the rotary switch and MODE button.

Insert:

- Black lead in COM terminal.
- Red lead in V- Ω -RPM terminal.

CAUTION: When checking in-circuit capacitance, be sure that the circuit has all power removed and all capacitors are fully discharged.

Touch the test lead probes across the capacitance circuit to be tested. Read the measured value from the LCD display.

Note:

1. The bar graph is disabled in capacitance measurement mode. However, since the measurement time of 4mF and 40mF modes is quite long (3.75s and 7.5s respectively, to be precise), the bar graph is instead used to display the time required to accomplish the measurement.
2. In order to obtain an accurate reading, a capacitor must be discharged before measurement begins. The meter has a built-in discharge mode to automatically discharges the capacitor. In discharge mode, the LCD displays "DISC"
3. Discharging through the chip is quite slow. We recommend the user to discharge the capacitor with some other apparatus.

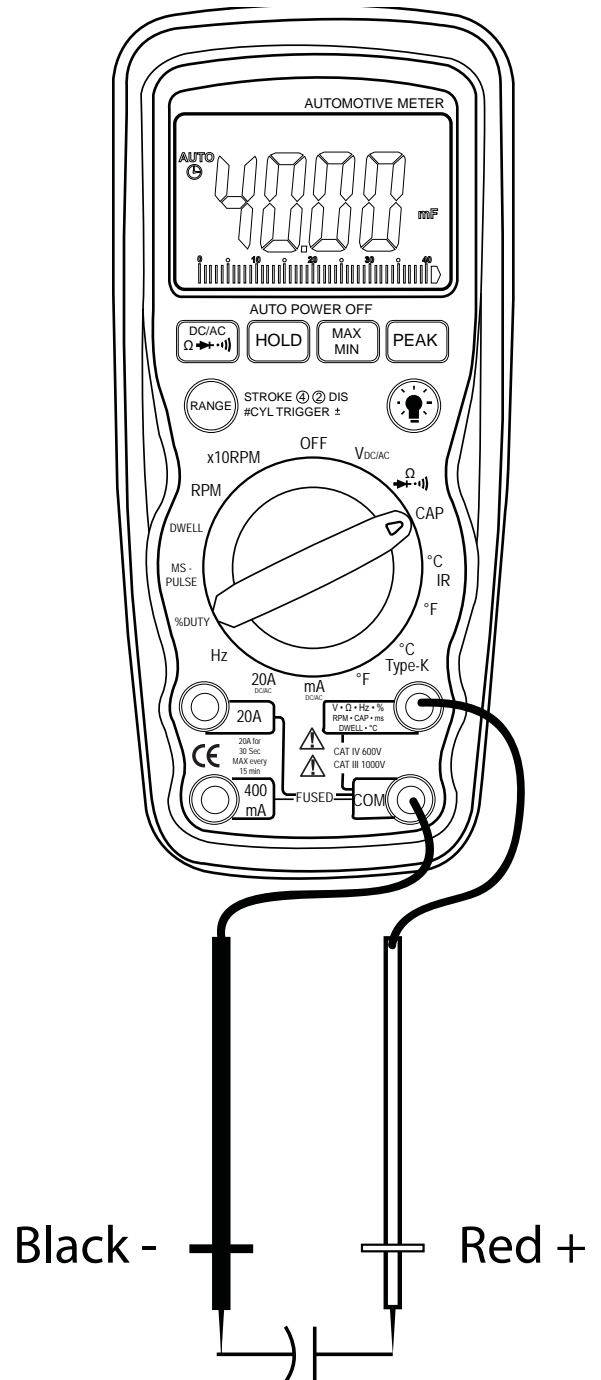

Meter Functions – Audible Continuity (•)))

IMPORTANT: Turn the power OFF to the test circuit

- Select the Audible Continuity (•))) setting with the rotary switch.

Insert:

- Black lead in COM terminal.
- Red lead in V- Ω -RPM terminal.

Touch one test probe to each end of the circuit to be tested.

If the circuit is complete, the meter will beep continuously.

If the circuit is open, there will be no beep and the display will show "OL" (over limit)

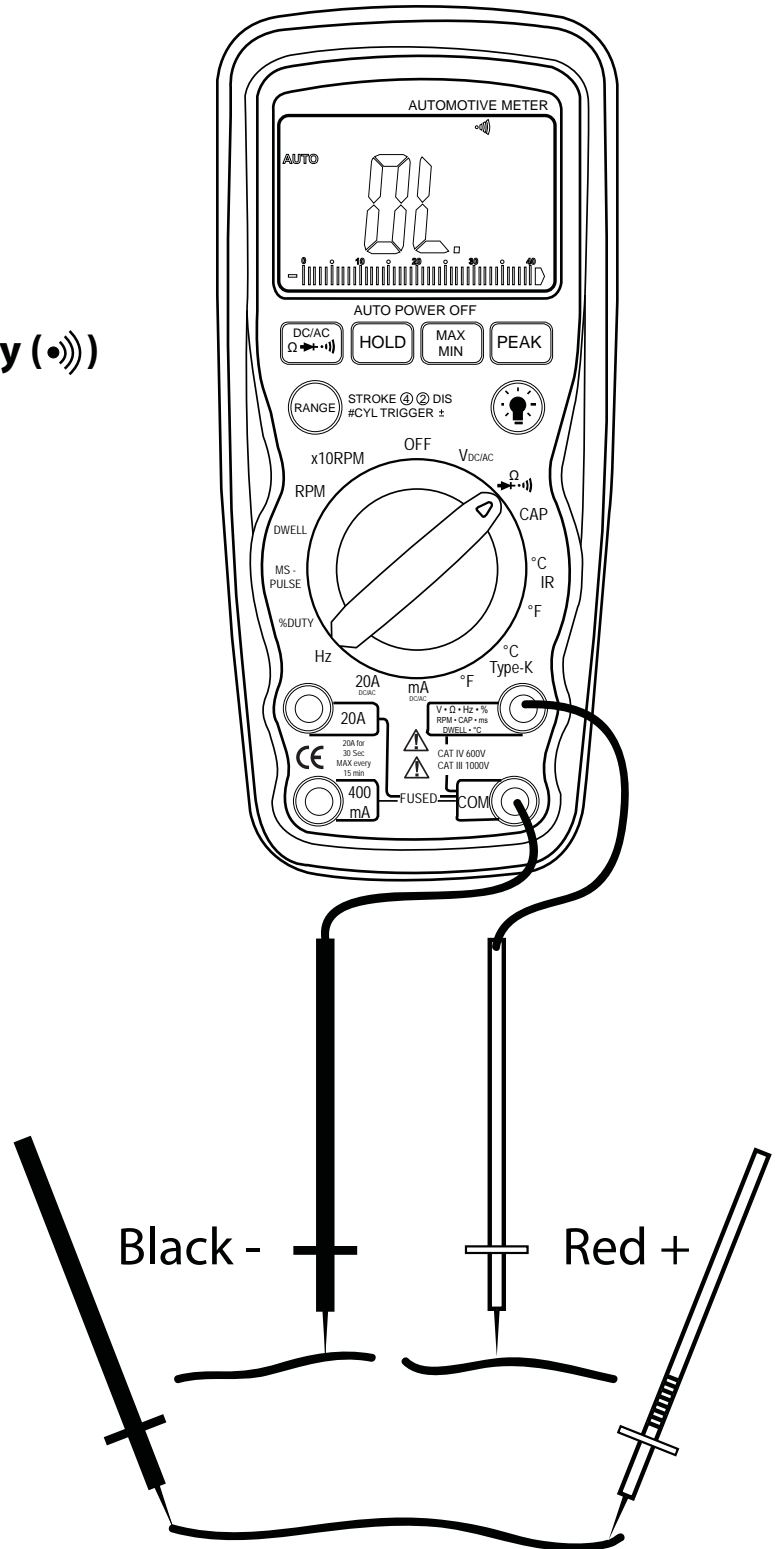

Circuit complete - meter will beep continuously

Meter Functions – AC or DC Current (A)

IMPORTANT: All current measured flows through the meter. It is important that you **DO NOT**:

- **DO NOT** measure current greater than 600 Volts AC or DC, with respect to ground.
- **DO NOT** exceed 30 seconds when measuring continuous current between 1A-20A. Allow five minutes for cool down before continuing.
- **DO** Select the “20A” or “mA” range with the rotary switch.
- **DO** press the Mode button to select AC or DC.

Insert:

- Black lead in COM terminal.
- Red lead in the 20A or mA terminal (select 20A if you are unsure of the current draw).

IMPORTANT:

Turn OFF all power to the circuit or disconnect the circuit from the power source.

Connect:

- The Red probe to the side of the circuit closest to the power source.
- The Black probe to the side of the circuit to ground.
- Turn the power ON and test.

Note:

Current must always be measured with the meter test probes connected in series, as described.

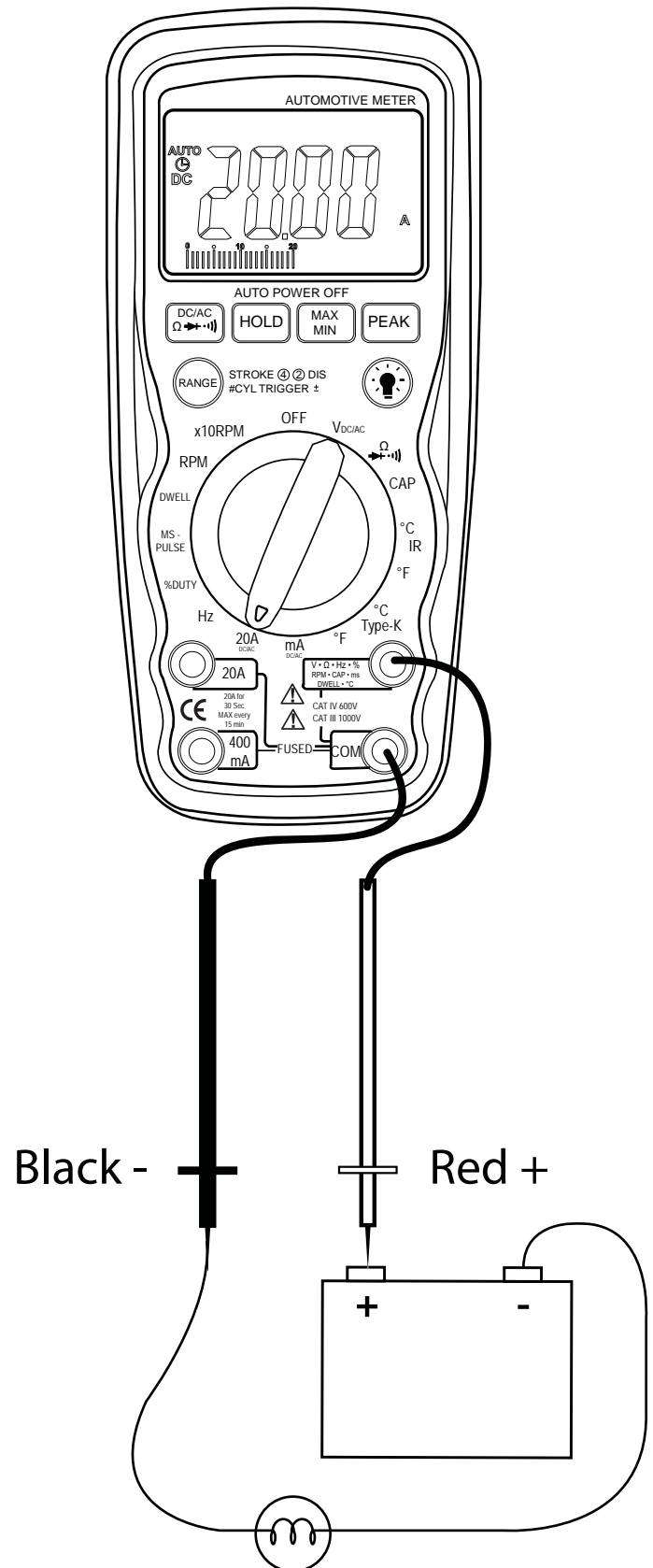

Meter Functions –Temperature (°C/°F)

IMPORTANT: To avoid heat damage to the meter, keep it away from sources of very high temperature. The life of the Temperature Probe is also reduced when subjected to very high temperatures. Probe operating range is -58° to 482°F .

- Select the Temperature “°C or °F” function with the rotary switch.
- Insert the temperature probe connector into the K-type thermocouple adapter. Insert the adapter into the front of the meter as shown.
- Touch the end of the temperature sensor to the area or surface of the object to be measured.

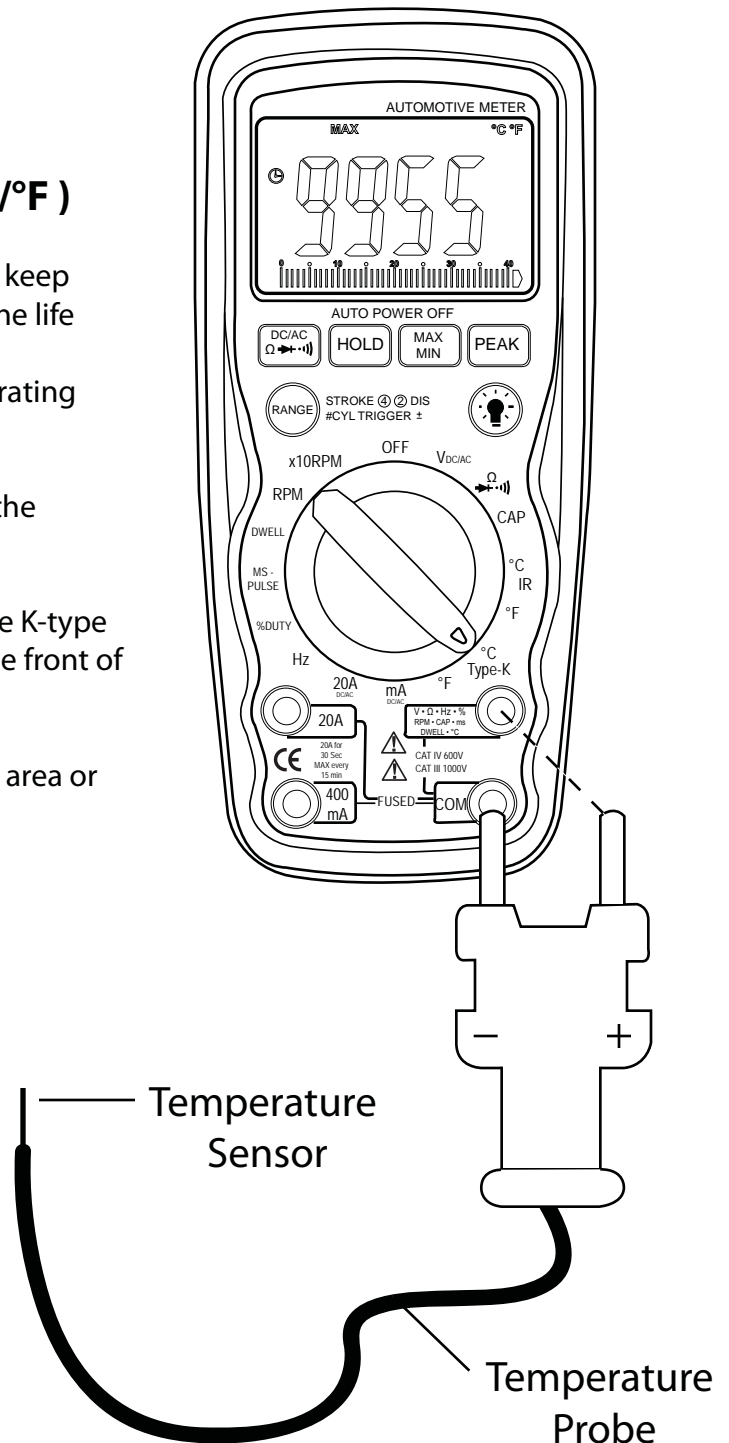

Meter Functions – Frequency (Hz)

- Select the “Hz” (Frequency) setting with the rotary switch.

Insert:

- Black lead in COM terminal
- Red lead in V-Ω-RPM terminal.

Connect the Black test probe to ground.

Connect the Red test probe to the “signal out” wire of the sensor to be tested.

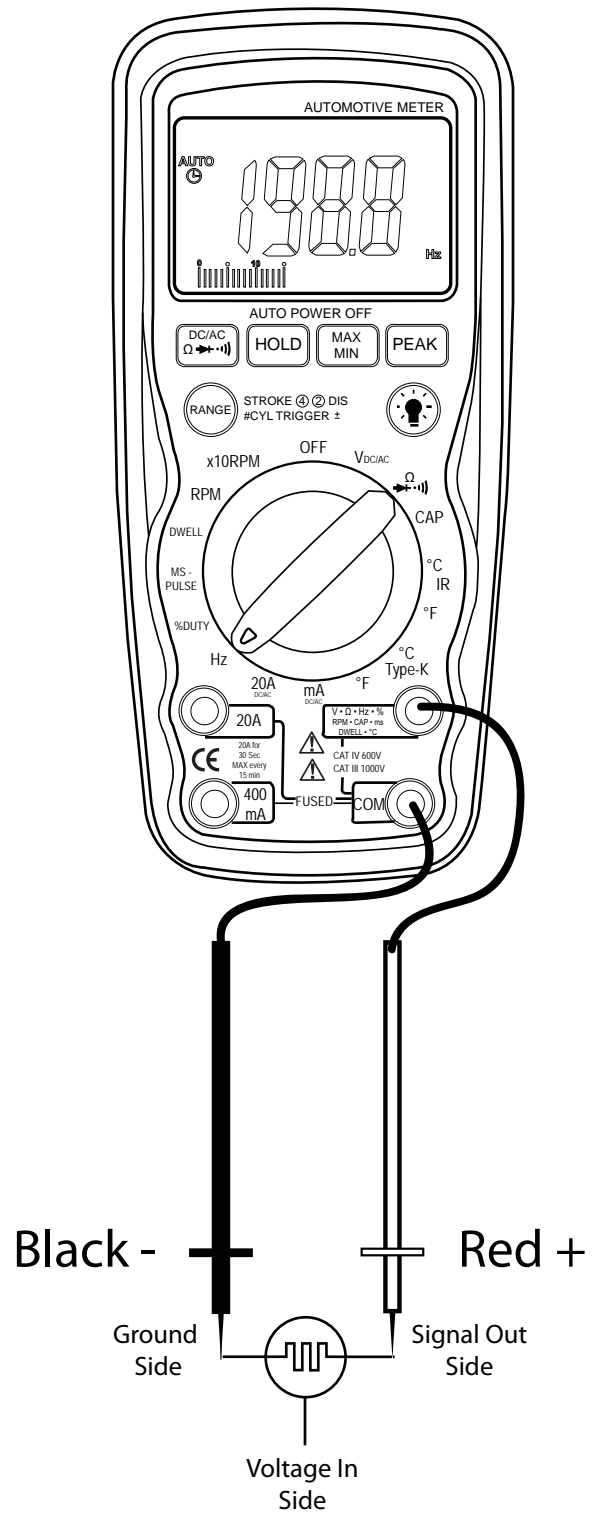

Meter Functions – Dwell

- Select the proper Dwell range with the rotary switch.

Insert:

- Black lead in COM terminal
- Red lead in V-Ω-RPM terminal.

Connect the Black test probe to ground.

Connect the Red test probe to the wire that connects to the breaker points (see illustration).

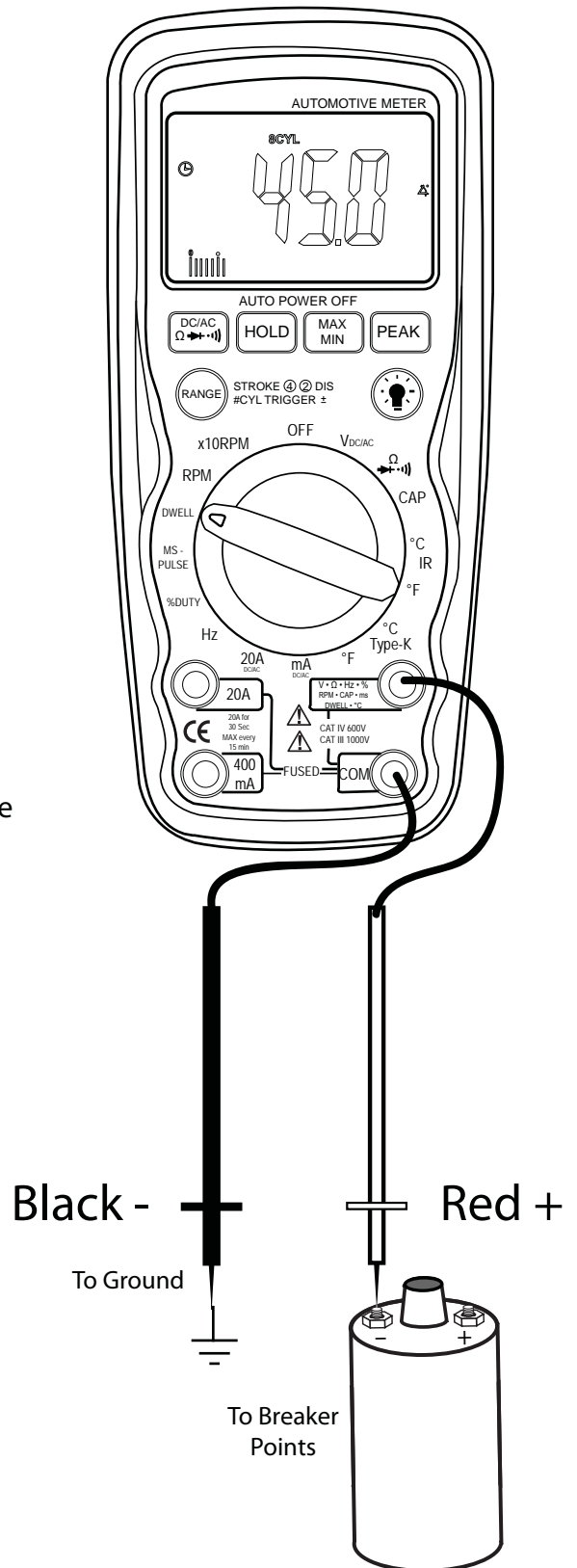

Meter Functions – Duty Cycle (%)

- Select the % Duty Cycle range with the rotary switch.

Insert:

- Black lead in COM terminal
- Red lead in V-Ω-RPM terminal.

Connect the Black test probe to ground.

Connect the Red test probe to the signal wire circuit (see illustration).

The illustration for a mixture control solenoid is shown with the metering rod in the closed position. The meter will display the percentage of time the plunger is in the closed position (low duty cycle) during one duty cycle.

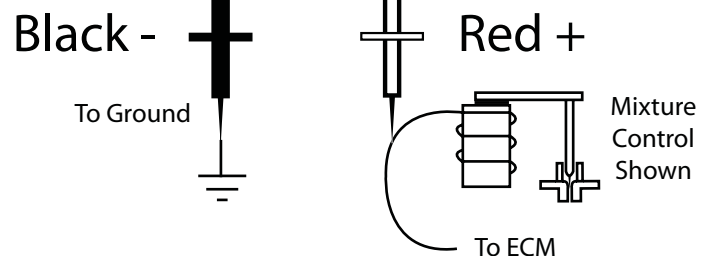
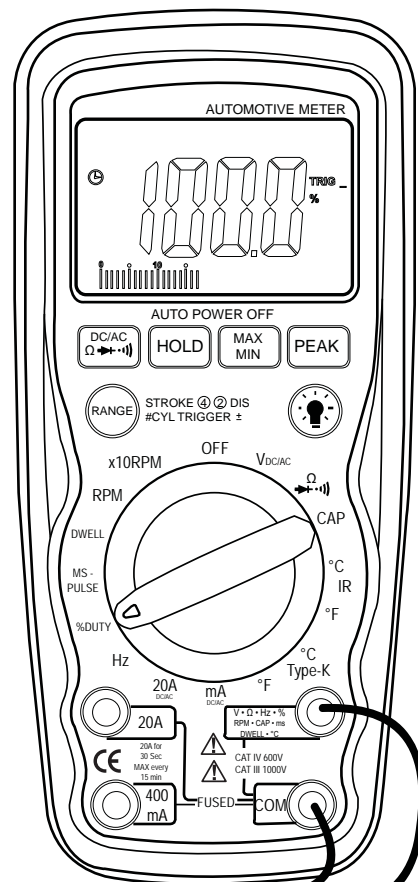

Meter Functions- ms-PULSE (Pulse Width) & ms- PERIOD (Period)

Pulse Width is the length of time an actuator is energized. For example, fuel injectors are activated by an electronic pulse from the Engine Control Module (ECM).

This pulse generates a magnetic field that pulls the injectors nozzle valve open.

The pulse ends and the injector nozzle is closed.

This open to close time is the Pulse Width and is measured in milliseconds(ms).

The most common automotive application for measuring pulse width is on fuel injectors.

You can also measure the pulse width of the fuel mixture control solenoid and the idle air control motor.

Measuring Pulse Width on Port Fuel injectors is described on the following page.

To measure pulse width (mS):

- Select the “mS-Pulse” function with the rotary switch .
- Press the \pm TRIG button for 2 seconds until the negative (-) trigger slope is displayed on the upper left side of the display.

NOTE: The applied time for most fuel injectors is displayed on the negative (-) slope.

Insert:

- Black lead in COM jack.
- Red lead in V- Ω -RPM jack.

Connect:

Jumper wires between the fuel injector and the harness connector.

Black test probe to a good ground at the fuel injector or the negative (-) vehicle battery post.

Red test probe to the fuel injector solenoid driver input on the jumper cable.

Start the engine. A pulse width in milliseconds should be read.

Note: Initially, the unit will read “OL”, then readings will descend and stabilize to the actual pulse width. If “OL” remains, re-check your connections.

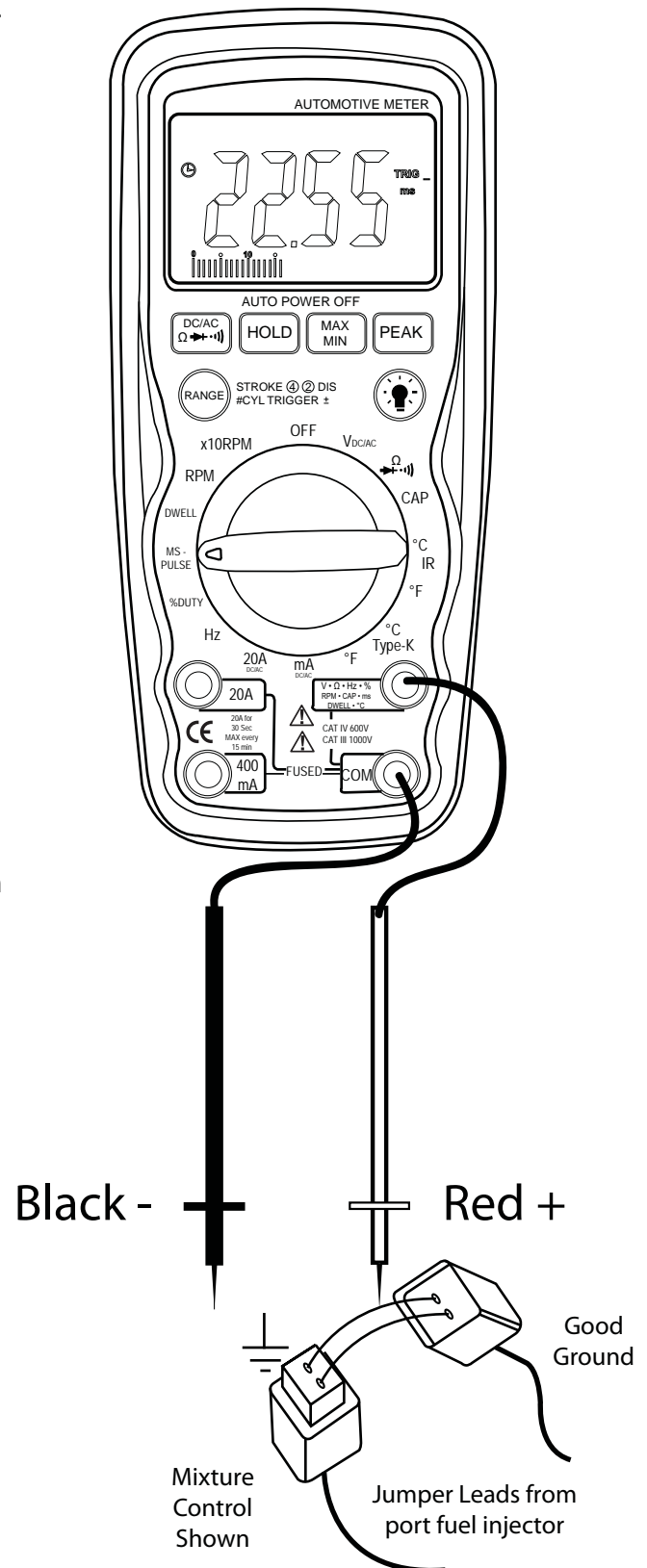

Meter Functions – RPM / x10 RPM

- Select the RPM range with the rotary switch.
OR
- Select the x 10 RPM range with the rotary switch (1,000 to 12,000 RPM). Multiply the displayed reading times by ten to get actual RPM.

Press STROKE ④ ② / DIS button to select through RPM ④ for 4-stroke, RPM ② for 2-stroke and DIS ignitions

- Insert the inductive pickup connecting terminal into the meter.
- Ground lead in COM terminal.
- Output lead in V -Ω- RPM terminal.
- Connect the inductive pickup to a spark plug wire. If no reading is received, unhook the clamp, turn it over and connect again.

Note:

- *Position the inductive pick-up as far away from the distributor and the exhaust manifold as possible.*
- *Position the inductive pick-up to within six inches of the spark plug or move it to another plug wire if no reading or an erratic reading is received.*

RPM 4 : For RPM of 4-stroke engines which have 1 ignition on every 4 engine strokes

RPM 2 : For RPM of DIS (Distributorless Ignition System) & 2-stroke engines which have 1 ignition on every 2 engine strokes

PLEASE NOTE- THE RPM PICK-UP HAS AN ADJUSTABLE SENSITIVITY SWITCH THAT CAN ALSO BE USED TO CORRECT AN UNSTABLE READING.

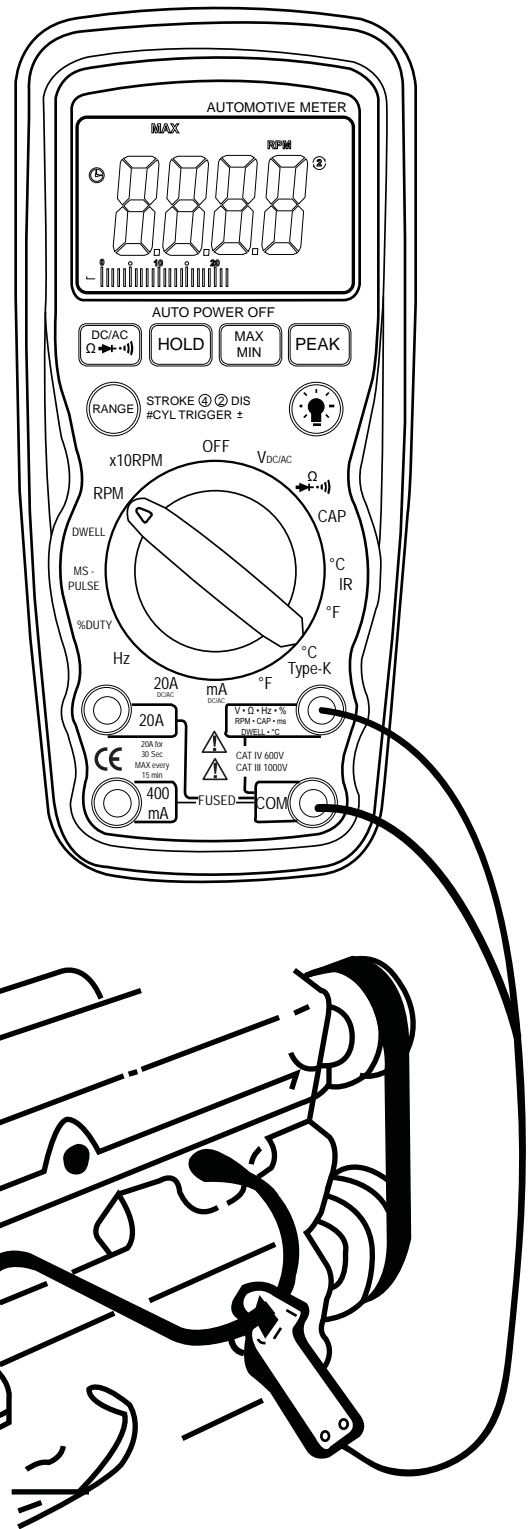

General Specifications

The instrument complies with IEC 1010-1 EN61010-1.

Insulation: Class2, Double insulation.

Overvoltage category: CATIII1000V/CATIV600V.

Display: 4000 counts LCD display with function indication.

Polarity: Automatic, (-) negative polarity indication.

Overrange: "OL" mark indication.

Low battery indication: The "BAT" is displayed when the battery voltage drops below the operating level.

Measurement rate: 2 times per second, nominal.

Auto power off: Meter automatically shuts down after approx. 30 minutes of inactivity.

Operating environment: 0° C to 50° C (32° F to 122° F) at < 70 % relative humidity.

Storage temperature: -20° C to 60° C (-4° F to 140° F) at < 80 % relative humidity.

For inside use, max height: 2000m

Pollution degree: 2

Power: One 9V battery , NEDA 1604, IEC 6F22.

Dimensions: 182 (H) x 82 (W) x55 (D) mm

Weight: Approx. 375g.

Electrical Specifications

*Accuracy is given as \pm ([% of reading]+[number of least significant digits]) at 18° to 28° (65° F to 83° F) with relative humidity up to 70%.

RPM (Tach)

| Range | | Resolution | Accuracy |
|-----------|--------------------------|------------|----------------------|
| RPM 4 | 600~4000 RPM | 1 RPM | +2 % of rdg ± 4 dgts |
| | 1000~12000 RPM (X10 RPM) | 10 RPM | |
| RPM 2/DIS | 300~4000 RPM | 1 RPM | |
| | 1000~6000 RPM (X10 RPM) | 10 RPM | |

Effect Reading: >600 RPM

DWELL ANGLE

| Cylinder | Range | Resolution | Accuracy |
|----------|---------|------------|-----------------------|
| 4CYL | 0~90.0° | 0.1° | ±2.0% of rdg ± 4 dgts |
| 5CYL | 0~72.0° | | |
| 6CYL | 0~60.0° | | |
| 8CYL | 0~45.0° | | |

DC Voltage

| Range | Resolution | Accuracy |
|---------|------------|-----------------------|
| 400.0mV | 0.1mV | +0.5% of rdg ± 2 dgts |
| 4.000V | 1mV | ±1.5% of rdg ± 2 dgts |
| 40.00V | 10mV | |
| 400.0V | 100mV | |
| 600V | 1V | +1.8% of rdg ± 2 dgts |

Input Impedance: 10MΩ

Electrical Specifications Continued

*Accuracy is given as \pm ([% of reading]+[number of least significant digits]) at 18° to 28° (65° F to 83° F) with relative humidity up to 70%.

AC Voltage

| Range | Resolution | Accuracy |
|--------|------------|-----------------------|
| 4.000V | 1mV | +1.0% of rdg + 3 dgts |
| 40.00V | 10mV | +1.5% of rdg ± 3 dgts |
| 400.0V | 100mV | |
| 600V | 1V | +2.0% of rdg + 4 dgts |

Input Impedance: 10M Ω .

Frequency Range: 50 to 60Hz

DC Current

| Range | Resolution | Accuracy |
|---------|------------|-----------------------|
| 40.00mA | 10uA | +1.5% of rdg ± 3 dgts |
| 400.0mA | 100uA | |
| 20A | 10mA | +2.5% of rdg ± 5 dgts |

Overload Protection: 0.5A / 250V and 20A / 250V Fuse.

Maximum Input: 400mA dc or 400mA ac rms on uA / mA ranges, 20A dc or ac rms on 20A range.

AC Current

| Range | Resolution | Accuracy |
|---------|------------|-----------------------|
| 40.00mA | 10uA | +1.8% of rdg ± 5 dgts |
| 400.0mA | 100uA | |
| 20A | 10mA | +3.0% of rdg + 7 dgts |

Overload Protection: 0.5A / 250V and 20A / 250V Fuse.

Frequency Range: 50 to 60 Hz

Maximum Input: 400mA dc or 400mA ac rms on uA / mA ranges, 20A dc or ac rms on 20A range.

Resistance

| Range | Resolution | Accuracy |
|-----------------|--------------|-----------------------|
| 400.0 Ω | 0.1 Ω | +1.2% of rdg ± 4 dgts |
| 4.000k Ω | 1 Ω | +1.0% of rdg ± 2 dgts |
| 40.00k Ω | 10 Ω | +1.2% of rdg ± 2 dgts |
| 400.0k Ω | 100 Ω | |
| 4.000M Ω | 1k Ω | |
| 40.00M Ω | 10k Ω | +2.0% of rdg + 3 dgts |

Electrical Specifications Continued

*Accuracy is given as \pm ([% of reading]+[number of least significant digits]) at 18° to 28° (65° F to 83° F) with relative humidity up to 70%.

Capacitance

| Range | Resolution | Accuracy |
|---------|------------|----------------------------------|
| 4.000nF | 1pF | $\pm 5.0\%$ of rdg ± 50 dgts |
| 40.00nF | 10pF | $\pm 5.0\%$ of rdg ± 7 dgts |
| 400.0nF | 0.1nF | $\pm 3.0\%$ of rdg ± 5 dgts |
| 4.000uF | 1nF | |
| 40.00uF | 10nF | |
| 400.0uF | 0.1uF | |
| 4.000mF | 0.001mF | $\pm 10\%$ of rdg ± 10 dgts |
| 40.00mF | 10.00mF | |

Frequency

| Range | Resolution | Sensitivity | Accuracy |
|----------|------------|-------------|---------------------------------|
| 4.000kHz | 1Hz | >5V RMS | $\pm 1.5\%$ of rdg ± 3 dgts |
| 40.00kHz | 10Hz | | |
| 400.0kHz | 100Hz | | |
| 40.00MHz | 1kHz | >10V RMS | $\pm 2.0\%$ of rdg ± 4 dgts |

Duty Cycle

| Range | Resolution | Accuracy |
|------------|------------|-------------------------------|
| 0.1%~99.9% | 0.1% | $\pm 2\%$ of rdg ± 2 dgts |

Pulse width: >100us, <100ms;

Frequency width: 5Hz – 100kHz

Sensitivity: >5V RMS

Pulse Width

| Range | Resolution | Accuracy |
|-------------|------------|--------------------------------|
| 1.0~ 20.0ms | 0.1ms | $\pm 2\%$ of rdg ± 20 dgts |

Electrical Specifications Continued

*Accuracy is given as \pm ([% of reading]+[number of least significant digits]) at 18° to 28° (65° F to 83° F) with relative humidity up to 70%.

Type-K Temperature

| Range | Resolution | Accuracy |
|----------------|------------|--|
| -30°C~ 1000°C | 1 °C | \pm 3% of rdg \pm 5 °C/8 °F (Meter only, probe accuracy not included) |
| -22 °F~1832 °F | 1°F | |

Sensor: Type K Thermocouple

Diode Test

| Test current | Resolution | Accuracy |
|---------------|------------|-------------------------------|
| 1.0mA typical | 1 mV | \pm 5% of rdg \pm 15 dgts |

Open circuit voltage: 3.0V dc typical

Audible continuity

Audible threshold: Less than 35Ω Test current: <1mA dc typical

Maintenance

REPLACING THE BATTERY

WARNING: To avoid electric shock, disconnect the test leads from any source of voltage before removing the battery door.

1. When the batteries become exhausted or drop below the operating voltage, "BAT" will appear in the right-hand side of the LCD display. The battery should be replaced.
2. Follow instructions for installing battery. See the Battery Installation section of this manual.
3. Dispose of the old battery properly.

WARNING: To avoid electric shock, do not operate your meter until the battery door is in place and fastened securely.

BATTERY INSTALLATION

WARNING: To avoid electric shock, disconnect the test leads from any source of voltage before removing the battery door.

1. Disconnect the test leads from the meter.
2. Open the battery door by loosening the screw using a Phillips head screwdriver.
3. Insert the battery into battery holder, observing the correct polarity.
4. Put the battery door back in place. Secure with the two screws.

WARNING: To avoid electric shock, do not operate the meter until the battery door is in place and fastened securely.

NOTE: If your meter does not work properly, check the fuses and battery to make sure that they are still good and that they are properly inserted.

REPLACING THE FUSES

WARNING: To avoid electric shock, disconnect the test leads from any source of voltage before removing the rear cover (fuse door).

1. Disconnect the test leads from the meter and any item under test.
2. Open the fuse door by loosening the screws on the rear cover using a Phillips head screwdriver.
3. Remove the old fuse from its holder by gently pulling it out.
3. Install the new fuse into the holder.
4. Always use a fuse of the proper size and value (0.5A/250V - ϕ 5 x 20 , fast blow for the 400mA range, 20A/250V - ϕ 6.3 x 32 fast blow for the 20A range).
5. Put the fuse door back in place. Insert the screw and tighten it securely.

WARNING: To avoid electric shock, do not operate your meter until the fuse door is in place and fastened securely.

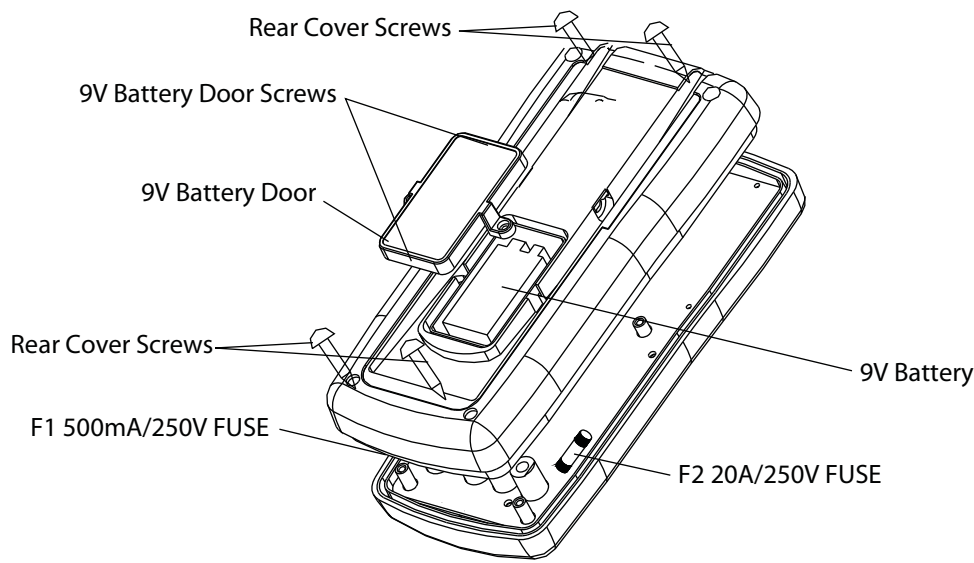

Troubleshooting

1. Meter will not turn ON.

- Check the battery contacts for a tight fit.
- Check for a minimum battery voltage of 8.0 volts.

2. Ampere reading is erratic or there is no reading at all.

- Disassemble the meter back cover as per the fuse replacement instructions on page 36 and test the fuses for continuity with another meter.

3. Meter reading is erratic.

- Printed circuit board damaged from handling with hands.
- Low battery.
- "Blown" fuse.
- Open circuit in a test lead (frayed or broken wire).

4. Meter readings do not change.

- "Hold" feature is still toggled ON.



WARRANTY

1 YEAR LIMITED WARRANTY

THIS WARRANTY AND CONFIRMED RECEIPT(S) SHOULD BE RETAINED BY THE CUSTOMER AT ALL TIMES

PURCHASED FROM: _____

DATE PURCHASED: _____

INVOICE/RECEIPT NUMBER: _____

Your ATD-5585 is warranted for a period of 12 months from the original purchase date.

For a period of one (1) year from your purchase date, ATD Tools Inc. will repair or replace (at its option) without charge, your ATD product if it was purchased new and the product has failed due to a defect in material or workmanship which you experienced during normal use of the product. This limited warranty is your exclusive remedy.

To access the benefits of this warranty, contact your supplier, or point of sale directly. You may be advised to return the product under warranty, freight prepaid, to your supplier for warranty determination.

If this ATD product is altered, abused, misused, modified, or undergoes service by an unauthorized technician, your warranty will be void. We are not responsible for damage to ornamental designs you place on this ATD product and such ornamentation should not cover any warnings or instructions or they may void the warranty. This warranty does not cover scratches, superficial dents, and other abrasions to the paint finish that occur under normal use. It also does not cover normal wear items such as but not limited to brushes, batteries, drill bits, drill chucks, pads or blades.

Subject to the law in your state:

- (1) Your sole and exclusive remedy is repair or replacement of the defective product as described above.
- (2) ATD is not liable for any incidental damages, including but not limited to, lost profits and unforeseeable consequences.
- (3) The repair and replacement of this product under the express limited warranty described above is your exclusive remedy and is provided in lieu of all other warranties, express or implied. All other warranties, including implied warranties and warranties of merchantability or fitness for a particular purpose are disclaimed and, if disclaimer is prohibited, these warranties are limited to one year from your date of purchase of this product.

Some states' laws do not allow limited durations on certain implied warranties and some states' laws do not allow limitations on incidental or consequential damages. You should consult the law in your state to determine how your rights may vary.

NOTE: This one year warranty does not cover dead batteries and blown fuses.

For warranty and service coverage, please return this product to your dealer for processing and evaluation as described above OR, return it directly to:

Electronic Specialties, Inc.
139 Elizabeth Ln.
Genoa City, WI 53128
262-279-1400
WWW.ESITEST.COM

Defective units being returned to your dealer or to the factory should include proof of purchase date.
Any testers that do not function due to misuse or abuse will be subject to out of warranty service charges.