



ATD-5570 Deluxe Automotive Meter with RPM and Temperature Functions Owner's Manual



Features:

- (45) Test ranges
- (14) Test functions
- Displays rpm for DIS and standard ignitions
- Dual display with analog bar graph and digital readings
- Built-in temperature readings
- Includes rpm pick-up and temperature probe
- 10 Meg/Ohm input impedance
- Dual fuse protection
- Safety leads and jacks
- Built-in tilt stand

Contents

Safety.....	3
Getting Started.....	4
Meter Basics.....	4
Digital and Analog Display.....	9
Function and Range Select.....	10
Push Button Functions.....	11
Alternate Function Button.....	11
Range Select.....	11
Range Exit.....	11
Data Hold.....	11

Meter Functions

Voltage.....	12
Resistance.....	13
Diode Check.....	14
Audible Continuity.....	15
AC or DC Current.....	16
Temperature.....	17
Frequency.....	18
Dwell.....	19
Duty Cycle.....	20
RPM.....	21

Maintenance

Fuse and Battery Replacement.....	23
Trouble Shooting.....	24
General Specifications.....	25
Electrical Specifications.....	26
Warranty Information.....	28

Safety

DANGER

- Engines produce carbon monoxide which is odorless, causes slower reaction time, and can lead to serious injury. When the engine is operating, keep service areas WELL VENTILATED or attach the vehicle exhaust system to the shop exhaust removal system.
- Set the parking brake and block the wheels before testing or repairing the vehicle. It is especially important to block the wheels on front-wheel drive vehicles; the parking brake does not hold the drive wheels.
- Wear an eye shield when testing or repairing vehicles.
- Exceeding the limits of this meter is dangerous. It will expose you to serious or possibly fatal injury. Carefully read and understand the cautions and the specification limits of this meter.
- Voltage between any terminal and ground must not exceed 1000V DC or 750V AC.
- Use caution when measuring voltage above 25V DC or 25V AC.
- Circuit tested must be protected by a 10A fuse or circuit breaker.
- Do not use the meter if it has been damaged.
- Do not use the test leads if the insulation is damaged or if metal is exposed.
- Avoid electrical shock: do not touch the test leads, tips or the circuit being tested.
- Do not try a voltage measurement with the test leads in the 10A or the mA terminal.
- When testing for the presence of voltage or current, make sure the meter is functioning correctly. Take a reading of a known voltage or current before accepting a zero reading.
- Choose the proper range and function for the measurement. Do not try voltage or current measurements that may exceed the ratings marked on the Function/Range switch or terminal.
- When measuring current, connect the meter in series with the load.
- Never connect more than one set of test leads to the meter.
- Disconnect the live test lead before disconnecting the common test lead.
- The mA and the 10A terminals are protected by fuses. To avoid possible injury or damage, use only in circuits limited to 320mA or 10A for 60 seconds.

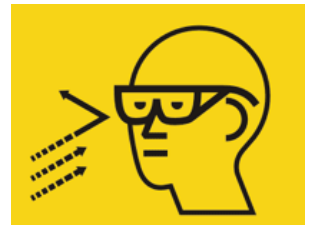

IMPORTANT

- To maintain accuracy of the meter, replace the discharged battery immediately when the battery symbol appears on the meter display.
- Avoid measuring error from outside interference - keep the meter away from spark plug or coil wires.
- Avoid damaging the meter when testing voltage - disconnect the test leads from the test points before changing functions.
- Do not exceed the limits shown in the table below:

FUNCTION	Terminal	Input limit
AC Volts	V-Ω-RPM	750 Volts AC RMS
DC Volts		1000 Volts DC
Frequency		500 Volts AC/DC
Ohm (resistance)	V-Ω-RPM	250 Volts AC/DC
Diode		
AC/DC μA mA	μA/mA	320mA AC/DC
AC/DC 10A	10A	*10A AC/DC
RPM	V-Ω-RPM	500 Volts AC/DC
Duty Cycle (%)		
Dwell Angle		

- * 10 Amp measurement for 60 seconds maximum.
- Ohms can not be measured if voltage is present, ohms can be measured only in a non-powered circuit. However, the meter is protected to 250 volts.

Meter Basics

1. Digital and Analog display features:

- a. Symbols to identify function
- b. Four character digital display
- c. Analog bar graph

The digital display is best for stable input. The bar graph is best for rapidly changing input.

2. Function Buttons:

Press the button to select a function. A symbol will display to verify your choice.

3. Rotary Selector Switch:

Turn this switch to select a function or turn the meter OFF.

4. Temperature Terminal:

Insert the temperature probe in this terminal.

5. Test Lead Terminals:

The Black test lead is used in the common (COM) terminal for all tests. The Red test lead is used to measure Amps or Volts.

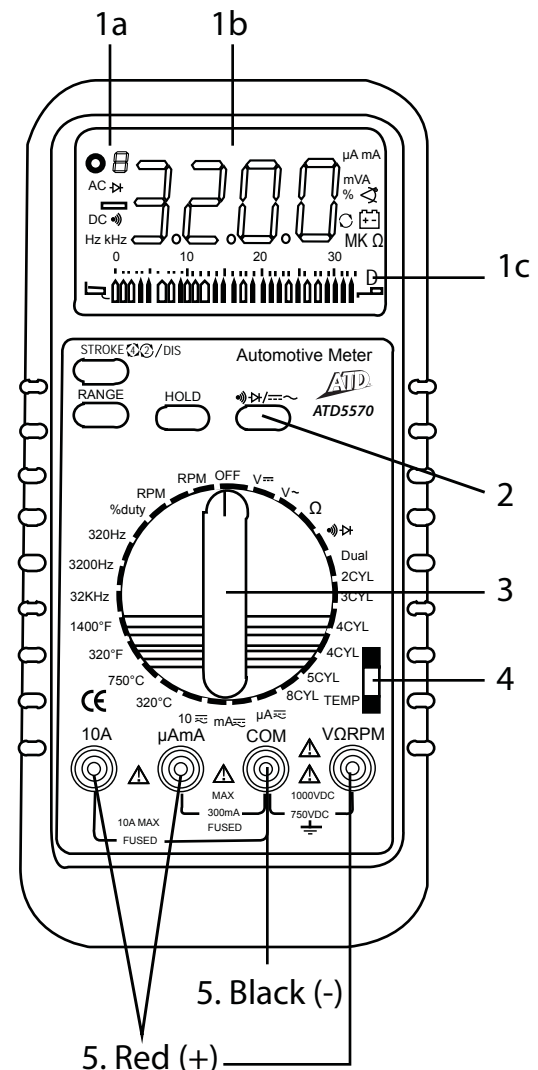

Digital and Analog Display

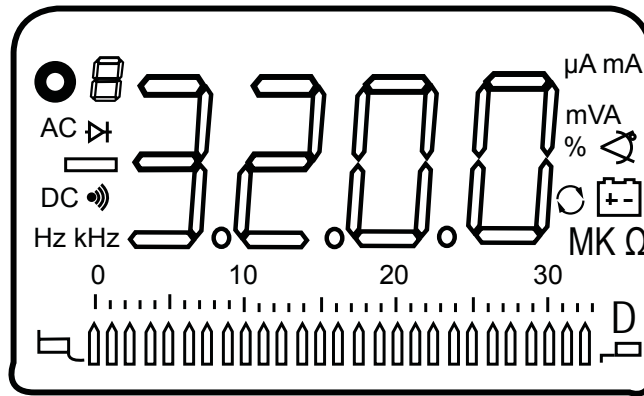

- Press **RANGE** button to manually select a range
- Press **Alt Function** button to select Alternating Current (AC) or Direct Current (DC)
- ⏸ Press **Hold** to hold data display or resume testing
- ⊖ **RPM** (Tach)
- ⏪ **Negative Polarity Indicator**
- 🔊 **Continuity Test**
- 🔍 When **Dwell** (# of cylinders) is selected with the rotary switch
- 🔋 **Low Battery** Replace the master battery when this symbol displays
- ⏮ **Analog Bar Graph Display with Polarity**

Units of measure:

- Kilo (k=1,000)
- Hertz (Hz)
- Milli (m=1/1,000)
- Volts (V)
- mega (m=1,000,000)
- ohms (Ω)
- dwell degrees
- duty percent (%)

Function and Range Select

Turn the rotary switch in either direction to select a function. Most functions also have ranges. Always select a range higher than you expect the current or voltage to be. Then select a lower range if better accuracy is needed.

- If the range is too high, the readings are less accurate.
- If the range is too low, the meter shows **OL** (over limit).

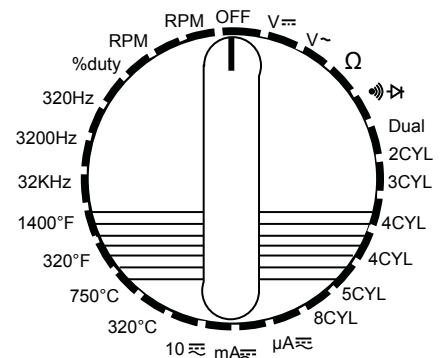

Push Button Functions

Alternate Function Button:

Press the **Alternate Function** button to toggle between DC and AC in the current measurements.

Range Select:

The range is automatically selected by the meter. You can also manually select a range within a function by pressing the **Range** button.

Range Exit:

To exit the **Range** mode and return to autoranging, press and hold the **Range** button for 2 seconds.

Note:

- If the range is too high, the readings are less accurate.
- If the range is too low, the meter shows OL (over limit).

Data Hold:

The **Data Hold** feature stores the last reading in memory. Press the **Data Hold** button once to hold the present reading. Press the **Data Hold** button again to exit and resume readings.

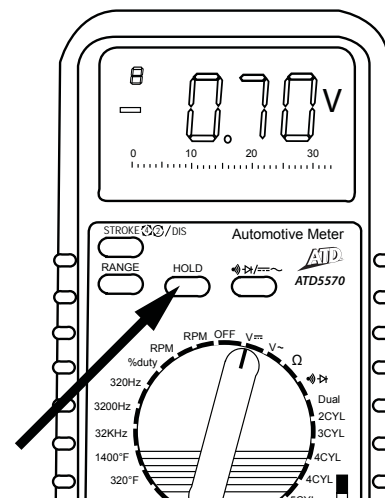
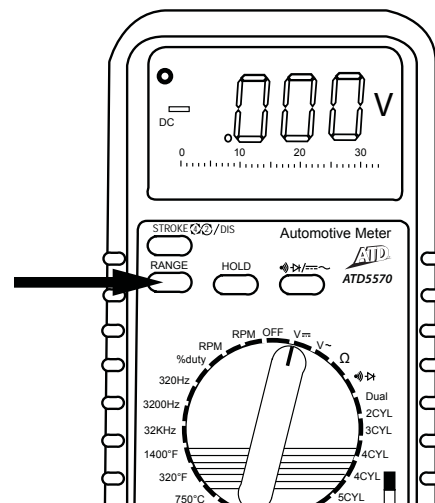
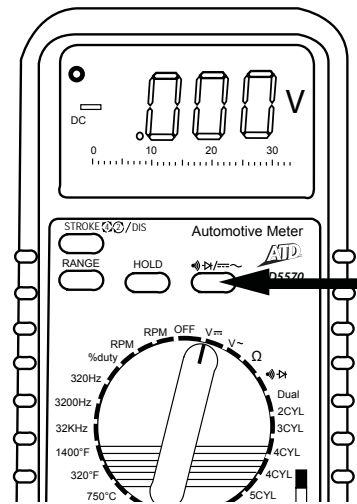

Meter Functions - Voltage (DCV)

The meter will automatically select the best **Voltage** (V) range.

Insert:

- Black lead in **COM** terminal.
- Red lead in **V-Ω-RPM** terminal.

Touch the Black probe to ground or to the negative (-) circuit.
Touch the Red probe to the circuit coming from the power source.

IMPORTANT: Voltage must be measured in parallel (Red probe measuring circuit from power source).

Accuracy

- Selection of a lower range will move the decimal point one place and increase the accuracy.
- An "OL" display means the range is too low, select the next higher range.

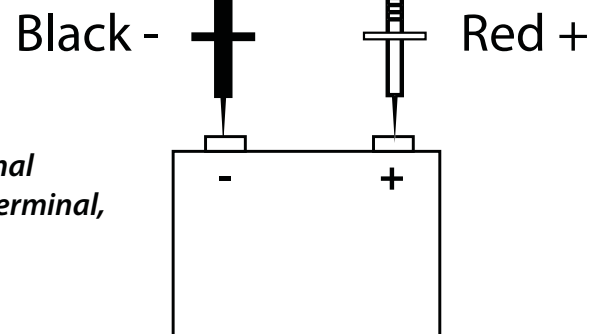
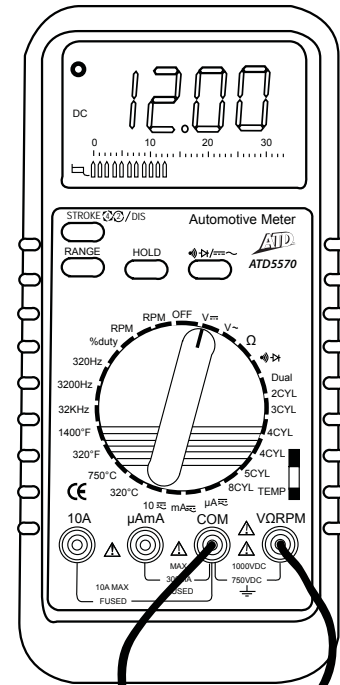

! WARNING

When measuring voltage, be sure the red test lead is in the terminal marked "V". If the test lead is in an Amp (A) or Milliampere (mA) terminal, you may be injured or the meter may be damaged.

Meter Functions - Resistance (Ω)

IMPORTANT: If you are testing an application that has capacitors in the circuit, be sure to turn the power OFF on the test circuit and discharge all capacitors. Accurate measurement is not possible if external or residual voltage is present.

- Select the **Resistance (Ω)** range with the rotary switch.

Select the **Resistance (Ω)** range with the button labeled **Range**, if more accurate measurement is desired.

Insert:

- Black lead in **COM** terminal.
 - Red lead in **V- Ω -RPM** terminal.
-
- Touch the test lead probes across the resistor to be tested.

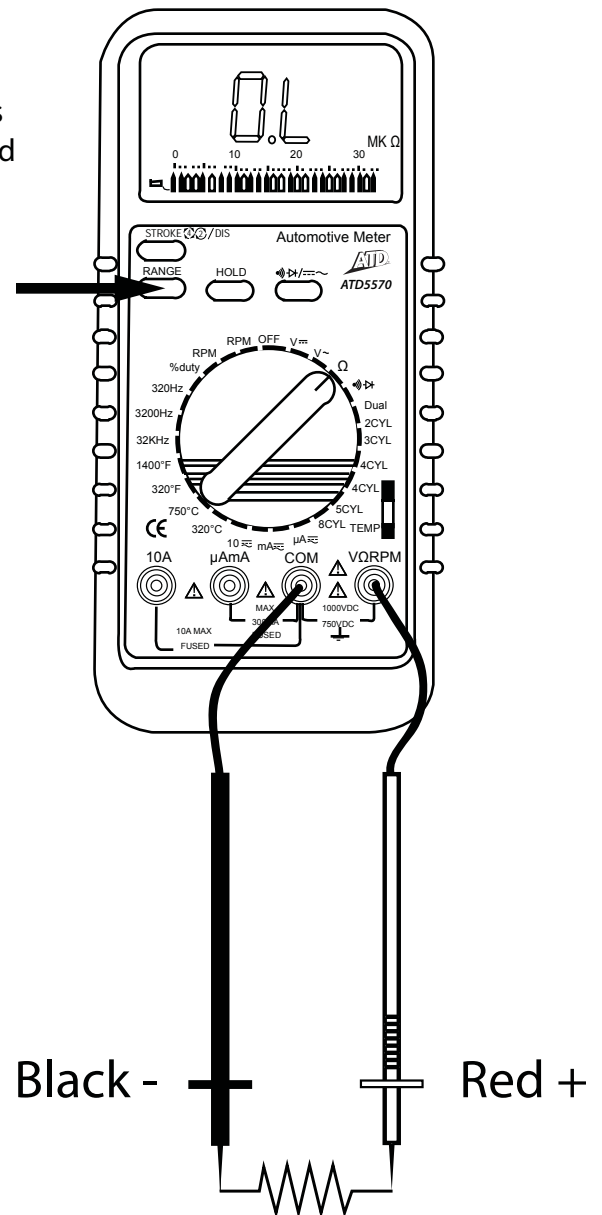

Meter Functions – Diode Check ()

IMPORTANT: Turn the power OFF to the test circuit

- Select the **Diode Check** () setting with the rotary switch.

Insert:

- Black lead in **COM** terminal.
- Red lead in **V-Ω-RPM** terminal.

Touch the Black test probe to the negative (-) side of the diode.

Touch the Red test probe to the positive (+) side of the diode.

Reverse the probes : Black to the positive (+) side and Red to the negative (-) side.

Note:

A good diode will read low in one direction and high in the other direction when the probes are reversed (or vice versa). A defective diode will have the same reading in both directions or read between 1.0 to 3.0V. in both directions.

Diode	(-) to (+)	Reverse Probes (-) to (+)
Good	.4 to .9V	OL
	OL	.4 to .9V
Bad	OL	1.0 to 3.0V
	1.0 to 3.0V	OL
	.4 to .9V	.4 to .9V
	OL	OL
	.000V	.000V

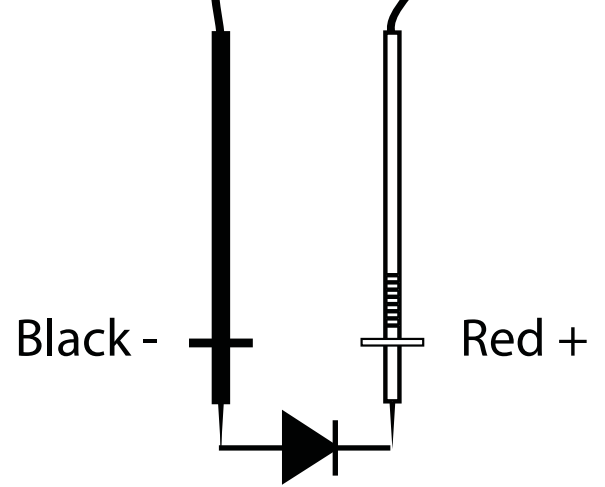
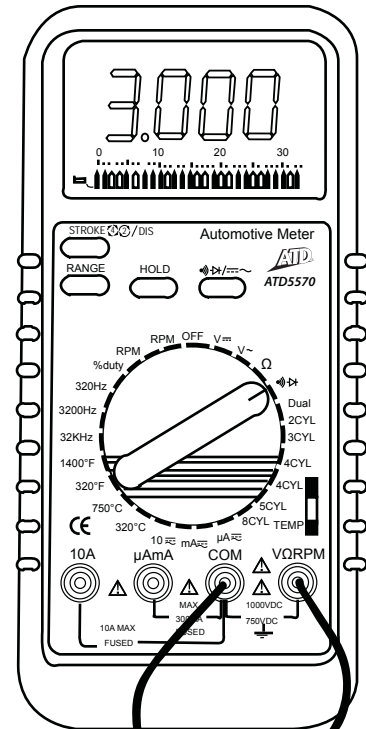

Meter Functions – Audible Continuity (•)))

IMPORTANT: Turn the power OFF to the test circuit

Select the **Audible Continuity** (•))) setting with the rotary switch.

Insert:

- Black lead in **COM** terminal.
- Red lead in **V-Ω-RPM** terminal.

Touch one test probe to each end of the circuit to be tested.

If the circuit is complete, the meter will beep continuously.

If the circuit is open, there will be no beep and the display will show "1" (over limit).

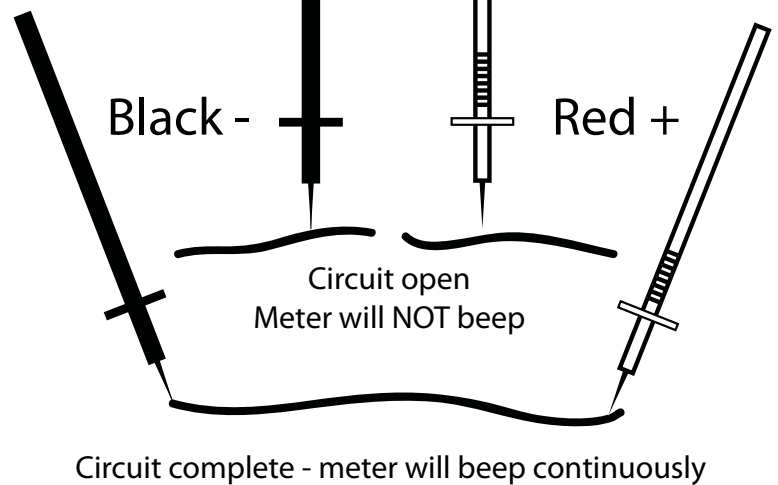
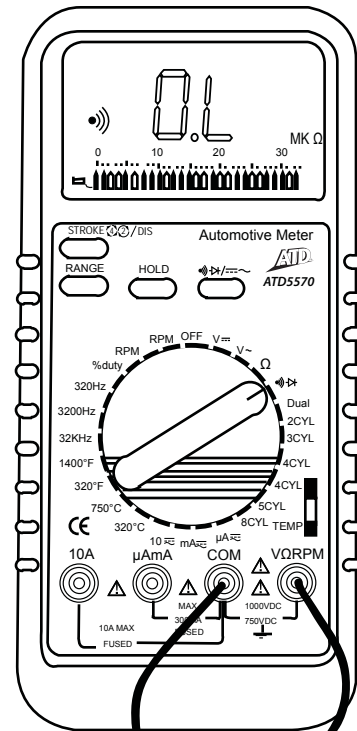

Meter Functions – AC or DC Current (A)

IMPORTANT: All current measured flows through the meter. It is important that you **DO NOT**:

- Measure current greater than 600V AC or DC, with respect to ground.
- Exceed 60 seconds when measuring continuous current between 1-10 Amps. Allow five minutes for cool down before continuing.

To Measure:

- Select the 10A, mA or μ A range with the rotary switch.
- Press the **Alternate Function** button to select AC or DC.

Insert:

- Black lead in **COM** terminal.
- Red lead in the 10A or mA terminal. (Select the 10A terminal if you are unsure of the current draw).

IMPORTANT:

Turn OFF all power to the circuit or disconnect the circuit from the power source.

Connect:

- The Red probe to the side of the circuit closest to the power source.
- The Black probe to the side of the circuit to ground.
- Turn the power ON and test.

Note:

Current must always be measured with the meter test probes connected in series as described.

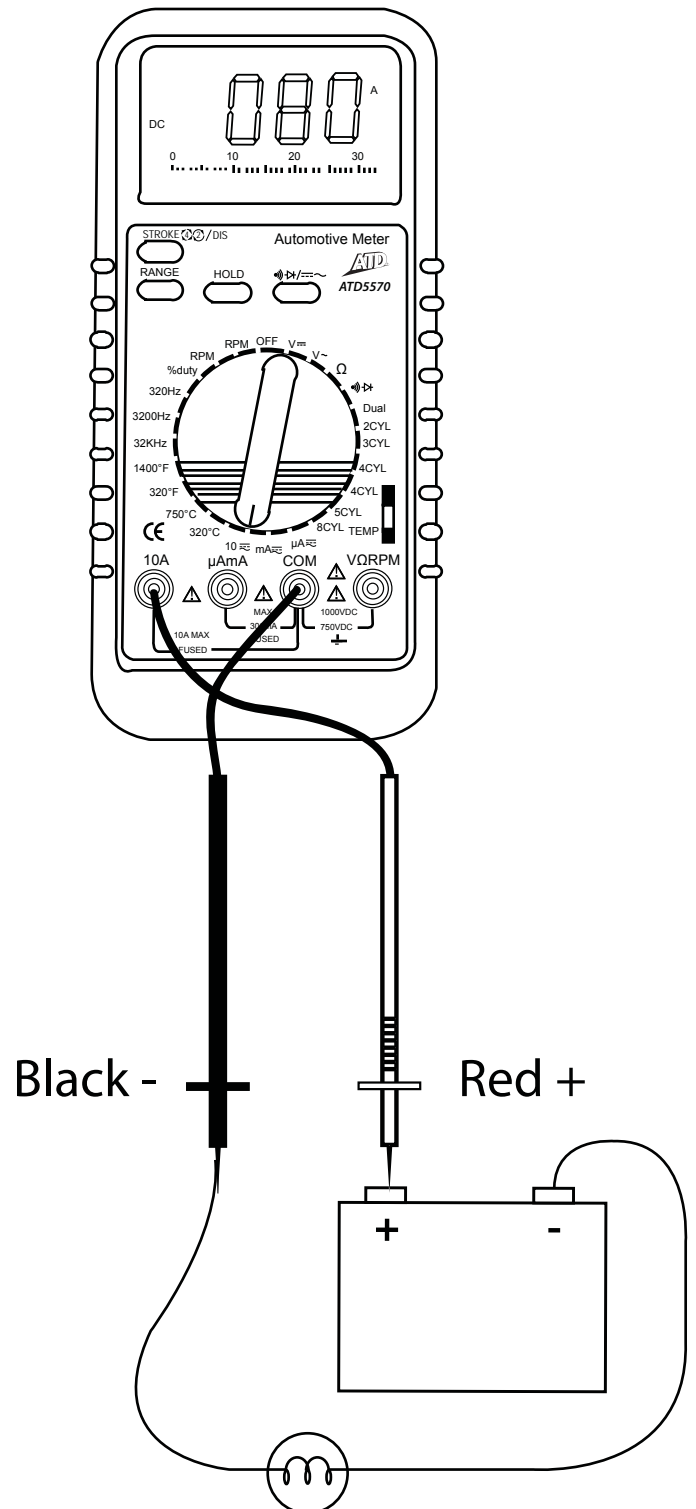

Meter Functions – Temperature (°C / °F)

IMPORTANT: To avoid heat damage to the meter, keep it away from sources of very high temperature. The life of the temperature probe is also reduced when subjected to very high temperatures. Probe operating range is -4° to $1,400^{\circ}$ F.

- Select the **Temperature** unit of measure with the rotary switch (°C / °F).
- Insert the temperature probe connector into the K-type thermocouple socket.
- Touch the end of the temperature sensor to the area or surface of the object to be measured.

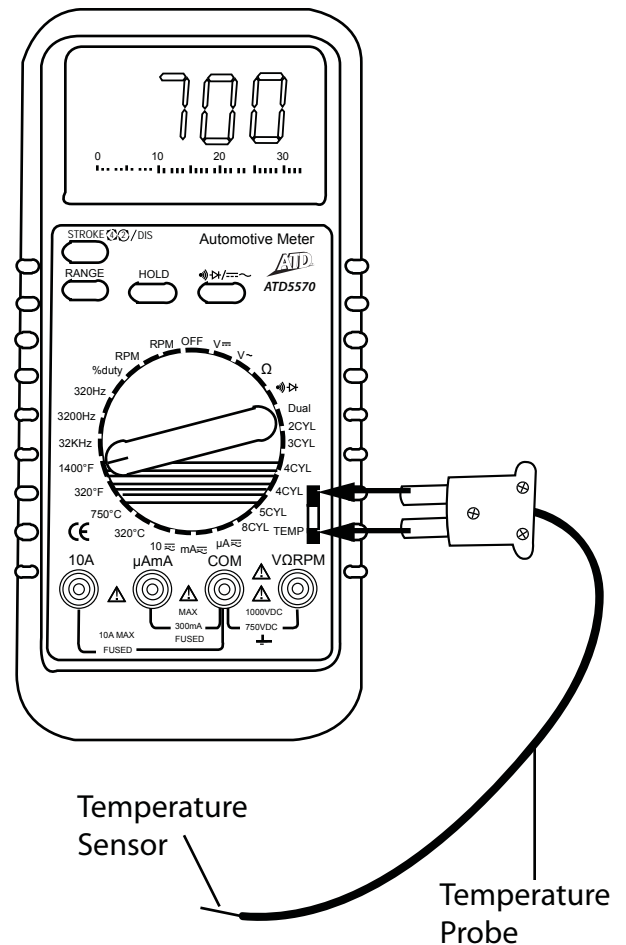

Meter Functions – Frequency (Hz)

- Select the **Frequency (FREQ)** setting with the rotary switch.
- Set the rotary switch to the frequency range that gives the most accurate measurement reading.

Insert:

- Black lead in **COM** terminal
- Red lead in **V-Ω-RPM** terminal.

Connect the Black test probe to ground.

Connect the Red test probe to the **Signal Out** wire of the sensor to be tested.

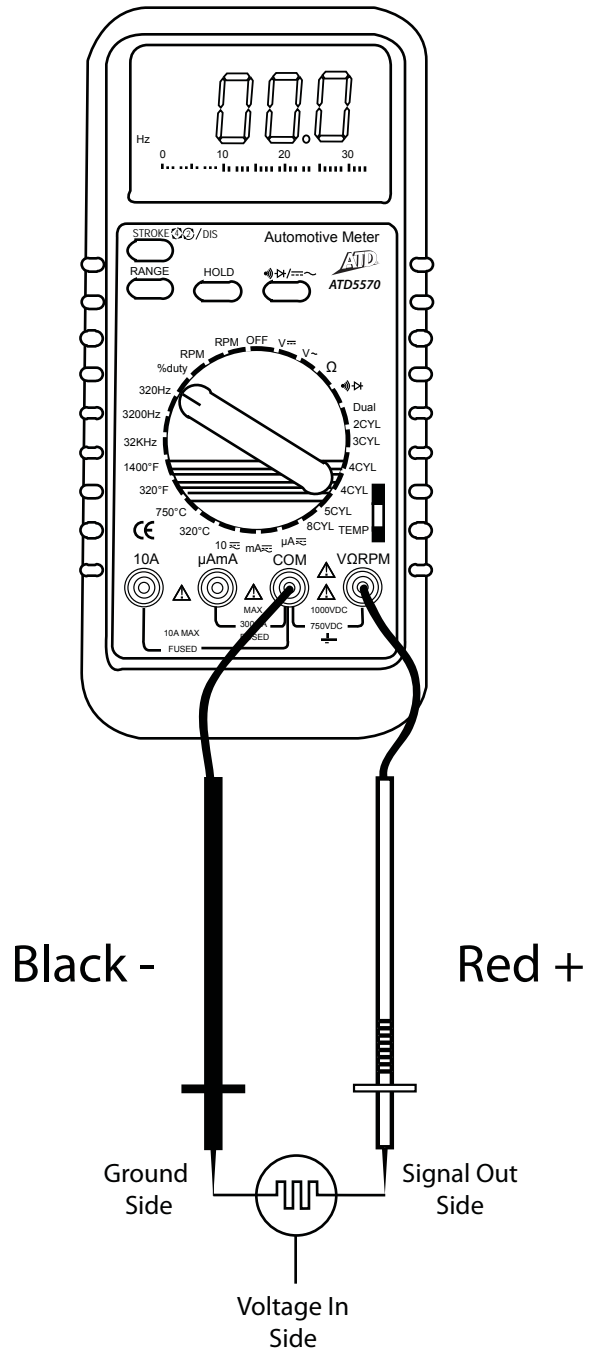

Meter Functions – Dwell

- Select the proper **Dwell** range with the rotary switch.

Insert:

- Black lead in **COM** terminal
- Red lead in **V-Ω-RPM** terminal.

Connect the Black test probe to ground.

Connect the Red test probe to the wire that connects to the breaker points (see illustration).

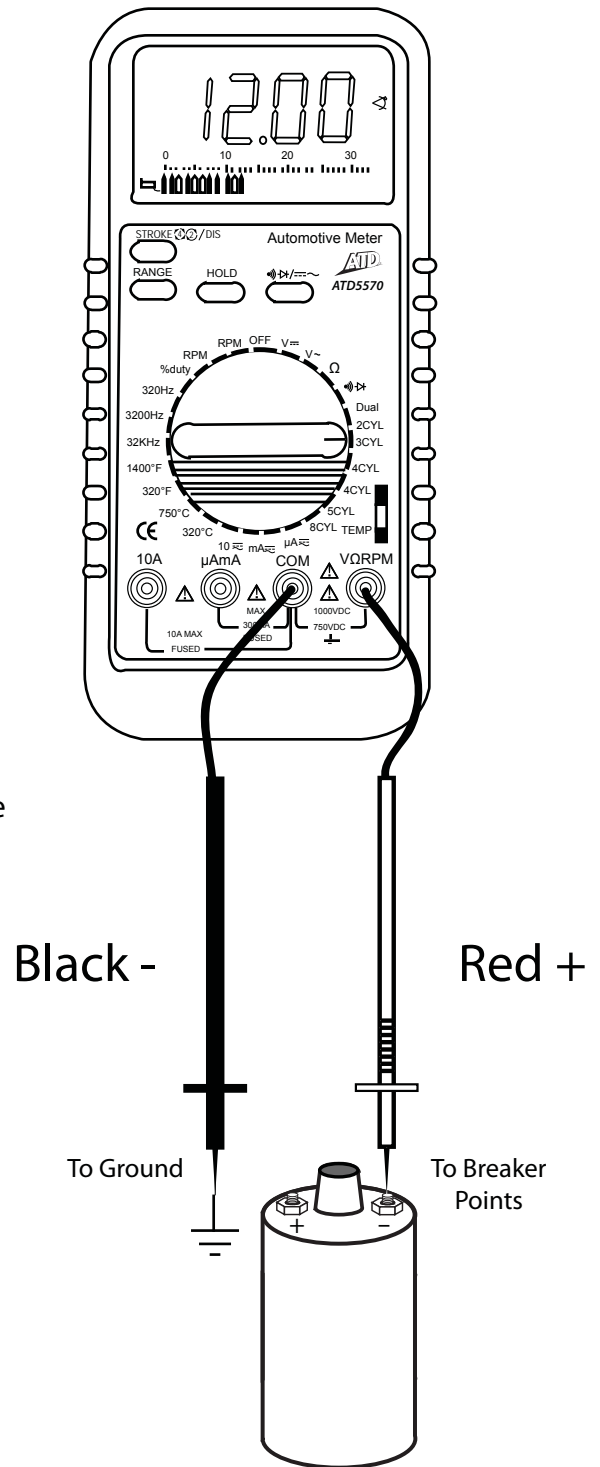

Meter Functions – Duty Cycle (%)

- Select the % **Duty Cycle** range with the rotary switch.

Insert:

- Black lead in **COM** terminal
- Red lead in **V-Ω-RPM** terminal.

Connect the Black test probe to ground.

Connect the Red test probe to the signal wire circuit (see illustration).

The illustration for a mixture control solenoid is shown with the metering rod in the closed position. The meter will display the percentage of time the plunger is in the closed position (low duty cycle) during one duty cycle.

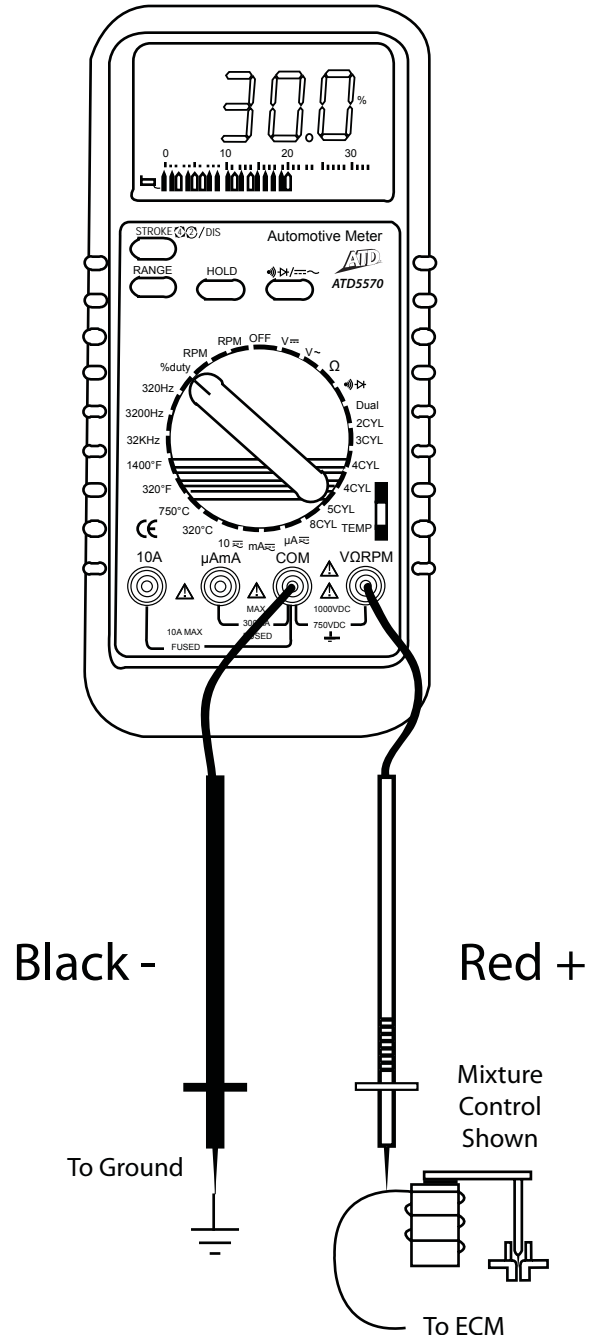

Meter Functions – RPM / x10 RPM

- Select the **RPM** range with the rotary switch.

OR

- Select the **x10 RPM** range with the rotary switch (1,000 to 12,000 rpm). Multiply the displayed reading times by 10 to get actual rpm.

Press **STROKE** button and cycle through RPM 4 for 4-stroke, RPM 2 for 2-stroke and DIS/DIS.

- Insert the inductive pickup connecting terminal into the meter.

- Ground lead in **COM** terminal.
- Output lead in **V-Ω-RPM** terminal.

- Connect the inductive pickup to a spark plug wire. If no reading is received, unhook the clamp, turn it over and connect again.

Note:

- Position the inductive pick-up as far away from the distributor and the exhaust manifold as possible.
- Position the inductive pick-up to within six inches of the spark plug or move it to another plug wire if no reading or an erratic reading is received.

RPM 4: For rpm of 4-stroke engines which have 1 ignition on every 4 engine strokes

RPM 2: For RPM of DIS and 2-stroke engines which have 1 ignition on every 2 engine strokes

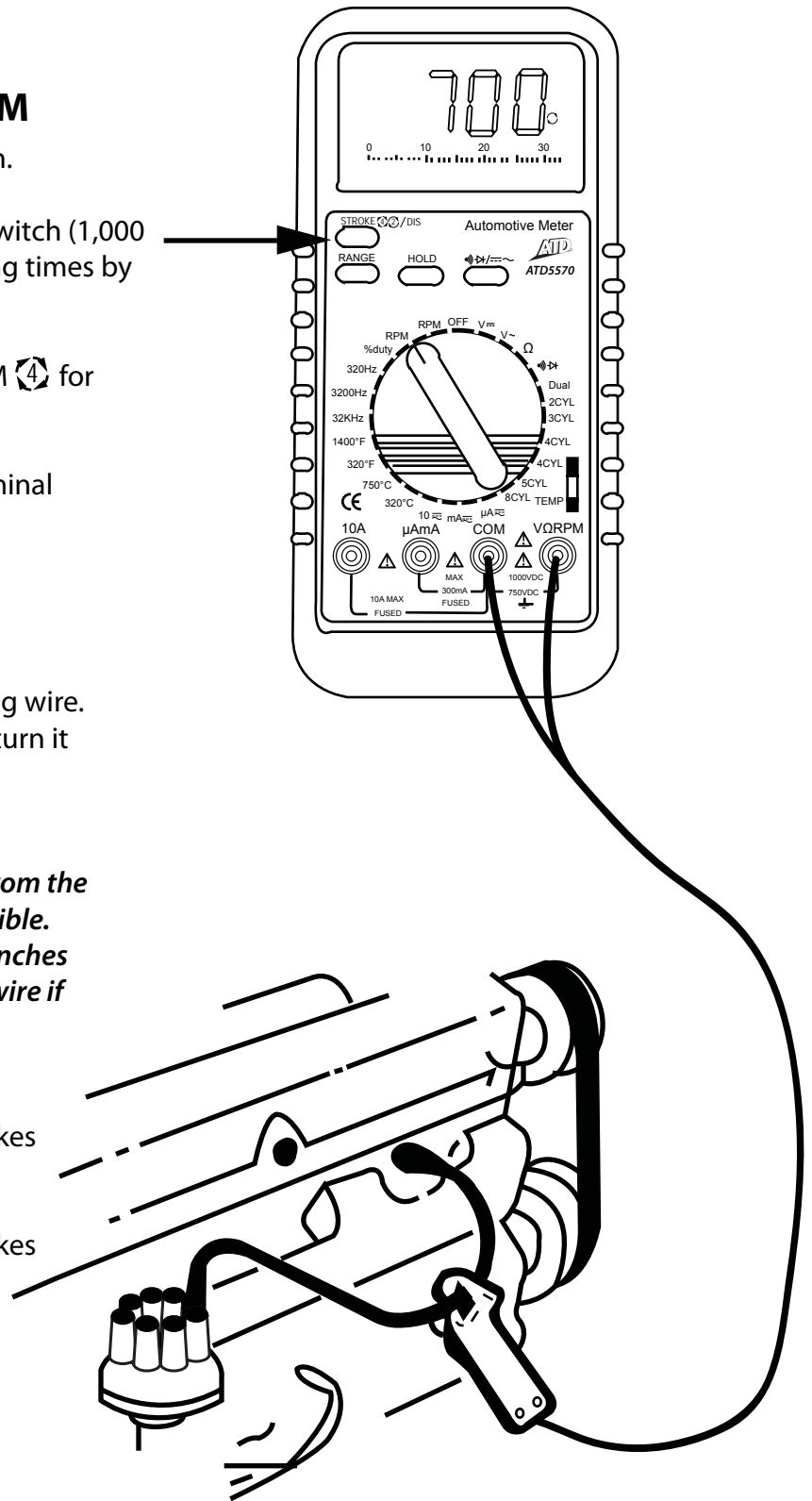

Maintenance

Fuse and Battery Replacement



- Avoid electrical shock: **REMOVE TEST LEADS BEFORE OPENING CASE!**
 - Do not operate the meter or rotate the meter switch when the case is open.
1. To replace a battery or fuse, remove red rubber protective case, then loosen the three screws in the case back and remove the case by lifting up and forward.

2. Replace the battery with an 9V alkaline battery.

Important:

- To prevent contamination of the circuits, your hands must be clean and the printed circuit board must be held by the edges.
- Replace the fuses with the same type of fuse.
- The 10A fuse is rated at 250V and is a high energy, fast acting fuse.
- The 500mA is a 250V fast acting fuse.
- Make sure the replacement fuse is centered in the fuse holder.

3. Re-assemble the case. Fasten the three screws and slide meter back into it's red rubber protective case.

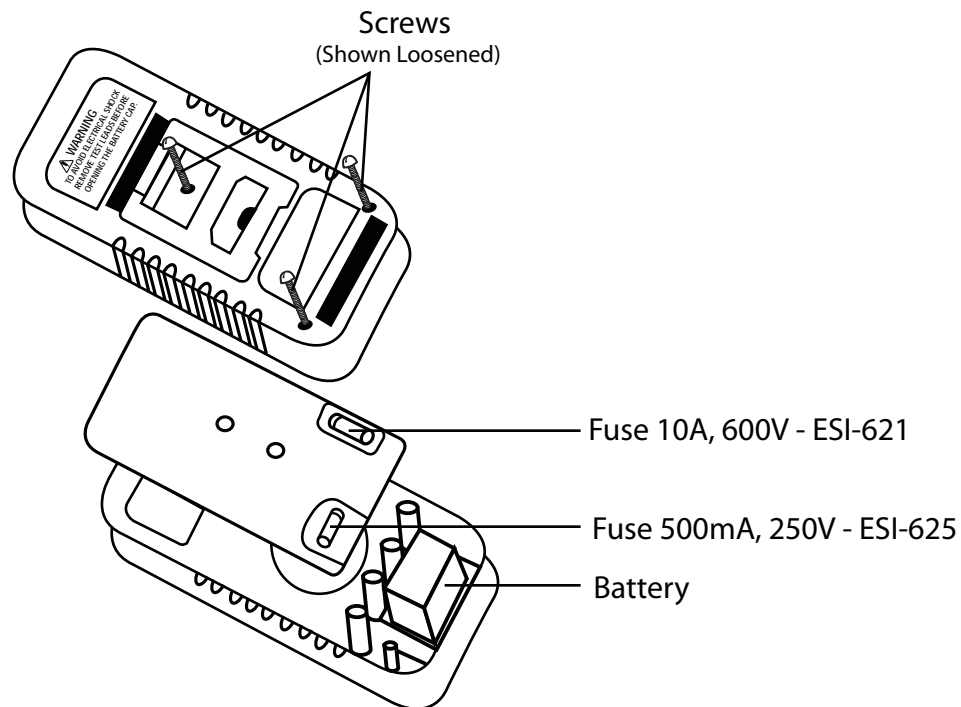

Troubleshooting

1. Meter will not turn ON.

- Check the battery contacts for a tight fit.
- Check for a minimum battery voltage of 8.0 volts.

2. Ampere reading is erratic or there is no reading at all.

- Disassemble the meter back cover and test the fuses for continuity.

3. Meter reading is erratic.

- Printed circuit board contaminated from handling with hands.
- Low battery.
- Open circuit in a test lead (frayed or broken wire).
- Wrong range selected.
- Blown fuse.

4. Meter readings do not change.

- **Hold** feature is still toggled ON.

GENERAL SPECIFICATIONS:

- **Display:** 3-1/2 digit (3200 counts) liquid crystal display (LCD), with function and units sign annunciators
- **Analog Bar Graph:** 34 segments with measurements 12 times per second
- **Polarity:** Automatic, (-) negative polarity indication
- **Over Range Indication:** "OL" mark indication
- **Low Battery Indication:** The  is displayed when the battery voltage drops below the operating level.
- **Measurement Rate:** 2 times per second, nominal.
- **Operating Environment:** 0° to 50° C (32° F to 122° F) at <70% R.H.
- **Storage Environment:** -20° to 60° C (-4° to 140° F) at <80% R.H.
- **Temperature Coefficient:** 0.2% (specified accuracy)/°C (<18° C or >28°C)
- **Power:** Single standard 9V battery (NEDA 1604 or IEC 6F22)
- **Battery Life:** 200 hours typical with alkaline battery
- **Fuses:** (1) 10A/250V, 6.3 × 25mm fast acting ceramic type
(2) 0.5A/250V, 5 × 20mm fast acting ceramic type
- **Dimensions:** 189mm H × 91mm W × 31.5mm D
- **Weight:** Approx. 280g (meter only), 450g (with holster)

ELECTRICAL SPECIFICATIONS:

*Accuracy is given as \pm ([% of reading] + [number of least significant digits]) at 18° C to 28° C (65° F to 83° F), with relative humidity up to 70%.

RPM (Tach):

Ranges (RPM 4): 600-3200, 6000-12000 ($\times 10$ RPM)

Ranges (RPM 2/DIS): 300-3200, 3000-6000 ($\times 10$ RPM)

Resolution: 1 rpm

Effect Reading: >600 rpm

Accuracy: \pm (2.0% rdg + 4 dgts)

Overload Protection: 500V DC or RMS AC

%DUTY CYCLE:

Ranges: 1.0% - 90.0%

Resolution: 0.1%

Pulse width: >100 μ s <100ms

Accuracy: \pm (2.0% rdg + 5 dgts)

Overload Protection: 500V DC or RMS AC

DWELL ANGLE:

NO. of cylinders: 2, 3, 4, 5, 6, 8

Ranges: 0-180.0° (2CYL), 0-120.0° (3CYL), 0-90.0° (4CYL), 0-72.0° (5CYL), 0-60.0° (6CYL), 0-45.0° (8CYL)

Resolution: 0.1°

Accuracy: \pm (2.0% rdg + 5 dgts)

Overload Protection: 500V DC or RMS AC

TEMPERATURE:

Ranges: -20.0 to 320°, -4.0 to 1400° F, -20 to 750°, -4 to 1400° F

Resolution: 0.1° C/0.1° F, 1° C/1° F

Accuracy: \pm (3.0% rdg + 2° C), \pm (3.0% rdg + 4° F)

Sensor: Type K Thermocouple

Input Protection: 60V DC or 24V AC RMS

DC VOLTAGE (Autoranging):

Ranges: 32mV, 3.2V, 32V, 320V, 1000V

Resolution: 100 μ V

Accuracy: \pm (1.2% rdg + 1 dgt)

Input Impedance: 10M Ω

Overload Protection: 1000V DC or 750V AC RMS

AC VOLTAGE (Autoranging):

Ranges: 3.2V, 32V, 320V, 750V

Resolution: 1mV

Accuracy: \pm (2.0% rdg + 4 dgts) at 50 Hz to 60 Hz

Input Impedance: 10M Ω

Overload Protection: 1000V DC or 750V AC RMS

ELECTRICAL SPECIFICATIONS CONTINUED...

CURRENT:

Ranges: 320 μ A, 3200 μ A, 32mA, 320mA, 10A

Resolution: 0.1 μ A

DC Accuracy: \pm (2.0% rdg +1 dgt) on μ A and mA ranges;

\pm (3.0% rdg + 3 dgts) on 10A range

AC Accuracy: \pm (2.5% rdg +4 dgts) on μ A and mA ranges;

\pm (3.5% rdg + 4 dgts) on 10A range

Frequency Response: 50Hz to 60Hz

Voltage Burden: 0.2V on 320 μ A, 32mA ranges;

2V on 3200 μ A, 320mA ranges

Input Protection: 0.5A/250V fast acting ceramic fuse on μ A/ mA input;

10A/250V fast acting ceramic fuse on 10A input

RESISTANCE (Autoranging):

Ranges: 320 Ω , 3.2 Ω ,32K Ω ,3.2M Ω , 32M Ω

Resolution:100m Ω

Accuracy: \pm (1.5% rdg +3 dgts) on 320 Ω to 320K Ω ranges;

\pm (2.5% rdg +3 dgts) on 3.2M Ω range;

\pm (5.0% rdg +5 dgts) on 32M Ω range

Overload Protection: 250V DC or RMS AC

FREQUENCY:

Ranges: 320Hz, 3200Hz, 32KHz

Resolution: 0.1Hz

Accuracy: \pm (1.0% rdg + 4 dgts) on all ranges

Sensitivity: 3.5V RMS min.at > 20% and < 80% duty cycle

Effect Reading: More than 100 digits at pulse width > 2 μ Sec

Overload Protection: 500V DC or RMS AC

DIODE TEST:

Test current: 0.6mA typical ($V_f=0.6V$)

Resolution: 1mA

Accuracy: \pm (10% rdg +3 dgts)

Open Circuit Voltage: 3.0V DC typical

Overload Protection: 250V DC or RMS AC

Audible Continuity

Audible Threshold: Less than 20 Ω

Resolution: 100m Ω

Test current: < 0.7mA

Overload Protection: 250V DC or RMS AC



WARRANTY

1 YEAR LIMITED WARRANTY

THIS WARRANTY AND CONFIRMED RECEIPT(S) SHOULD BE RETAINED BY THE CUSTOMER AT ALL TIMES

PURCHASED FROM: _____

DATE PURCHASED: _____

INVOICE/RECEIPT NUMBER: _____

Your ATD-5570 is warranted for a period of 12 months from the original purchase date.

For a period of one (1) year from your purchase date, ATD Tools Inc. will repair or replace (at its option) without charge, your ATD product if it was purchased new and the product has failed due to a defect in material or workmanship which you experienced during normal use of the product. This limited warranty is your exclusive remedy.

To access the benefits of this warranty, contact your supplier, or point of sale directly. You may be advised to return the product under warranty, freight prepaid, to your supplier for warranty determination.

If this ATD product is altered, abused, misused, modified, or undergoes service by an unauthorized technician, your warranty will be void. We are not responsible for damage to ornamental designs you place on this ATD product and such ornamentation should not cover any warnings or instructions or they may void the warranty. This warranty does not cover scratches, superficial dents, and other abrasions to the paint finish that occur under normal use. It also does not cover normal wear items such as but not limited to brushes, batteries, drill bits, drill chucks, pads or blades.

Subject to the law in your state:

- (1) Your sole and exclusive remedy is repair or replacement of the defective product as described above.
- (2) ATD is not liable for any incidental damages, including but not limited to, lost profits and unforeseeable consequences.
- (3) The repair and replacement of this product under the express limited warranty described above is your exclusive remedy and is provided in lieu of all other warranties, express or implied. All other warranties, including implied warranties and warranties of merchantability or fitness for a particular purpose are disclaimed and, if disclaimer is prohibited, these warranties are limited to one year from your date of purchase of this product.

Some states' laws do not allow limited durations on certain implied warranties and some states' laws do not allow limitations on incidental or consequential damages. You should consult the law in your state to determine how your rights may vary.

NOTE: This one year warranty does not cover dead batteries and blown fuses.

For warranty and service coverage, please return this product to your dealer for processing and evaluation as described above OR, return it directly to:

**Electronic Specialties, Inc.
139 Elizabeth Ln.
Genoa City, WI 53128
262-279-1400
WWW.ESITEST.COM**

Defective units being returned to your dealer or to the factory should include proof of purchase date. Any testers that do not function due to misuse or abuse will be subject to out of warranty service charges.