



ATD-5267 Dual Mode Pneumatic Grease Gun Owner's Manual



Features:

- Patented design allows fully automatic continuous flow or single shot grease discharge in one gun
- Supplied with 30" flexible grease hose and coupler
- 3-way loading: cartridge, drum or bulk
- Heavy-duty aluminum die cast head with precision honed internal bore
- Head fitted with bulk loader that doubles as an air bleeder
- Ergonomic pistol grip and accurate angle design for balance and ease of use
- For use with 14 oz. standard cartridges

Specifications:

- Air Operating Range: 40 to 150 psi
- Pressure Ratio: 40:1
- Air Compressor Volume: 1 CFM

Dual Mode Pneumatic Grease Gun

Pneumatic grease guns are ideal for applications requiring frequent greasing such as in automotive workshops, manufacturing facilities etc.

Patented design

Fully automatic free outflow and single shot / grease discharge on demand in one gun.

Designed for outstanding durability and dependability, this one gun eliminates the need to have two separate guns – continuous flow and single shot

Built Tough

- Heavy duty and durable Aluminium die cast head with precision honed internal bore. Head fitted with bulk loader that doubles as an air bleeder
- Ergonomic pistol grip and acute angle design for ease of use, especially in narrow work spaces
- Sturdy variable trigger mechanism to dispense grease
- Grease gun barrel in premium powder coated finish with clip mounted on the barrel for securing hose & coupler when not in use

Dual Mode

- Switch between fully automatic continuous grease flow operation and on demand /single shot operation, with the slide of an easy to use button

Also included

30" (760 mm) flexible grease hose & coupler



Slide backwards for Continuous Mode



Press button for Single Shot operation



Comes with 30" flexible hose with coupler

DEVELOPS	DELIVERS (ONE SHOT MODE)	DELIVERS (CONTINUOUS FLOW)
 <p>UP TO 6,000 PSI (413 BAR)</p>	<p>UP TO 0.90 GM / SHOT (1 .30 OZ. / 40 STROKES)</p>	<p>UP TO 400 GM / MIN (14 OZ./MIN)</p>

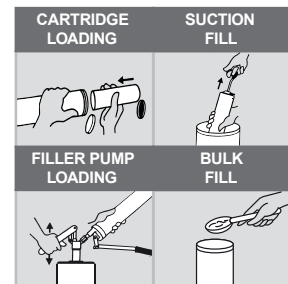

MODEL	CARTRIDGE CAPACITY		BULK CAPACITY	THREADS
	(OZ)	(GMS)	(CM ³)	DESCRIPTION
ATD-5267	14	400	500	1/8" NPT

SPECIFICATIONS

HANDLE STYLE	Pistol
AIR INLET THREADED	1/4" (F)
AIR INLET PRESSURE	40-150 PSI (3-10 bar)
PRESSURE RATIO	40:1
AIR CONSUMPTION	1 cfm /0.026 cbm

GREASE FILLING OPTIONS

CARTRIDGE LOADING	Yes
BULK FILL	Yes
SUCTION FILL	Yes
FILLER PUMP LOADING	Yes

SAFETY INFORMATION

- Follow workshop health & safety rules, regulations and conditions when using the grease gun.
- Use genuine parts only. Unauthorized parts may be dangerous and will void the warranty.
- Wear approved safety gloves and eye and ear protection.
- Keep the gun clean and in good working order for best and safest performance.
- **DO NOT** use the gun for a task it is not designed to perform.
- **DO NOT** carry the gun by flexible hose.
- When not in use, disconnect from air supply and store in a safe, dry, childproof location.

WARNING!

- **DO NOT** use grease gun if damaged or thought to be faulty. Contact your local service agent.
- Grease is delivered at high pressure. **DO NOT** point the grease outlet at yourself or others.

PACKAGE CONTENTS

DESCRIPTION	QUANTITY
Dual mode air operated grease gun	1
Flexible hose with grease coupler	1
Owner's Manual	1

TOOLS NEEDED

- 14 mm wrench / 9/16" wrench

BEFORE INSTALLATION

(Refer to "EXPLODED VIEW")

- Ensure that the trigger (9) is in the off position when connecting to the air supply.
- Dry air is needed to operate this gun. Make sure a FRL (Filter, Regulator, and Lubricator) unit is installed in the airline as moisture in the air will damage the grease gun.
- The compressor must have a minimum volume of 1 CFM (0.026 cubic meter).
- Line pressure should be increased to compensate for unusually long air hoses (over 25').

- Inlet air supply should have a pressure between 40-150 PSI (3-10 bar). This grease gun has a 40:1 pressure ratio; i.e. the grease discharge pressure will be 40 times the inlet air pressure.
- For lubrication of the grease gun, add a few drops of oil through the inlet valve (4) on the grease gun. It is recommended to use SAE 30 or greater grade oil.
- This grease gun comes with one standard inlet valve (4). The inlet valve (4) must fit properly onto the female quick connect coupler on the airline. If it does not fit properly, use a coupler that does.
- Keep hose away from heat, oil and sharp edges. Check hose for wear and make sure that all connections are secure.

WARNING!

- Defective accessories can lead to personal injury and material damage
- Disconnect from air supply before changing accessories or servicing.

INSTALLATION

(Refer to "EXPLODED VIEW")

Setting up the grease gun head

Note: Use P.T.F.E. tape while connecting flexible hose (10) to the grease gun head (2) and grease coupler (11) to the flexible hose (10).

1. Connect the flexible hose (10) to the outlet of grease gun.
2. Thread tighten the grease coupler (11) to other end of flexible hose (10).
3. All the connections should be tight.

CAUTION!

- Grease or empty cartridge in barrel is under pressure from the internal spring, be alert when removing the grease gun head.

Loading the grease gun

1. Make sure the gun is disconnected from the air supply.
2. Remove any cartridge in the grease gun barrel (3) prior to refilling.

- To check if a cartridge is in the grease gun barrel (3), first pull out the plunger handle (8) to its maximum distance and lock it in place.
- Remove the grease gun head (2) by turning it counter clockwise.
- Remove any empty cartridge.

Always follow the steps listed above in preparing to load your grease gun before proceeding to the appropriate loading method.

There are 4 ways to load this grease gun:

- Cartridge loading
- Bulk fill
- Suction fill
- Filler Pump loading

Cartridge loading

- Fully draw back the plunger handle (8) and lock it in place.
- Remove the grease gun head (2) from the grease gun barrel (3) by turning it counter clockwise.
- Insert the open end of the cartridge into the grease gun barrel (3) and push it all the way in.
- Remove the seal or pull tab end from the cartridge.
- Reassemble the grease gun head (2) to the grease gun barrel (3) by turning it clockwise.

Bulk fill

- Fully draw back the plunger handle (8) and lock it in place.
- Remove the grease gun head (2) from the grease gun barrel (3) by turning it counter clockwise.
- Fill the grease gun barrel (3) with grease using a spatula.
- Reassemble the grease gun head (2) to the grease gun barrel (3) by turning it clockwise.

Suction fill

- Remove the grease gun head (2) from the grease gun barrel (3) by turning it counter clockwise.
- Submerge the open end of the grease gun barrel (3) into grease bucket by approximately 2" and fully draw back the plunger handle (8) and lock it in place.
- Reassemble the grease gun head (2) to the grease gun barrel (3) by turning it clockwise.

Filler Pump loading

- Fully draw back the plunger handle (8) and lock it in place.
- Insert bulk loader valve (5) into filler pump socket.
- Operate the filler pump to fill the grease gun barrel (3).
- Disconnect the grease gun from the filler pump.

CAUTION!

- Do not apply excessive torque or over-tighten the grease gun head as this will apply undue stress to the die cast outlet and may cause it to fracture.

Removing Trapped Air

After filling grease gun, trapped air should be removed by following the below steps:

- After filling grease gun barrel (3) with grease by any of the above methods, reassemble the gun.
- Tap the bulk loader valve (5) that also acts as air release valve to release the trapped air.
- Move the plunger handle (8) forward and backward to remove any trapped air pockets.
- Tap the bulk loader valve (5) again to release the trapped air.
- The grease gun is now ready to use.

OPERATING INSTRUCTIONS

(Refer to "EXPLODED VIEW")

- Connect the air hose to the inlet valve (4) on the grease gun and start the air supply.
- For single shot operation (Grease discharge with every press of trigger (9))
 - Move the slider (6) to the position as shown in the figure by pressing the button (7).



- For continuous mode operation (Continuous grease discharge with the trigger (9) pressed)
 - Move the slider (6) to the position as shown in the figure by sliding it back.



- The grease coupler (11) provided at the end of the flexible hose (10) has a jaw type construction. The coupler jaws will snap on to a grease fitting and maintain a tight fit.
- When connecting the grease coupler (11) to the grease fitting, press the grease coupler (11) straight onto the grease fitting to form a snug fit.
- Start operating the grease gun with the grease coupler (11) as aligned to the grease fitting as possible.

7. Once greasing is completed, slightly tilt the grease coupler (11), twist and pull back.
8. The tilt and twist action will allow easy removal of the grease coupler (11) from the grease fitting.

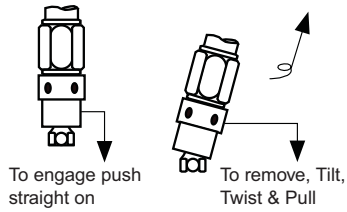

MAINTENANCE

(Refer to "EXPLODED VIEW")

- Grease gun and flexible hose (10) should be kept clean and checked for damage before each use.
- Use an air supply system that incorporates a filter, regulator, and lubricator, or add a few drops of lubricator oil (SAE 30 or greater) through the gun's inlet valve (4) in the body (1).

EXPLODED VIEW

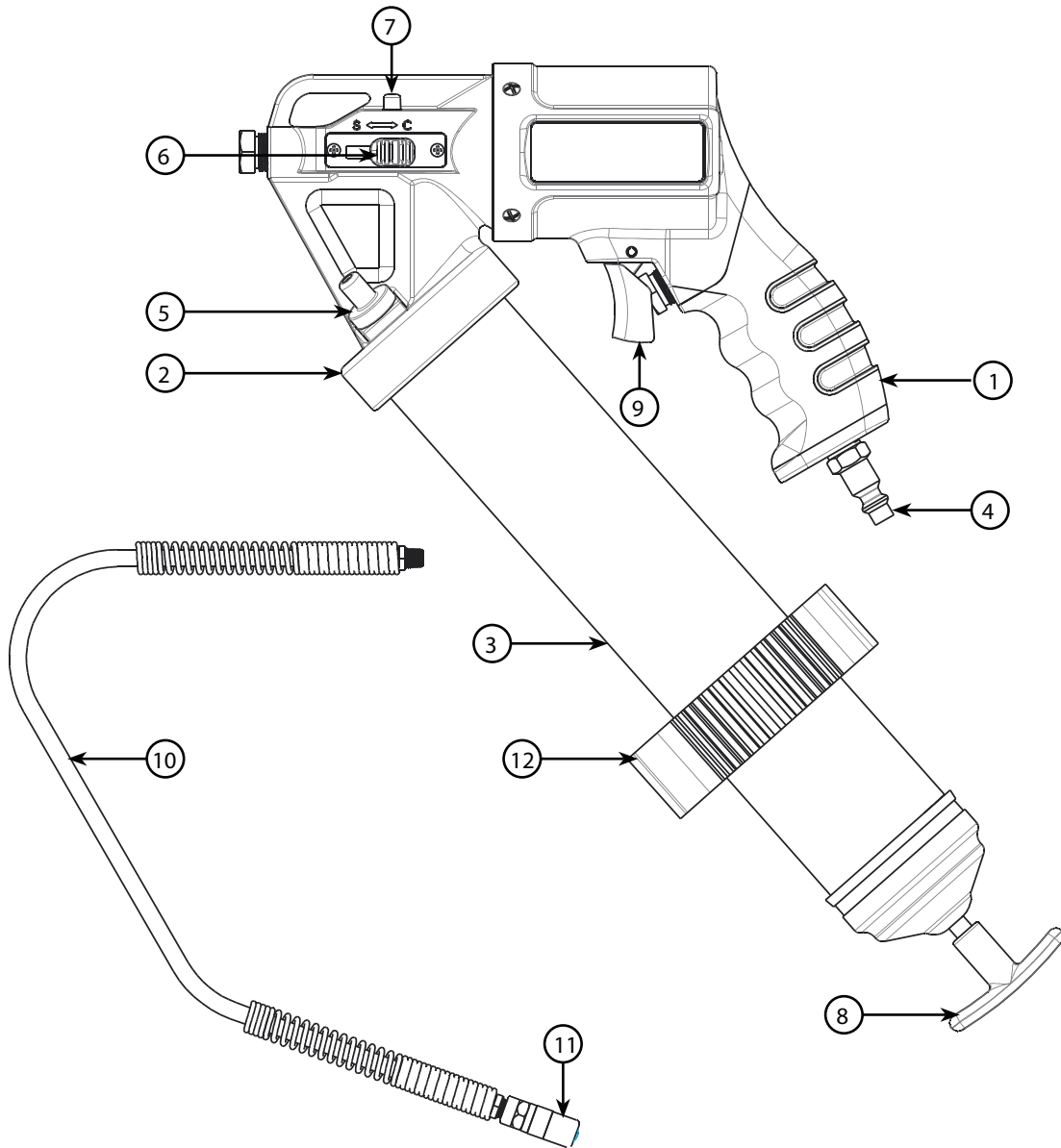

REPLACEMENT PARTS

Not all components of this product are replacement items, but are illustrated as a convenient reference for position in the assembly sequence. When ordering parts, give model number, part number and description. Call your distributor for current pricing:

ITEM#	ORDERING PART#	PART DESCRIPTION	QTY
1	PRT5267-01	BODY	1
2	PRT5267-02	GREASE GUN HEAD	1
3	PRT5267-03	GREASE GUN BARREL	1
4	PRT5267-04	INLET VALVE	1
5	PRT5267-05	BULK LOADER VALVE	1
6	PRT5267-06	SLIDER	1

ITEM#	ORDERING PART#	PART DESCRIPTION	QTY
7	PRT5267-07	BUTTON	1
8	PRT5267-08	PLUNGER HANDLE	1
9	PRT5267-09	TRIGGER	1
10	PRT5267-10	FLEXIBLE HOSE	1
11	PRT5267-11	GREASE COUPLER	1
12	PRT5267-12	CLIP	1

TROUBLESHOOTING

PROBLEM	POSSIBLE CAUSE	CORRECTIVE ACTION
Grease gun pumps little or no grease.	Barrel not completely tightened.	Tighten the barrel completely.
	Air Pockets are trapped in grease.	Remove air pocket by referring to "Removing Trapped Air" section
	Blocked flexible hose.	Remove the hose and operate the grease gun. If the gun dispenses grease then the gun is fine. Clean or replace the hose.
	Grease too thick or cold.	Store grease gun and grease away from extreme cold or use thinner grease.
	Defect in air motor.	Replace the defective part.
Excessive grease leaking past the follower	Follower is damaged.	Replace the grease gun.
	Improper seal between the plunger and the grease gun barrel	Replace the grease gun
Gun cycles very slowly	Inadequate lubrication of the pumping chamber	Put a few drops of lubricator oil through the inlet valve
If the gun still doesn't operate		Contact your ATD distributor

DISPOSAL

The components or the used products must be given to companies that specialize in the disposal and recycling of industrial waste.



ATD[®]

WARRANTY

1 YEAR LIMITED WARRANTY

THIS WARRANTY AND CONFIRMED RECEIPT(S) SHOULD BE RETAINED BY THE CUSTOMER AT ALL TIMES

PURCHASED FROM: _____

DATE PURCHASED: _____

INVOICE/RECEIPT NUMBER: _____

Your ATD-5267 is warranted for a period of 12 months from the original purchase date.

For a period of one (1) year from your purchase date, ATD Tools, Inc. will repair or replace (at its option) without charge, your ATD product if it was purchased new and the product has failed due to a defect in material or workmanship which you experienced during normal use of the product. This limited warranty is your exclusive remedy.

To access the benefits of this warranty, contact your supplier, or point of sale directly. You may be advised to return the product under warranty, freight prepaid, to your supplier for warranty determination.

If this ATD product is altered, abused, misused, modified, or undergoes service by an unauthorized technician, your warranty will be void. We are not responsible for damage to ornamental designs you place on this ATD product and such ornamentation should not cover any warnings or instructions or they may void the warranty. This warranty does not cover scratches, superficial dents, and other abrasions to the paint finish that occur under normal use. It also does not cover normal wear items such as but not limited to brushes, batteries, drill bits, drill chucks, pads or blades.

Subject to the law in your state:

- (1) Your sole and exclusive remedy is repair or replacement of the defective product as described above.
- (2) ATD is not liable for any incidental damages, including but not limited to, lost profits and unforeseeable consequences.
- (3) The repair and replacement of this product under the express limited warranty described above is your exclusive remedy and is provided in lieu of all other warranties, express or implied. All other warranties, including implied warranties and warranties of merchantability or fitness for a particular purpose are disclaimed and, if disclaimer is prohibited, these warranties are limited to one year from your date of purchase of this product.

Some states' laws do not allow limited durations on certain implied warranties and some states' laws do not allow limitations on incidental or consequential damages. You should consult the law in your state to determine how your rights may vary.

[Affix receipt or invoice here for safe keeping]

