



ATD-5062 Stainless Steel Vertical Lift Pump Owner's Manual

Self priming vertical lift pump with exceptional chemical resistance

Pump body made of 316 Stainless Steel

PTFE piston makes it suitable for use with wide variety of media

Pump includes a 2" bung adaptor with dual threads for use with metal and plastic drums

Integrated lock nut for attaching grounding wires

Designed for use with 55 gallon (205 liter) drums

Flow control tube can be inserted into lift handle to restrict the flow rate

WETTED COMPONENTS
316 Stainless Steel, PTFE

RECOMMENDED USE
Photographic chemicals / Solvents, Diesel, Kerosene, Thinners, Acetone, Benzene, Naptha, Urea, DEF, Adblue, Light oil (up to SAE 40) etc.

DO NOT USE WITH
Heavy oils

FEATURES

FLOW RATE	STAINLESS STEEL
UP TO 25 OZ. (750 ML) / STROKE	

SPECIFICATIONS

PUMP TYPE	Vertical Lift
MAX. VISCOSITY	SAE 40
ADAPTER TYPE	2"
MAX. TEMPERATURE	60° C (140°F)



An extra set of spare seals and flow control tubes included with each pump

WARNING
WARNING: This product contains chemicals, including lead, known to the State of California to cause cancer, birth defects or other reproductive harm. *Wash hands after handling.*

PERSONAL SAFETY

1. Wear safety glasses at all times when working with this pump.
2. Wear a face shield, proper apparel and suitable respiratory equipment when pumping hazardous chemicals.
3. Keep work area clean, uncluttered and properly lit. Replace all unused tools and equipment

WARNING

Failure to follow all general safety information can result in a fatality, personal injury and/or property damage.

ASSEMBLY AND OPERATION

1. Take the pump body from the box and adjust the height of bung assembly (16) to be threaded into the drum
2. Screw the outlet spout (12) onto the pump head (1) along with the teflon seal placed in the kit (17)
3. Start operating the T-Handle (7) by moving it up and down. Within a maximum of 4 strokes, pump will start dispensing media. The higher the lift of the handle, the greater the discharge will be per stroke
4. Pump comes with 5 flow control tubes in the kit (17) which can be inserted between spring (6) & nut (3) according to the flow requirement

Note: The flow control tubes will restrict the flow and each tube will approximately reduce the flow rate by 100 ml (3.4 oz.). Combination of tubes can be used together, but the discharge will decrease.

MAINTENANCE

1. The pump has been designed and built to require a minimal amount of maintenance.
2. All maintenance must be performed by qualified personnel.

PRIMING

When using the pump for the first time or after a long interval of time, the pump may need priming. Priming is done by stroking the handle 4-5 times to re-prime it.

Note: If the pump is not used for an extended period of time, it may lose its prime and need re-priming.

CAUTION

1. Never let any body part come in front of, or in contact with the pump outlet
2. In case of accident, immediately seek medical attention. Do not try to treat the injury yourself
3. Use only genuine factory parts for repair
4. Keep all sources of fire away from the pump

STEPS ON HOW TO REPLACE DAMAGED SEAL

1. Hold the rod (5) in a vice and rotate the T-Handle (7) counter-clockwise to disassemble it from rod.



2. Now, remove the spring (6) from the rod (5)



3. Unscrew the nut (3) from the rod



4. Pull the seal (4) out



5. Now take the seal (4) to be replaced from the kit and insert it over the rod (5)



6. Screw the nut (3) and place the spring (6) & assemble the T-Handle (7) by turning it clockwise



EXPLODED VIEW

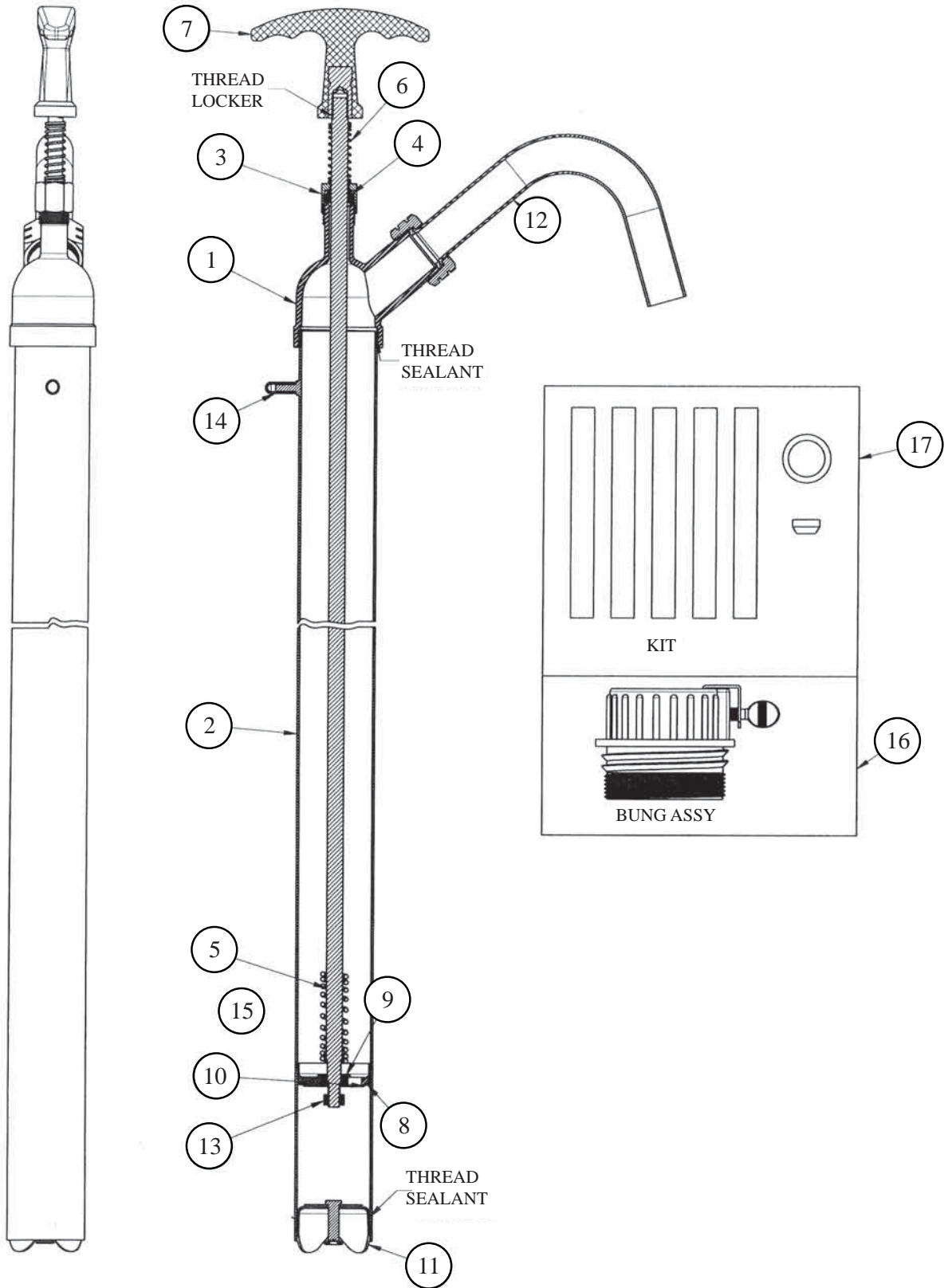



* No replacement parts are available for this unit, descriptions and quantities are for reference only

PARTS LIST

REF NO.	PARTS DESCRIPTION	QTY.
1	Head	1
2	Barrel	1
3	Nut	1
4	Seal	1
5	Rod	1
6	Spring	1
7	T-Handle	1
8	Plunger	1
9	Steel Washer	1
10	Washer	1
11	Sub. Assembly of Follower Cap	1
12	Bend Pipe Assembly	1
13	Lock Nut	1
14	Protecting Cap	1
15	Spring	1
16	Bung Assembly	1
17	Kit	1

TROUBLESHOOTING

PROBLEM	CAUSE	SOLUTION
Pump does not dispense fluid or does not prime.	1. Pump is drawing in air, instead of fluid.	1. Tighten suction tube with the pump inlet and apply the seals for leaks. Tighten fasteners and replace seals.
	2. Suction tube inlet is clogged	2. Clean suction tube inlet
Handle difficult or impossible to move.	1. Pump has not been used for a long time	1. Inspect for deposits on components. Clean or replace parts. Flush pump with the media being used if pump has not been in use for a long period of time.