



ATD-3425

Vacuum Pump

As a specialized enterprise in making vacuum pumps, we have devoted ourselves to satisfy our customers' need for high quality products. We adopt the latest designs and technology to make sure that our products not only use less energy, produce less noise and last longer but also to ensure that they have the best design for the environment and for reducing pumped gas pollution. Excellent design and production will bring you more convenience.

1. Pump Use

ATD vacuum pumps are designed to obtain vacuum by pumping gas from sealed containers. They are suitable for use with R12, R22 and R134a air conditioning systems, as well as medical appliances, printing machinery and vacuum packing.

They can be continuously used at 5°C to 40°C

2. Features

Oil Anti-flowback Design

The gas inlet is specially designed to prevent the oil from flowing back, preventing the container being pumped as well as the hoses from becoming polluted.

Environmental Design

The tank has separating devices at the exhaust port to prevent oil-spraying and to reduce pollution.

Aluminum Alloy Casing

The ATD vacuum pump is manufactured with an aluminum alloy casing. Because aluminum has good heat dissipation qualities, it will help to keep the pump running more efficiently for a longer period of time.

Overall Design

The electric machinery and the pump are designed to make the product compact and lighter.



Vacuum Pump

Easy to start, Faster to pump

The starter design makes the ATD vacuum pump easy to start even in lower temperatures. This feature allows higher efficiency and faster pumping.

Low Noise and Vibration

An elastomeric coupling insert between the motor and module results in extremely quiet and smooth operation.

3. Product Illustration

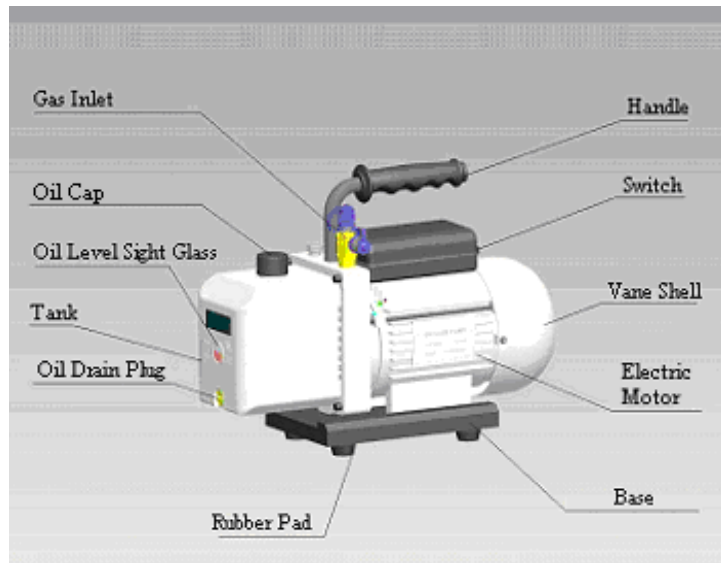



Vacuum Pump

4. User's Manual

- Examine the oil-level before using to make sure the oil-level is not lower than the oil-level line in the sight glass. **DO NOT RUN PUMP WITH LOW OIL LEVELS.** Add oil to bring it up to the oil level line. This pump uses high-speed vacuum oil HFVM200 or equivalent.
- Connect the container to be pumped to the gas inlet. The hose should be short, sealed and free of dust, dirt and heavy condensation. Check for leaks before operating pump.
- Take off the exhaust cap, plug in the power supply and turn the switch to the on position.
- Unplug the vacuum pump, remove the connecting hoses and cover the exhaust cap and oil plug after using.

5. Cautions

- Don't pump flammable, explosive or poisonous gases.
- Don't pump gas that can corrode metals and exert chemical charges.
- Don't pump gas containing any dust or moisture.
- The temperature of the pumped gas shouldn't be over 80°C and the room temperature should be around 5°C to 40°C
- Don't use vacuum pump as a compression pump.
- Pump cannot be run without oil
- The operating voltage is between 110V to 115V, 60Hz. You must use a grounded

outlet.

·When unplugging the pump, pull the plug. Don't unplug unit by pulling on the wire.

·Keep electrical cord free from all shop equipment, and do not let pump hang by power cord

·Don't use damaged plug or outlet.

·Don't plug or pull out the plug with wet hands.

·Don't plug unit in, unplug unit or use switch if there are any flammable or explosive gases present.

·Always Unplug unit before disassembling.

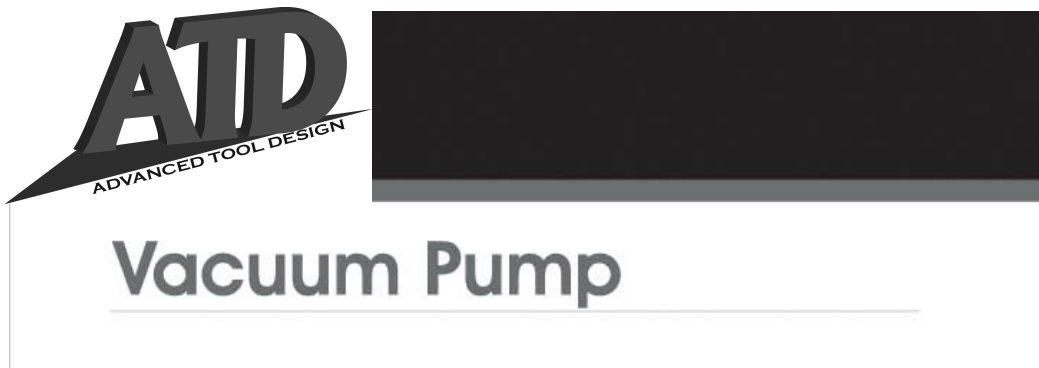

6. Installation

·When in use, the pump should be horizontal and should be positioned where it is dry, ventilated and free of dust and other contaminants.

·In order to ensure proper air flow, you must maintain a clearance around the pump of at least 5 cm (2 inches).

·To permanently mount the vacuum pump, remove the rubber pads from the bottom of the base, and use the existing threaded holes to mount unit. Connect with M4x12 screw and M4 nut. When permanently mounting this pump, be sure to maintain proper clearances around the unit, especially at the air intake in the end of the vane shell.

·If a special electromagnetic valve is needed, it can be installed on the gas inlet.

7. Troubleshooting

Problem	Possible Cause	Correction
Low Degree of Vacuum	<ol style="list-style-type: none"> 1. Lack of oil 2. Oil is not clean 3. The oil inlet is blocked 4. The hoses or gas inlet are clogged 5. The pump is not suitable for your application 	<ol style="list-style-type: none"> 1. Add oil to above the oil level line 2. Change the oil 3. Clean the oil inlet or clean the filter 4. Check the connecting pipes 5. Get suitable pump for your application
Oil Leaks	<ol style="list-style-type: none"> 1. The oil seal is damaged 2. The housing gasket is loose or worn out 	<ol style="list-style-type: none"> 1. Change oil seal 2. Change the housing gasket
Oil Spray	<ol style="list-style-type: none"> 1. Too much oil 2. The pressure at the gas inlet is too high or it has pumped too much 	<ol style="list-style-type: none"> 1. Oil to the oil-level line 2. Change to a bigger pump
Starting Difficulty	<ol style="list-style-type: none"> 1. The oil temperature is too low 2. Electrical malfunction 3. Foreign matter is in the pump 	<ol style="list-style-type: none"> 1. Start the pump several times to try to heat the oil 2. Check and have it fixed 3. Check and remove it



Vacuum Pump

8. Maintenance

·Keep the pump clean and prevent foreign matter from entering.

·Keep the oil filled to the full level. **Don't let pump run without oil.**

·Keep the oil clean. If the oil becomes dirty, muddy, or water or other volatile substance gets in, it will affect the performance of the pump and the oil should be replaced. Before replacing the oil, start the pump and have it run for about 30 minutes to make the oil thin. Stop the pump and drain the oil from the oil drain plug. At this time, open the gas inlet to release any pressure inside the pump. This will allow the oil to drain more freely. After making sure the pump is clean, put the drain plug back in

and then fill the pump oil to the oil-level.

·To store the pump when not in use for long periods of time, cover the oil cap and exhaust cap and store it in a dry place.

·**Repair of pump should only be done by experienced repair facilities.**

9. Technical Specifications

Model: ATD-3425

Model Power Supply: 110V 60HZ

Free Air Displacement: 5 CFM

Number of Stages: 1 Stage

Ultimate Vacuum: 180 Micron

Rotating Speed: 1720 r/Min

Motor: 1/3 HP

Weight: 14 KGS



ATD-3425

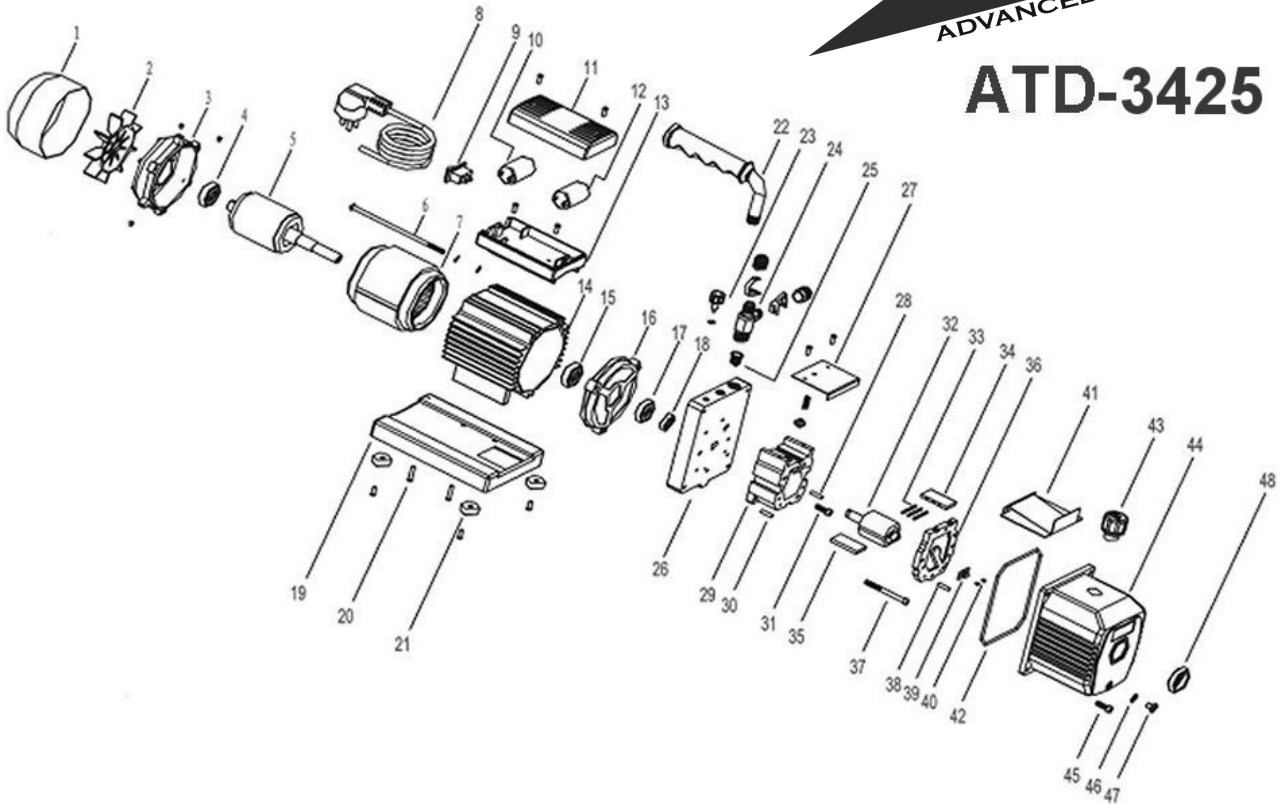

ORDERING PART#	ITEM#	PART DESCRIPTION
PRT3425-01	1	FAN COVER
PRT3425-02	2	FAN
PRT3425-03	3	MOTOR COVER
PRT3425-04	4	BEARING
PRT3425-05	5	MOTOR ROTOR
PRT3425-06	6	LONG SCREW
PRT3425-07	7	MOTOR STATOR
PRT3425-08	8	POWER CORD
PRT3425-09	9	SWITCH
PRT3425-10	10	CAPACITOR
PRT3425-11	11	CAPACITOR COVER
PRT3425-12	12	CAPACITOR
PRT3425-13	13	JUNCTION BOX
PRT3425-14	14	MOTOR HULL
PRT3425-15	15	BEARING
PRT3425-16	16	MOTOR COVER
PRT3425-17	17	BEARING
PRT3425-18	18	OIL SEAL
PRT3425-19	19	BASE
PRT3425-20	20	SCREW
PRT3425-21	21	RUBBER PAD
PRT3425-22	22	HANDLE
PRT3425-23	23	ADJUSTER
PRT3425-24	24	INLET PORT

ORDERING PART#	ITEM#	PART DESCRIPTION
PRT3425-25	25	FILTER
PRT3425-26	26	TRESTLE
PRT3425-27	27	DRAIN TAP
PRT3425-28	28	PIN
PRT3425-29	29	PUMP STATOR
PRT3425-30	30	PIN
PRT3425-31	31	SCREW
PRT3425-32	32	PUMP ROTOR
PRT3425-33	33	SPRING
PRT3425-34	34	ROTARY VANE
PRT3425-35	35	ROTARY VANE
PRT3425-36	36	PUMP COVER
PRT3425-37	37	SCREW
PRT3425-38	38	PIN
PRT3425-39	39	FILTER
PRT3425-40	40	SCREW
PRT3425-41	41	OIL SPLASH GUARD
PRT3425-42	42	HOUSING GASKET
PRT3425-43	43	EXHAUST FITTING
PRT3425-44	44	DIE CAST ALUMINUM HOUSING
PRT3425-45	45	SCREW
PRT3425-46	46	RUBBER GASKET
PRT3425-47	47	OIL DRAIN PLUG
PRT3425-48	48	SIGHT GLASS