

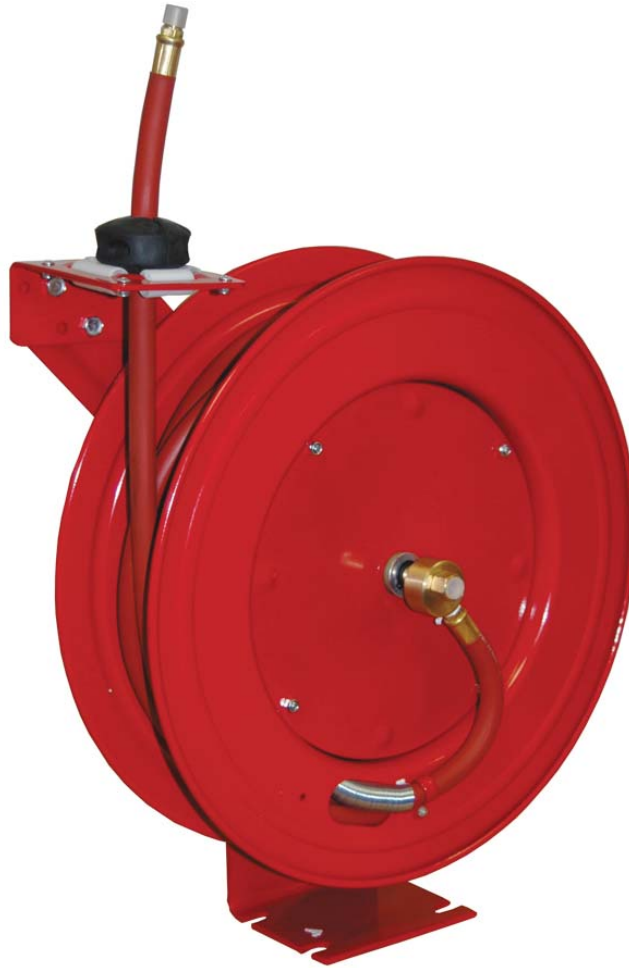

ATD-31166
3/8" x 50' Retractable Air Hose Reel
Owner's Manual



FEATURES

- Heavy-gauge, all-steel reel assembly
- 8-position ratchet mechanism locks reel at desired hose length
- 5-position adjustable roller outlet arm and slotted mounting bolt holes allow easy reel mounting to ceiling, wall, floors, workbenches, vehicles, etc.

SPECIFICATIONS

- Maximum Pressure: 300 psi
- Hose: 3/8" x 50 ft.
- Max Air Flow: 25 CFM
- Inlet Air Connection 1/4" NPT(F) swivel
- Hose Connections 1/4" NPT(M)

Read and understand entire manual before assembling or using hose reel

Failure to follow instructions or warnings could result in personal injury and/or property damage.

SAFETY

DO NOT EXCEED 300 PSI incoming air pressure (from compressor)

Wear impact-resistant eye protection that meets ANSI Spec. Z87.1 in work area at all times.

Do not release hose when rewinding. Hold hose end and allow hose to rewind slowly.

Never allow children to use hose reel. Keep children clear of work area at all times.

WARNING

Do not over tighten reel. This may permanently damage the spring in the winding mechanism. Ideally, the reel should be adjusted to wind up only as far as the desired height needed to reach the hose stop.

Exercise care when handling the hose reel during normal operation. This hose reel has a rotating spool powered by springs under tension.

Mounting hardware and fasteners should be installed to maintain tightness under vibration and checked periodically to ensure tightness.

Overhead installation mountings should be such that the reel is not supported by bolts in tension. A safety chain or cable is strongly recommended to minimize damage and/or possible injury in the event of mounting failure.

INSTALLING HOSE REEL

Note: Due to the infinite ways one would mount this reel, the mounting hardware is not included and must be purchased separately. Decide first where reel will be mounted before purchasing hardware. Different mounting positions require different types of hardware.

Reel can be mounted on the floor, ceiling, or wall. When choosing a location, remember that you can only mount reel to a load-bearing structural member capable of supporting combined weight of reel, hose, and forces caused by pulling or maneuvering hose. Generally, mounting reel near your air compressor is best since you can connect the two with a shorter, less expensive length of hose. Also, air compressor controls will be nearby for convenient adjusting.

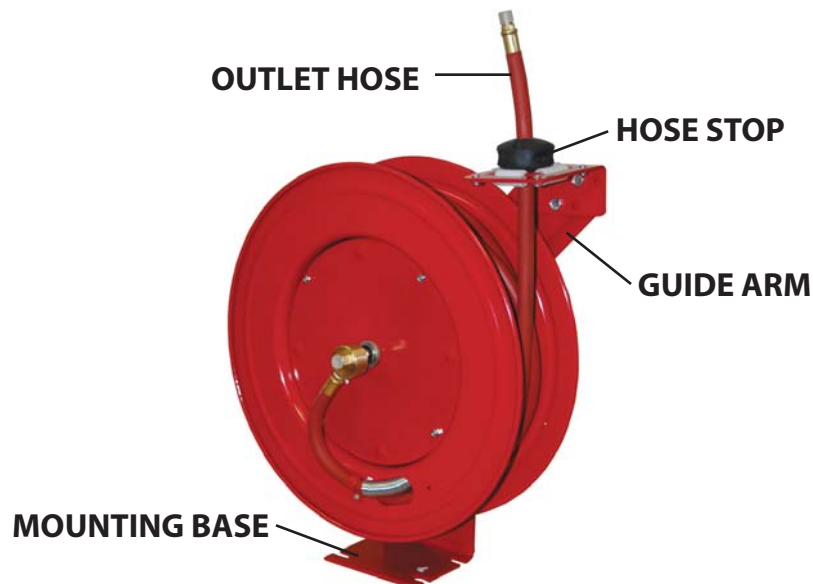

Once you have located a mounting spot, consult the “**Typical Mounting Positions**” chart below and choose the diagram that most closely matches your mounting position. If necessary, adjust guide arm position to match diagram.

TYPICAL MOUNTING POSITIONS

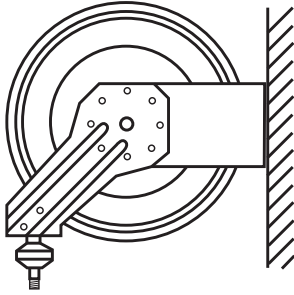

WALL

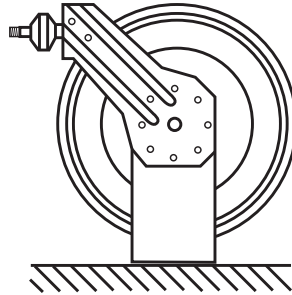

FLOOR

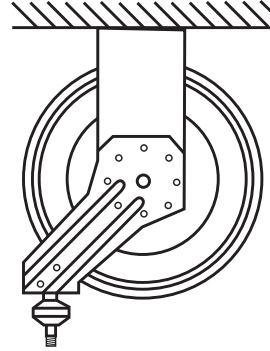

CEILING

ADJUSTING THE GUIDE ARM

- Pull out 3 feet of hose and allow reel to lock in position.
- Remove the four bolts connecting guide arm to mounting base.
- Rotate guide arm in 90° increments to desired position total number of positions is five (5).
- Replace four bolts and tighten.

Continue by choosing proper mounting hardware. See illustration on following page for dimensions. Use washers on mounting bolts to help bear weight of reel (bolts and washers are not included). After reel is secured in position, attach air hose coming from compressor. Wrap threads of male connector on incoming air hose with Teflon tape (included) or thread sealant and connect to air inlet valve on side of hose reel. Connect other end of incoming air hose to air compressor. Apply Teflon tape to threads on hose before attaching air tools.

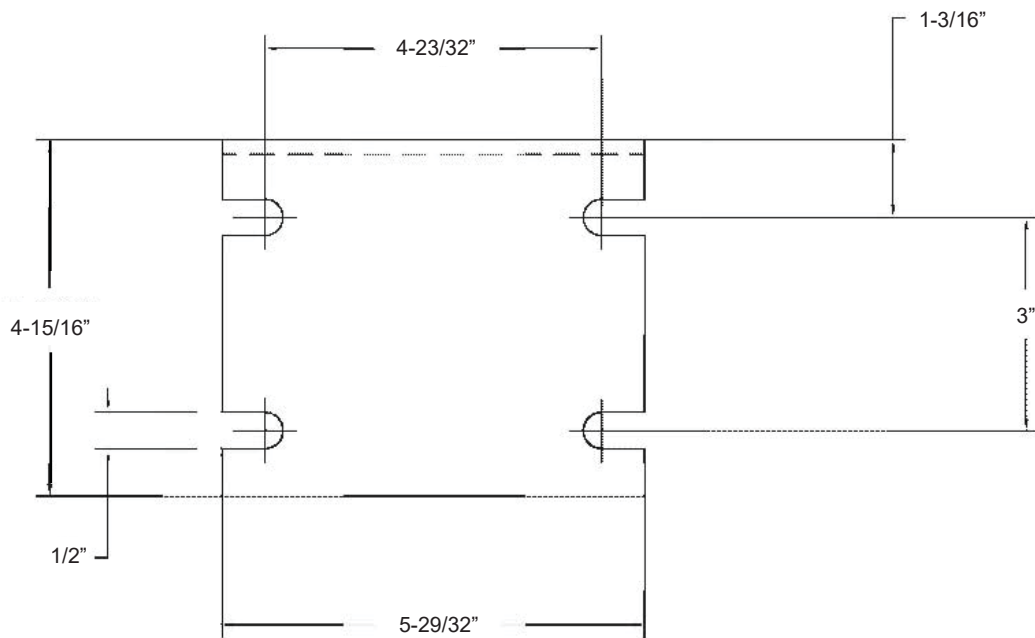
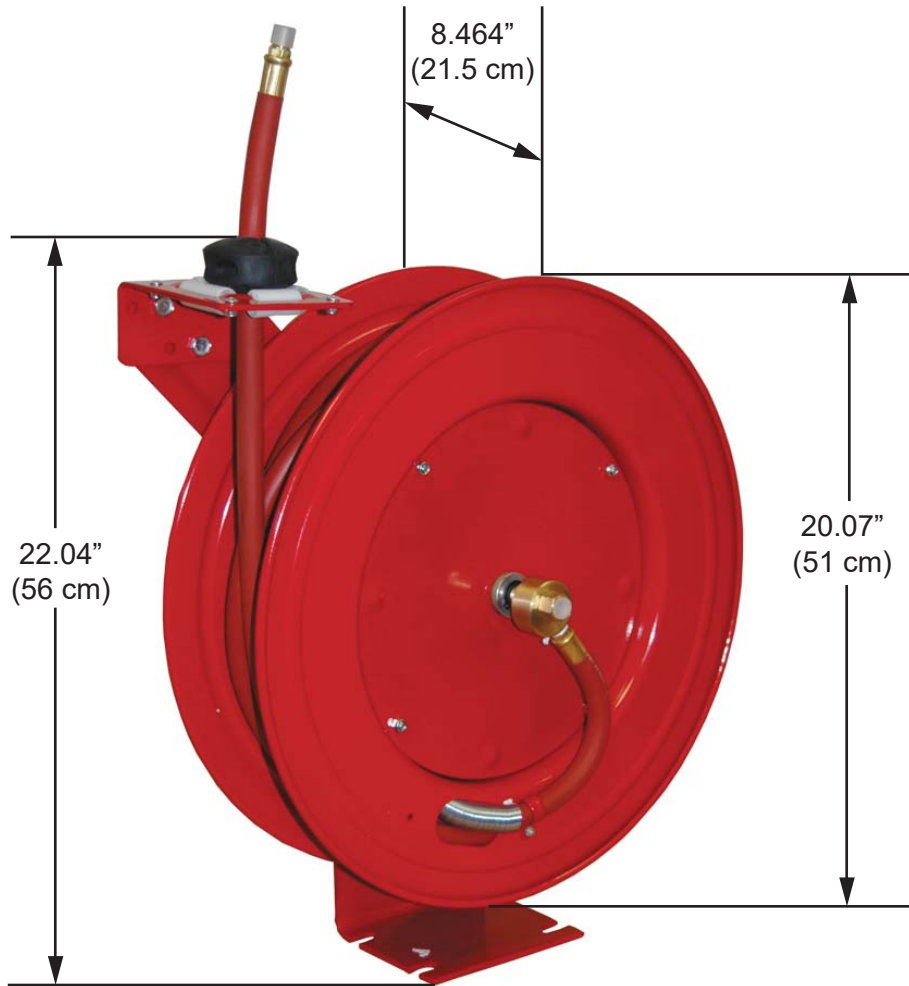

ADJUSTING THE HOSE BALL STOP

The hose ball stop determines the length of hose that remains outside of reel. To adjust, pull hose out past desired position of hose ball stop and latch reel. Loosen both screws and move ball stop to proper position. Tighten screws.

Operating Hose Reel

1. Slowly pull hose from reel to desired length. A ratcheting mechanism inside reel makes a short series of clicking sounds every half revolution of reel.
2. **To lock** reel in position, listen for clicking sounds as hose is slowly pulled from reel. When reel clicks, stop pulling hose. Decrease tension on hose and reel should lock in position.
3. **To retract** hose onto reel, slowly pull out hose until series of clicking sounds stops (1/8 revolution).
DO NOT LET GO OF HOSE!
4. Allow hose to retract slowly until hose ball stop rests against the hose guide.
5. Periodically check the hose for excessive wear and hose connections for air leaks.

ADJUSTING RECOIL TENSION

1. Disconnect incoming air supply.
2. Pull out about 2 feet of hose and latch the reel.
3. Remove hose ball stop
4. **While firmly holding onto edge of reel drum**, unlatch reel and carefully allow drum to slowly rewind, drawing hose end back through guide arm roller assembly and onto reel. Latch reel in position.
5. **To Increase Tension:** Unlatch reel and turn clockwise (as viewed from air inlet side).
To Decrease Tension: Unlatch and allow reel to rotate slowly counterclockwise (as viewed from air inlet side).
6. Once desired spring tension is reached, latch reel in position. Feed hose end through roller assembly in guide arm and reattach hose ball stop.
7. Connect incoming air supply.

REPLACING HOSE

1. Secure and stabilize reel. In most cases, hose can be replaced with reel still mounted.
2. Disconnect incoming air supply.
3. Pull out entire length of hose and lock reel. **Make sure reel is securely locked in place.**
4. Unscrew hose clamps that secure hose to drum. Disconnect inlet-end of hose from air inlet valve.
5. Pull inlet-end of hose through slot in drum and guide rollers, removing old hose completely.
6. Remove spring hose guard, hose clamp and hose ball stop from old hose. Fit these parts on new hose in identical positions.
7. Feed inlet-end of hose through guide rollers and slot in drum.
8. Apply Teflon sealant tape or thread sealant to hose connector and connect to air inlet valve.
9. Attach hose clamp to drum. Rewind hose onto reel using normal operation.

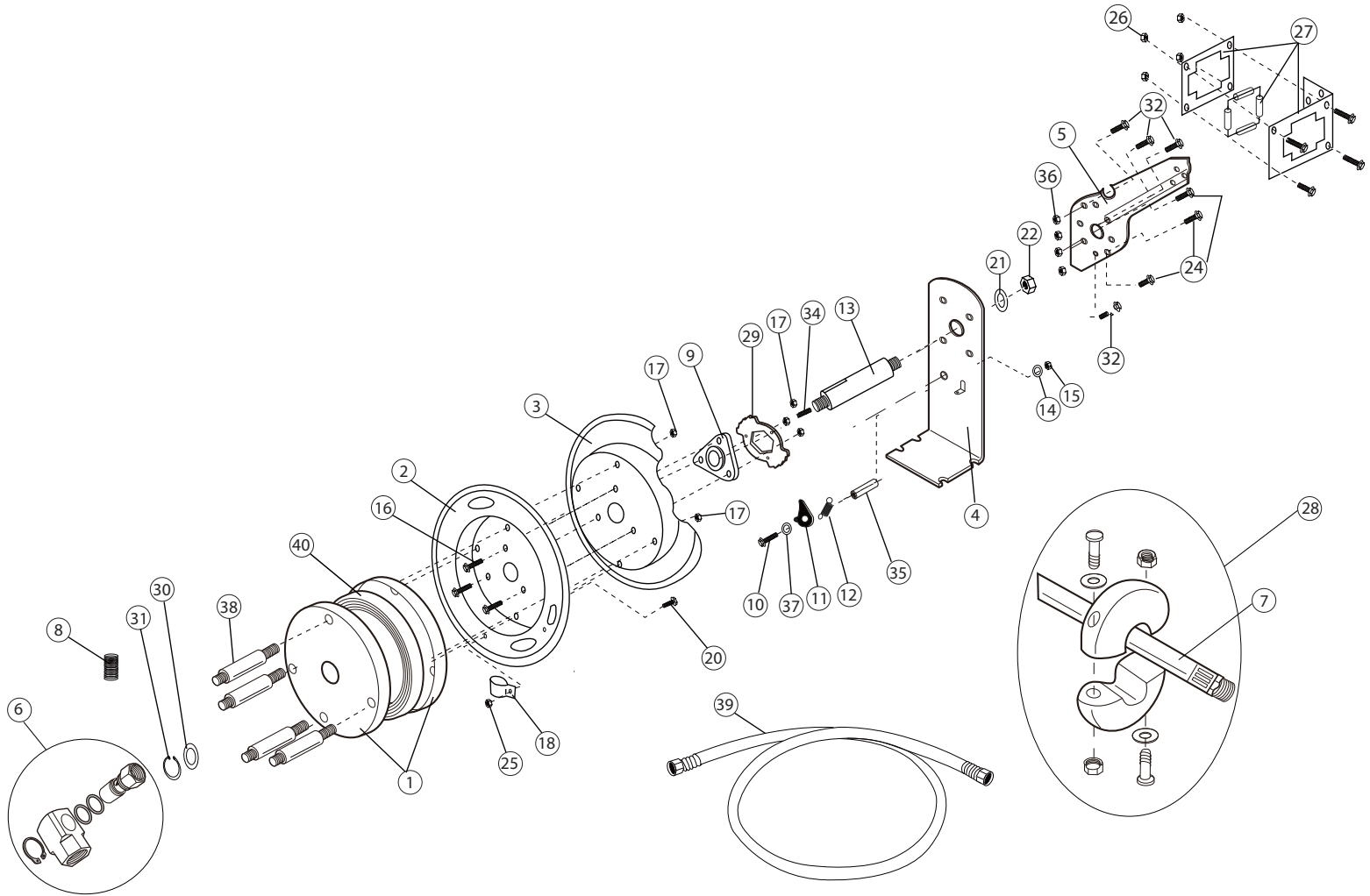

ITEM#	ORDERING PART#	PART DESCRIPTION
1	PRT31166-01	SPRING CANISTER ONLY
2	PRT31166-02	DRUM (AIR INLETSIDE)
3	PRT31166-03	DRUM (MOUNTING BRACKET SIDE)
4	PRT31166-04	MOUNTING BRACKET
5	PRT31166-05	GUIDE ARM
6	PRT31166-06	AIR INLET VALVE BODY & SWIVEL COLLAR WITH O-RINGS
7	PRT31166-07	3/8" HOSE
8	PRT31166-08	SPRING HOSE GUARD
9	PRT31166-09	HUB BEARING ASSEMBLY
10	PRT31166-11-29	LOCKING CAM, SPRING, LOCKING GEAR KIT*
11	PRT31166-11-29	LOCKING CAM, SPRING, LOCKING GEAR KIT*
12	PRT31166-11-29	LOCKING CAM, SPRING, LOCKING GEAR KIT*
13	PRT31166-13	AXLE
14	PRT31166-14	LOCK WASHER
15	PRT31166-15	NUT
16	PRT31166-16	BOLT
17	PRT31166-17	LOCK NUT
18	PRT31166-18	CLAMP
20	PRT31166-20	BOLT

ITEM#	ORDERING PART#	PART DESCRIPTION
21	PRT31166-21	WASHER
22	PRT31166-22	NUT
24	PRT31166-24	BOLT
25	PRT31166-25	NUT
26	PRT31166-26	LOCK NUT
27	PRT31166-27	ROLLER GUIDE BRACKET ASSEMBLY
28	PRT31166-28	HOSE STOPPER ASSEMBLY
29	PRT31166-11-29	LOCKING CAM, SPRING, LOCKING GEAR KIT*
30	PRT31166-30	SPACING WASHER
31	PRT31166-31	RETAINING RING
32	PRT31166-32	BOLT
34	PRT31166-34	SET SCREW
35	PRT31166-35	SPACING WASHER
36	PRT31166-36	NUT
37	PRT31166-37	SPACING WASHER
38	PRT31166-38	PIN
39	PRT31166-39	3/8" LEAD HOSE
40	PRT31166-40	SPRING

*PRT31166-11-29 includes item numbers 10, 11, 12 & 29



WARRANTY

1 YEAR LIMITED WARRANTY

THIS WARRANTY AND CONFIRMED RECEIPT(S) SHOULD BE RETAINED BY THE CUSTOMER AT ALL TIMES

PURCHASED FROM: _____

DATE PURCHASED: _____

INVOICE/RECEIPT NUMBER: _____

Your ATD-31166 is warranted for a period of 12 months from the original purchase date.

For a period of one (1) year from your purchase date, ATD Tools Inc. will repair or replace (at its option) without charge, your ATD product if it was purchased new and the product has failed due to a defect in material or workmanship which you experienced during normal use of the product. This limited warranty is your exclusive remedy.

To access the benefits of this warranty, contact your supplier, or point of sale directly. You may be advised to return the product under warranty, freight prepaid, to your supplier for warranty determination.

If this ATD product is altered, abused, misused, modified, or undergoes service by an unauthorized technician, your warranty will be void. We are not responsible for damage to ornamental designs you place on this ATD product and such ornamentation should not cover any warnings or instructions or they may void the warranty. This warranty does not cover scratches, superficial dents, and other abrasions to the paint finish that occur under normal use. It also does not cover normal wear items such as but not limited to brushes, batteries, drill bits, drill chucks, pads or blades.

Subject to the law in your state:

- (1) Your sole and exclusive remedy is repair or replacement of the defective product as described above.
- (2) ATD is not liable for any incidental damages, including but not limited to, lost profits and unforeseeable consequences.
- (3) The repair and replacement of this product under the express limited warranty described above is your exclusive remedy and is provided in lieu of all other warranties, express or implied. All other warranties, including implied warranties and warranties of merchantability or fitness for a particular purpose are disclaimed and, if disclaimer is prohibited, these warranties are limited to one year from your date of purchase of this product.

Some states' laws do not allow limited durations on certain implied warranties and some states' laws do not allow limitations on incidental or consequential damages. You should consult the law in your state to determine how your rights may vary.

[Affix receipt or invoice here for safe keeping]