

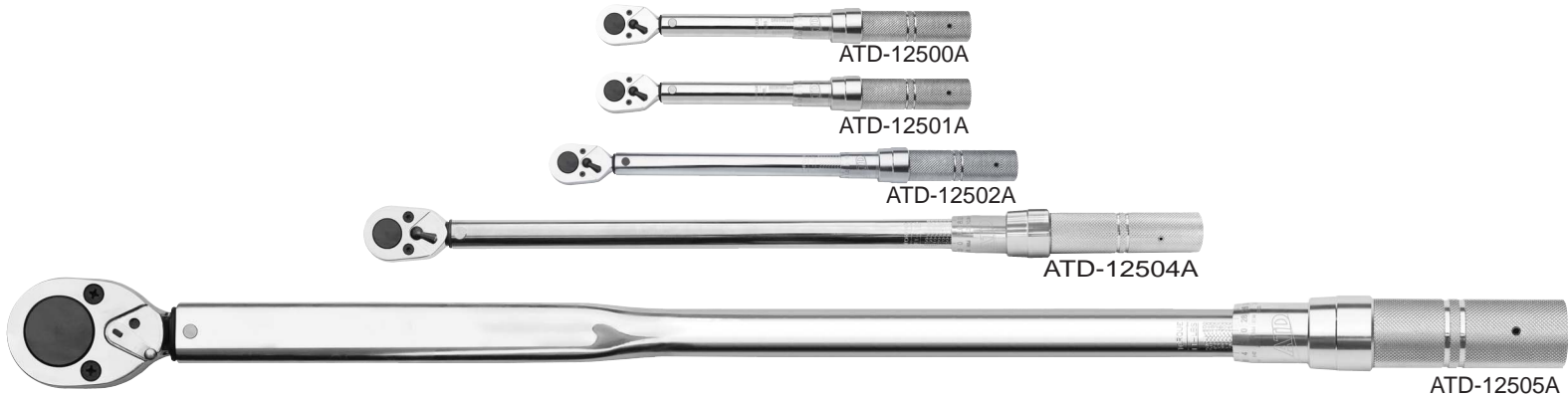

ATD-12500A, ATD-12501A, ATD-12502A ATD-12504A and ATD-12505A Micrometer Torque Wrench Owner's Manual



Features:

- Knurled handle for non-slip grip
- Easy-to-read stamped scale on beam & thimble collar
- Positive lock with spring loaded pull down lock ring
- Fast, accurate and easy to set
- Teardrop ratchet head
- Meets ISO 6789 specifications
- Calibrated on test equipment complying with ASME B107.300-2010 accuracy requirements
- Comes in blow molded storage case with instructions and calibration certificate

Specifications:

Model	Drive	Length	Primary Scale		Secondary Scale
			Torque Range	Increment	Torque Range
ATD-12500A	1/4"	11.75"	40-200 in.-lbs.	10	5.1-23.2 Nm
ATD-12501A	3/8"	11.75"	50-250 in.-lbs.	10	6.2-28.8 Nm
ATD-12502A	3/8"	16.5"	20-100 ft.-lbs.	5	30.5-138.9 Nm
ATD-12504A	1/2"	25.5"	50-250 ft.-lbs.	10	74.6-345.7 Nm
ATD-12505A	3/4"	41.5"	120-600 ft.-lbs.	30	183-833.7 Nm

Operating Instructions

Please read and save these instructions. Read through this owner's manual carefully before using product. Protect yourself and others by observing all safety information, warnings, and cautions. Failure to comply with instructions could result in personal injury and/or damage to product or property. Please retain instructions for future reference.

Description

ATD micrometer torque wrench is a precision instrument designed to accurately measure torque. Other uses should be avoided. It should never be used to break loose stubborn fasteners.

The self-contained torque limiting mechanism employs an exclusive, patented design that minimizes friction, and is rugged and dependable. The precision made part are sealed so dirt or liquids cannot easily affect the built-in accuracy of the mechanism. The wrench is not affected by extreme changes of temperature.

Unpacking

After unpacking unit, make sure all parts are present. If any part is missing or damaged, do not attempt to use the product. Contact your distributor. Shipping damage claim must be filed with carrier.

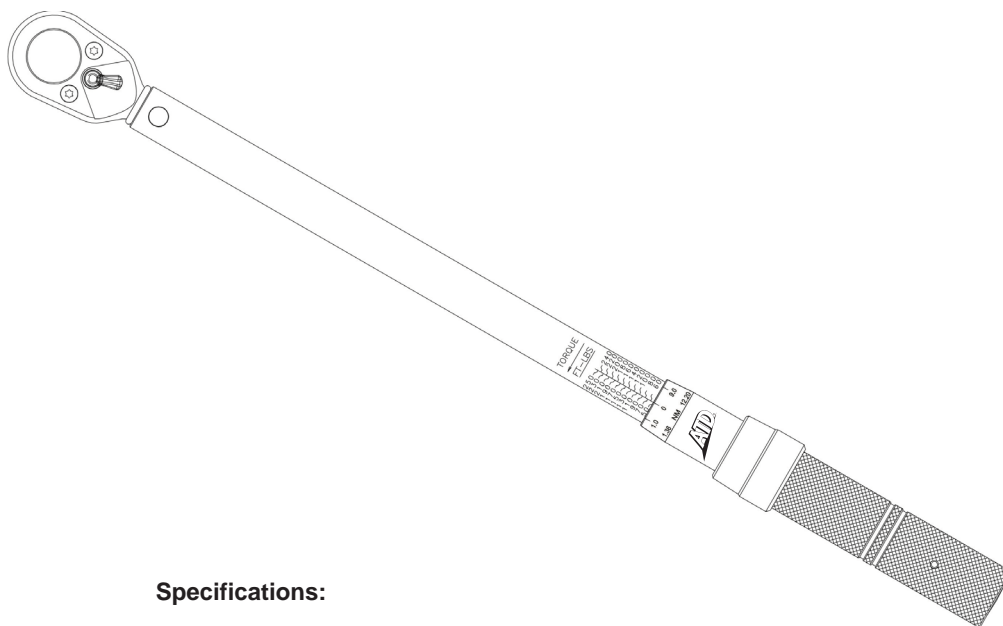

Specifications:

Model	Drive	Length	Primary Scale		Secondary Scale
			Torque Range	Increment	Torque Range
ATD-12500A	1/4"	11.75"	40-200 in.-lbs.	10	5.1-23.2 Nm
ATD-12501A	3/8"	11.75"	50-250 in.-lbs.	10	6.2-28.8 Nm
ATD-12502A	3/8"	16.5"	20-100 ft.-lbs.	5	30.5-138.9 Nm
ATD-12504A	1/2"	25.5"	50-250 ft.-lbs.	10	74.6-345.7 Nm
ATD-12505A	3/4"	41.5"	120-600 ft.-lbs.	30	183-833.7 Nm

General Safety Information

Your torque wrench was calibrated and tested before leaving the factory and is guaranteed to meet or exceed ASME B107.14 standard.

Because your torque wrench is a precision measuring instrument, it should be serviced only by authorized service centers.

CAUTION Do not continue pulling on the wrench after pre-set torque has been reached. Pressure must be taken off the handle and the wrench allowed to automatically reset itself.

CAUTION Ratchet mechanism may slip or break if dirty, mismatched or if worn parts are used. Ratchets that slip or break can cause injury.

Operation

1. To unlock the handle, hold the body tube and pull the locking ring (A) back, allowing the handle (B) to turn clockwise or counterclockwise.
2. Set the desired torque by turning the handle. For example, 85 ft-lbs.
 - a. Pull the locking ring to adjust the torque.
 - b. Turn the handle until the zero graduation on minor scale lines up with the vertical line and is even with 80 ft-lb graduation.
 - c. Turn the handle clockwise and set the minor scale to "five (5)" on the vertical line. Now the torque is set at 85 ft-lbs.

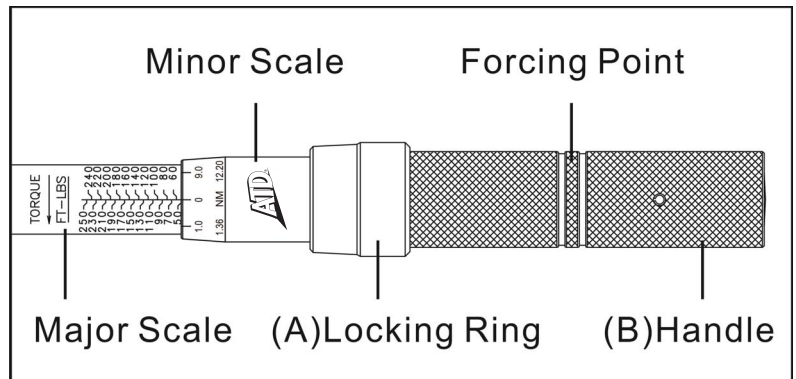

3. Release the locking ring to lock the handle.
4. Install the proper socket or attachment to the square drive and apply to the object being torqued. Applying a steady pull to the center of handle, and stop pulling when a "Click" sound is heard. The release is distinct and unmistakable. It can be felt as well as heard. When pressure is removed from the handle, the torque wrench will automatically reset itself.

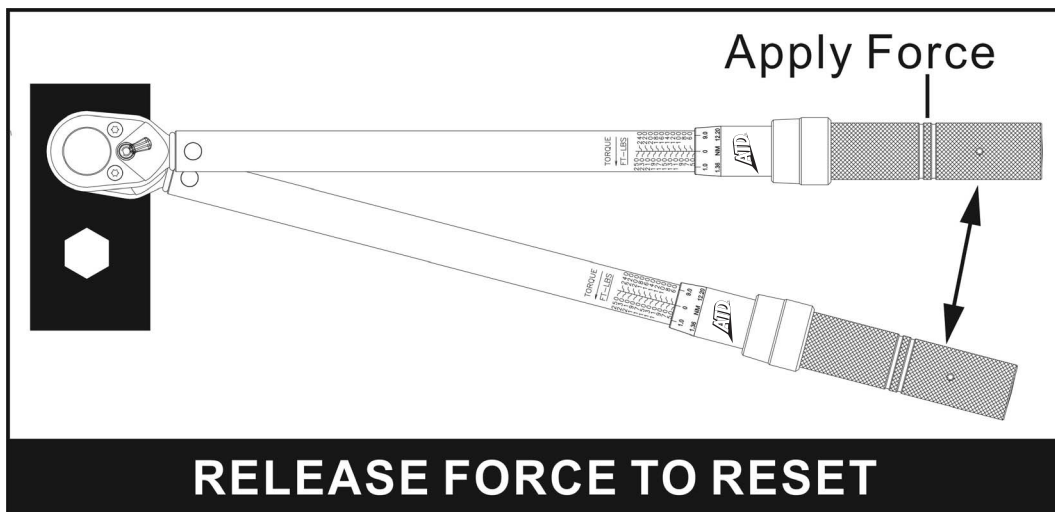

Use of Extensions and Adapters

When using an extension or adapter (increasing the effective length of the torque wrench), the output torque value will change. To calculate the new torque output of the torque wrench, use the following:

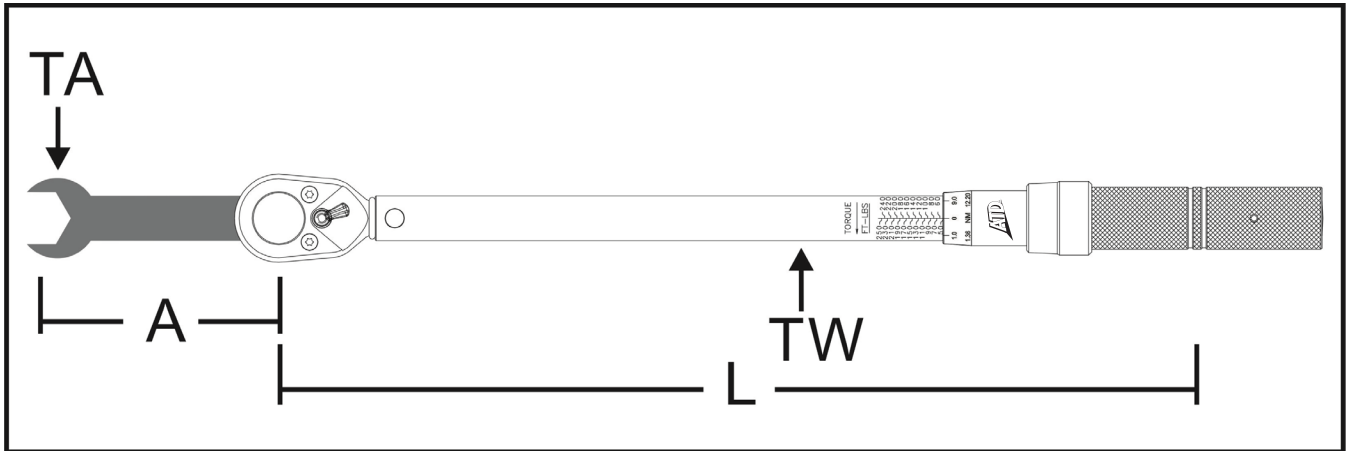

$$TW = \frac{TA \times L}{L=A}$$

TW = Torque wrench scale reading
 TA = Torque exerted at end of adapter
 L = Distance between square drive and hand position
 A = Length of adapter or extension

NOTE: A number of variables including the length of the adapter or extension, length of the torque wrench, and variations in hand position on the torque wrench, will affect the accuracy of the above calculation.

Conversion Table					
FROM UNIT	TO UNIT	MULTIPLY BY	FROM UNIT	TO UNIT	MULTIPLY BY
in.-oz.	in.-lb	0.0625	dNm	Nm	0.1000
in.-lb.	in.-oz.	16.0000	Nm	cNm	100.0000
in.-lb.	ft.-lb.	0.0834	Nm	Kgf.cm	10.2000
in.-lb.	Kgf.cm	1.1519	Nm	Kgf.m	0.1020
in.-lb.	mkg	0.0116	Nm	in.-lb.	8.8500
in.-lb.	dNm	0.1130	Nm	ft.-lb.	0.7376
in.-lb.	Nm	1.1300	Kgf.cm	in.-lb.	0.8681
ft.-lb.	in.-lb	12.0000	Kgf.cm	Nm	0.0981
ft.-lb.	Kgf.m	0.1382	Kgf.m	in.-lb.	86.8100
ft.-lb.	Nm	1.3560	Kgf.m	ft.-lb.	7.2360
dNm	in.-lb	0.8850	Kgf.m	Nm	9.8070

Maintenance

ROUTINE MAINTENANCE

1. The internal mechanism of torque wrench is lubricated during assembly. Do not attempt to lubricate the wrench's internal mechanism.
2. Clean wrench by wiping with clean cloth. Do not immerse wrench in liquids when cleaning.
3. Store torque wrench in protective case at its lowest torque setting. Do not force handle below its lowest setting.
4. Periodic re-calibration is necessary to maintain accuracy, once a year or after 5,000 times usage. Calibration must be done by an authorized service center.

MAJOR MAINTENANCE, SERVICE AND PART REPLACEMENT

1. Disassembly the torque wrench is not suggested. Please contact the service center if you have any questions.
2. Head repair kits are available through the service center.



THIS WARRANTY AND CONFIRMED RECEIPT(S) SHOULD BE *RETAINED BY THE CUSTOMER* AT ALL TIMES

Until one year from the date of purchase, we will repair any defect in material or workmanship free of charge. Improper use of these products, including but not limited to the application of excessive force, will affect performance and may result in injury. The warranty does not apply to wrenches which do not function properly or within specified accuracy because of wear, improper or unreasonable use, damage not resulting from defect or malfunction, or which have been altered.

Calibration is warranted for 90 days.

This warranty gives you specific legal rights, and you may also have other rights which vary from state to state. For repair or calibration send wrench, postage prepaid, to:

**ANGLE REPAIR SERVICES, INC.
175 ANGLE DRIVE
BECKLEY, WEST VIRGINIA 25801
304-253-5729**