

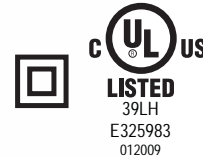

# ATD-10522 1/2" DRIVE ELECTRIC IMPACT WRENCH OWNER'S MANUAL



## Features:

- Delivers 240 ft. -lbs. of torque for high-demand projects and heavy-duty fastening applications
- Aluminum alloy gear housing provides reliability, durability & lighter weight for easy handling
- Forward/reverse rocker switch for convenient one-handed use
- 1/2" square drive with friction ring system that securely holds sockets and adaptors
- Soft grip handle for superior ergonomics
- Ball bearing construction for increased durability
- Improved gearbox structure to avoid oil leaks and enhance product performance
- Packed in a custom case for easy transport and storage

## Specifications:

- Rated Voltage: 120V, 60 Hz
- Input: 7.5A
- Maximum Torque: 240 ft. -lbs.
- No-Load Speed: 2200 rpm
- Blows per Minute: 2,700 bpm
- Drive: 1/2" square

## ⚠ WARNING ⚠

**WARNING:** This product contains chemicals, including lead, known to the State of California to cause cancer, birth defects or other reproductive harm. *Wash hands after handling.*

## General Safety Warnings

**⚠ WARNING:** The instructions and warnings contained in this manual should be read and understood before using or operating this tool. Do not allow anyone to use or operate this tool until they have read this manual and have developed a thorough understanding of how this tool works. Failure to observe any of the following instructions could result in severe personal injury to tool user and bystanders, or cause damage to the tool and property. Keep this manual for future reference.

**📖 Note:** The warnings and cautions discussed in this instruction manual cannot cover all possible conditions and situations that may occur. It must be understood by the operator that common sense and caution are factors which cannot be built into this product, but must be supplied by the operator.

**⚠ WARNING:** Use safety equipment. User and bystanders should use safety goggles or safety glasses with side shields which comply with current national standards, or when needed, a face shield. Use an ANSI approved dust mask or respirator when working around metal, wood, and chemical dusts and mists. Wear hearing protection when using this tool. This applies to all persons in the work area. Also use non-skid safety shoes, hardhat, gloves, and dust collection systems where applicable.

**⚠ WARNING:** Keep bystanders and children out of the work area while operating this tool.

**⚠ WARNING:** Always keep your work area clean, uncluttered, and well lit. Cluttered or dark areas invite accidents and injuries. DO NOT work on floor surfaces that are slippery.

**⚠ WARNING:** Do not operate this tool if you are tired or under the influence of alcohol, drugs, or medications that could affect your ability to use the tool properly.

**⚠ WARNING:** Dress properly. Do not wear loose clothing or jewelry as they can be caught in moving parts. Wear restrictive hair covering to contain long hair.

**⚠ WARNING:** Do not reach over or across running machines. Keep proper footing and balance at all times. Non-skid footwear is recommended when working.

**⚠ WARNING:** This power tool produces an electromagnetic field during operation. This field may under some circumstances interfere with active or passive medical implants. To reduce the risk of serious or fatal injury, we recommend persons with medical implants to consult their physician and the medical implant manufacturer before operating this machine.





# Electrical Safety Warnings

 **WARNING:** Read all safety warnings and instructions. Failure to follow all warnings and instructions may result in electric shock, fire and/or serious injury or death.

 **WARNING:** Before connecting a tool to a power supply, always check to ensure the power supply corresponds to the voltage on the nameplate of the tool. A power supply with a voltage greater than that specified for the tool can result in serious injury to the user, as well as damage to the tool. Using a power supply with a voltage less than the nameplate rating is harmful to the motor. If in doubt, do not plug in the tool.

 **NOTE:** Double insulated tools are equipped with a polarized plug (one blade is wider than the other). This plug will fit in a polarized outlet only one way. If the plug does not fit fully in the outlet, reverse the plug. If it still doesn't fit, contact a qualified electrician to install a polarized outlet. Do not change the plug in any way.

 **WARNING:** To reduce the risk of electric shock, DO NOT use in damp conditions, on wet surfaces, or expose to rain. Do not plug in this tool or operate it with wet hands or while standing in water.

 **WARNING:** Never use the cord for carrying, pulling or unplugging the power tool. Grasp plug and pull to disconnect from outlet. Keep cord away from heat, oil, sharp edges or moving parts. Replace damaged cords immediately.

 **WARNING:** Do not carry the power tool with your finger on the switch. Ensure the switch is in the off position before plugging the tool into the power outlet. In the event of a power failure while a tool is being used, turn the switch off to prevent surprise starting when the power is restored.

 **WARNING:** Always remove the power cord from the electric outlet when making adjustments, changing parts, cleaning or working on the tool.

 **WARNING:** Care should be taken to arrange the cord so it will not be stepped on, tripped over, or otherwise subjected to damage or stress.

 **WARNING:** Never attempt to plug in or operate equipment with defective or damaged wires, power cord or power cord plug. Have any defective or damaged parts replaced immediately by qualified personnel.

 **WARNING:** Avoid body contact with electrically grounded surfaces. There is an increased risk of electric shock if your body is grounded.

 **WARNING:** If the work area is not equipped with a permanently installed Ground Fault Circuit Interrupter outlet (GFCI), use a plug-in GFCI between the power tool or extension cord and the power receptacle.

 **WARNING:** If an extension cord is necessary, use only 'Listed' extension cords. If used outdoors, they must be marked "For Outdoor Use".

 **WARNING:** Use of improper size or gauge of extension cord may cause unsafe or inefficient operation of your tool, or cause damage to your tool. Be sure your extension cord is rated to allow sufficient current flow to the motor. If in doubt, always use a larger gauge cord. Be sure to check the voltage requirements of the tool to your incoming power source.

 **NOTE:** The table below shows the correct size to use according to cord length and the amperage draw of the tool (specified on the nameplate). When in doubt, use the next heavier gauge. The smaller the gauge number, the heavier the cord. (AWG = American Wire Gauge).

Minimum Gauge for Extension Cords (AWG)  
(when using 120 volts only)

Ampere Rating		Total Length of Cord in Feet (meters)			
More Than	Not More Than	25' (7.6m)	50' (15m)	100' (30.4m)	150' (45.7m)
0	6	18	16	16	14
6	10	18	16	14	12
10	12	16	16	14	12
12	16	14	12	Not Recommended	

## Power Tool Use and Care

 **NOTE:** The term "power tool" in the warnings refers to your electrically operated (corded) power tool or battery operated (cordless) power tool.

 **WARNING:** Beware of all power lines, electrical circuits, water pipes and other mechanical hazards in your work area, particularly those below the work surface hidden from the operators view. Unintentional contact with these hazards may cause personal injury or property damage.

 **WARNING:** Do not force the power tool. Use the correct power tool for your application. *The correct power tool will do the job better and safer at the rate for which it was designed.*

 **WARNING:** Do not use the power tool if the switch loses its function. *Any power tool that cannot be controlled with the switch is dangerous and must be repaired.*

 **WARNING:** Do not operate power tools in explosive atmospheres, such as in the presence of flammable liquids, gases or dust. *Power tools create sparks which may ignite the dust or fumes.*

 **WARNING:** Make sure that stored or idle power tools are out of the reach of children and do not allow persons unfamiliar with the power tool or these instructions to operate the power tool. *Power tools are dangerous in the hands of untrained users.*

 **WARNING:** Maintain power tools. Check for misalignment or binding of moving parts, breakage of parts and any other conditions that may affect the power tools operation. If damaged, have the power tool repaired before using it. *Many accidents are caused by poorly maintained power tools.*

 **WARNING:** If devices are provided for the connection of dust extraction and collection facilities, ensure that these are connected and properly used.

 **WARNING:** Remove adjusting keys or wrenches before turning the tool on. *A wrench or a key that is left attached to a rotating part of the tool may result in personal injury.*

 **WARNING:** Have your power tool serviced by a qualified repair person using only identical replacement parts. This will ensure that the power tool is safe.

## Repetitive Motion / Vibration Hazards

 **WARNING:** Avoid prolonged exposure to vibration. Vibration, repetitive motions, or uncomfortable positions over extended periods of time may be harmful to your hands and arms. Do not ignore symptoms or persistent or recurring discomfort, pain, throbbing, aching, tingling, numbness, burning sensation, or stiffness. Discontinue use of the tool and seek medical advice before resuming use.

 **WARNING:** Adopt a comfortable posture while maintaining secure footing and avoiding awkward or off balance postures. Changing posture during extended tasks can help avoid discomfort and fatigue.

## Functions

The voltage specifications on the rating plate must correspond with the supply voltage.  
Before attempting to use your tool, familiarize yourself with all operating features and safety requirement.

1. Switch
2. Brush Cap
3. Gear Housing
4. Handle
5. Motor Housing

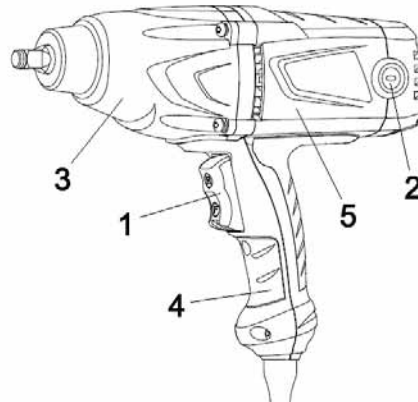

## Operating Instructions

### Switch

This impact wrench is equipped with a rocker switch that switches rotation from clockwise to counter-clockwise easily, allowing fasteners to be broken loose. Pressing the lower part of the switch causes the impact wrench to move clockwise; pressing the upper part of the switch causes the rotation to reverse.

### Install/remove socket

To install a socket on the anvil, align the hole of the socket with the anvil, push firmly.  
To remove a socket from the anvil, pull the socket out firmly.

## Maintenance

### UNPLUG THE IMPACT WRENCH BEFORE PERFORMING ANY MAINTENANCE

- Do not attempt to make any adjustments while the tool is in operation.
- Clean out any accumulated dust regularly.
- Do not allow petroleum based products to come into contact with plastic parts as they contain chemicals that can damage, weaken or destroy plastic.
- This impact wrench will require lubrication after 30 continuous hours or 50 intermittent hours of use. Remove the screws for the gear box as shown below (two on each side), and lubricate the gears. Use Exxon Mobil lubricants LITH SHC 460 PL35LB or equivalent to lubricate as needed.
- Damaged carbon brushes (burnt, broken or less than 5mm) must be changed.

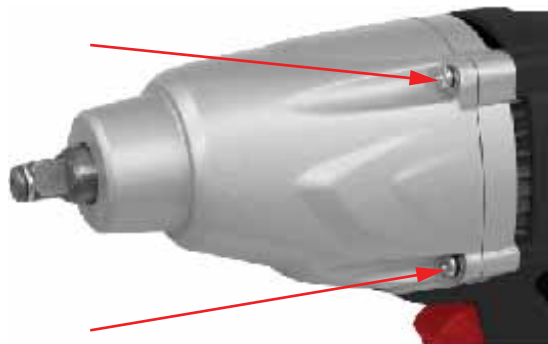

- The brushes should be checked periodically for repair. Loosen the plastic caps located on the side of the motor housing to reveal the spring and brush assembly.
- When replacing the old carbon brushes, the new brushes must slide into the brush holder easily. **DO NOT FORCE BRUSHES INTO THE HOLDER.**
- The normal size of the carbon brushes is shown below:

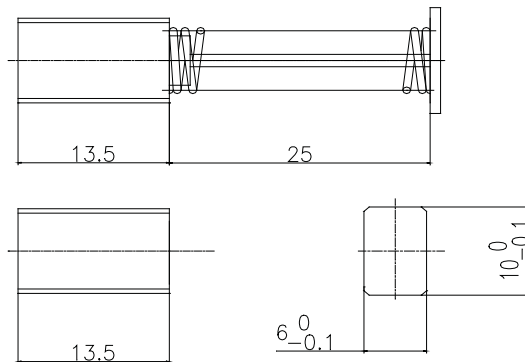

## Troubleshooting

Problem	Possible Causes	Likely Solutions
Tool will not start.	<ol style="list-style-type: none"> <li>1. Cord not connected.</li> <li>2. No power at outlet.</li> <li>3. Internal damage or wear. (Carbon brushes or switch, for example.)</li> </ol>	<ol style="list-style-type: none"> <li>1. Check that cord is plugged in.</li> <li>2. Check power at outlet. If outlet is unpowered, turn off tool and check circuit breaker. If breaker is tripped, make sure circuit is right capacity for tool and circuit has no other loads.</li> <li>3. Have technician service tool.</li> </ol>
Tool operates slowly.	<ol style="list-style-type: none"> <li>1. Excess pressure applied to workpiece.</li> <li>2. Power being reduced by long or small diameter extension cord.</li> </ol>	<ol style="list-style-type: none"> <li>1. Decrease pressure, allow tool to do the work.</li> <li>2. Eliminate use of extension cord. If an extension cord is needed, use one with the proper diameter for its length and load. See <i>Extension Cords</i> in <i>GROUNDING</i> section.</li> </ol>
Performance decreases over time.	Carbon brushes worn or damaged.	Have qualified technician replace brushes.
Excessive noise or rattling.	Internal damage or wear. (Carbon brushes or bearings, for example.)	Have technician service tool.
Overheating.	<ol style="list-style-type: none"> <li>1. Forcing tool to work too fast.</li> <li>2. Blocked motor housing vents.</li> <li>3. Motor being strained by long or small diameter extension cord.</li> </ol>	<ol style="list-style-type: none"> <li>1. Allow tool to work at its own rate.</li> <li>2. Wear ANSI-approved safety goggles and NIOSH-approved dust mask/respirator while blowing dust out of motor using compressed air.</li> <li>3. Eliminate use of extension cord. If an extension cord is needed, use one with the proper diameter for its length and load. See <i>Extension Cords</i> in <i>GROUNDING</i> section.</li> </ol>



**Follow all safety precautions whenever diagnosing or servicing the tool. Disconnect power supply before service.**

# ATD®

## ATD-10522

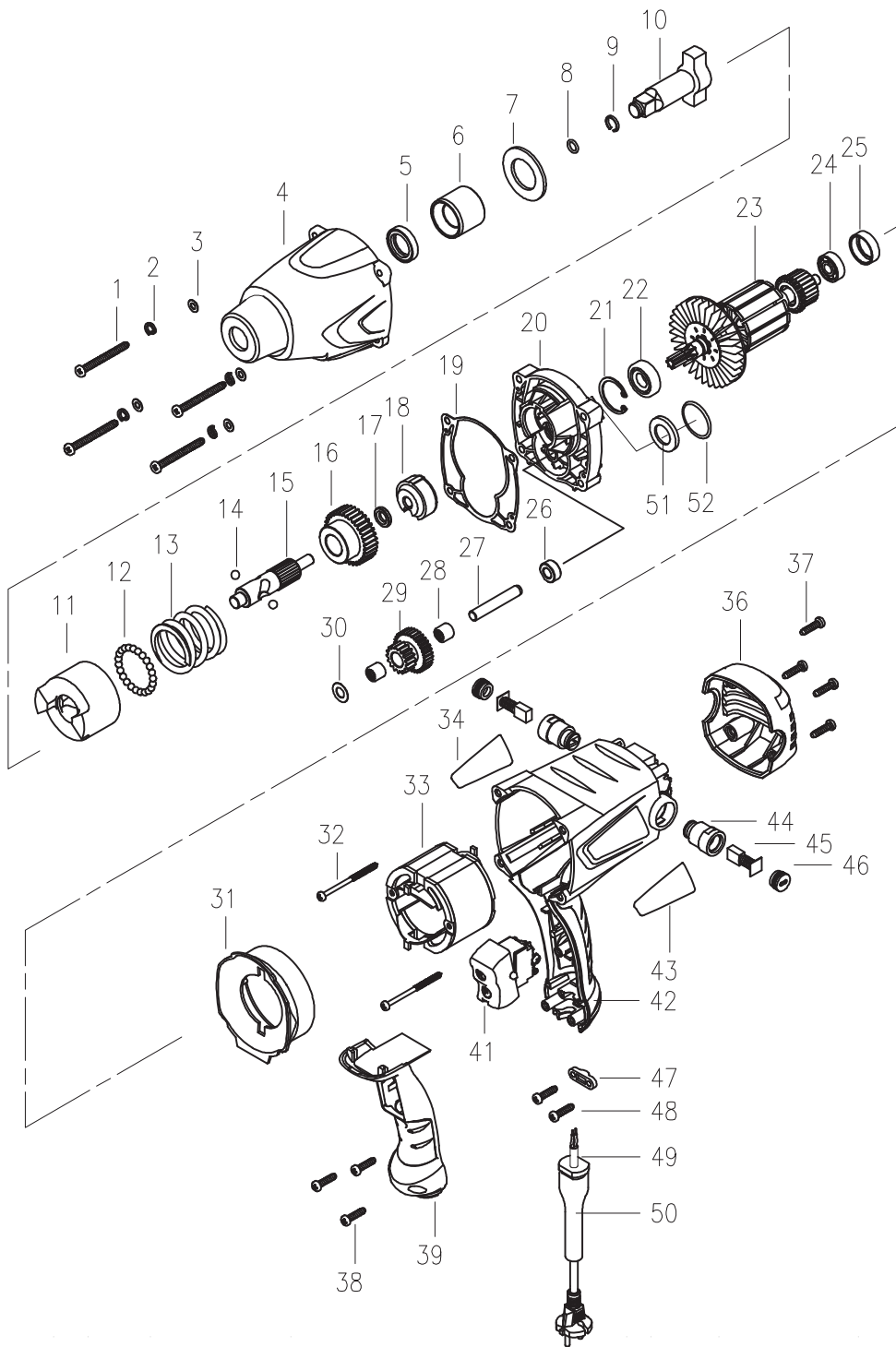

ITEM#	ORDERING PART#	PART DESCRIPTION
1	PRT10522-01	SCREW ST5X48F
2	PRT10522-02	SPRING WASHER/Φ6
3	PRT10522-03	WASHER/Φ6
4	PRT10522-04	GEAR BOX
5	PRT10522-05	SEALING RING BUSHING
6	PRT10522-06	FRICITION BEARING
7	PRT10522-07	WASHER
8	PRT10522-08	SNAP RING
9	PRT10522-09	O-RING/Φ8XΦ1.5
10	PRT10522-10	SPINDLE
11	PRT10522-11	IMPACT BLOCK
12	PRT10522-12	STEEL BALL/Φ6
13	PRT10522-13	SPRING
14	PRT10522-14	STEEL BALL/Φ7.14
15	PRT10522-15	GEAR SHAFT
16	PRT10522-16	GEAR
17	PRT10522-17	WASHER/Φ8.1XΦ16X3
18	PRT10522-18	BRACKET
19	PRT10522-19	SEALING RING
20	PRT10522-20	GEAR BOX COVER
21	PRT10522-21	CIRCLIP FOR HOLE
22	PRT10522-22	BALL BEARING/6001.2RS
23	PRT10522-23	ARMATURE
24	PRT10522-24	BALL BEARING/608.2Z

ITEM#	ORDERING PART#	PART DESCRIPTION
25	PRT10522-25	BEARING BUSH
26	PRT10522-26	WASHER/Φ6.2X7.2
27	PRT10522-27	PIN/Φ8X50
28	PRT10522-28	NEEDLE BEARING/HK081210
29	PRT10522-29	COUPLE GEAR
30	PRT10522-30	WASHER/Φ8XΦ16X0.5
31	PRT10522-31	BAFFLE
32	PRT10522-32	SCREW/ST4X60C
33	PRT10522-33	STATOR
36	PRT10522-36	REAR COVER
37	PRT10522-37	SCREW ST4X16F
38	PRT10522-38	SCREW/ST4X18F
39	PRT10522-39	HANDLE COVER
41	PRT10522-40	SWTICH
42	PRT10522-42	HOUSING
44	PRT10522-44	BRUSH HOLDER
45	PRT10522-45	CARBON BRUSH
46	PRT10522-46	BRUSH HOLDER CAP
47	PRT10522-47	CORD CLAMP
48	PRT10522-48	SCREW/ST4X16C
49	PRT10522-49	CORD
50	PRT10522-50	CORD SLEEVE
51	PRT10522-51	FELT RING
52	PRT10522-52	O-RING





**WARRANTY**  
**1 YEAR LIMITED WARRANTY**

**THIS WARRANTY AND CONFIRMED RECEIPT(S) SHOULD BE RETAINED BY THE CUSTOMER AT ALL TIMES**

PURCHASED FROM: \_\_\_\_\_

DATE PURCHASED: \_\_\_\_\_

INVOICE/RECIPT NUMBER: \_\_\_\_\_

Your ATD-10522 is warranted for a period of 12 months from the original purchase date.

For a period of one (1) year from your purchase date, ATD Tools Inc. will repair or replace (at its option) without charge, your ATD product if it was purchased new and the product has failed due to a defect in material or workmanship which you experienced during normal use of the product. This limited warranty is your exclusive remedy.

To access the benefits of this warranty, contact your supplier, or point of sale directly. You may be advised to return the product under warranty, freight prepaid, to your supplier for warranty determination.

If this ATD product is altered, abused, misused, modified, or undergoes service by an unauthorized technician, your warranty will be void. We are not responsible for damage to ornamental designs you place on this ATD product and such ornamentation should not cover any warnings or instructions or they may void the warranty. This warranty does not cover scratches, superficial dents, and other abrasions to the paint finish that occur under normal use. It also does not cover noremal wear items such as but not limited to brushes, batteries, drill bits, drill chucks, pads or blades.

Subject to the law in your state:

- (1) Your sole and exclusive remedy is repair or replacement of the defective product as described above.
- (2) ATD is not liable for any incidental damages, including but not limited to, lost profits and unforeseeable consequences.
- (3) The repair and replacement of this product under the express limited warranty described above is your exclusive remedy and is provided in lieu of all other warranties, express or implied. All other warranties, including implied warranties and warranties of merchantability or fitness for a particular purpose are disclaimed and, if disclaimer is prohibited, these warranties are limited to one year from your date of purchase of this product.

Some states' laws do not allow limited durations on certain implied warranties and some states' laws do not allow limitations on incidental or consequential damages. You should consult the law in your state to determine how your rights may vary.

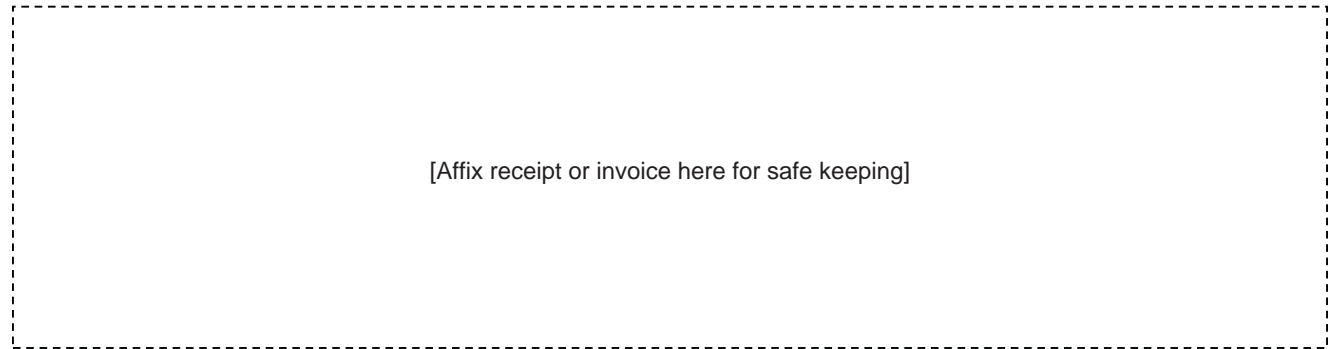

[Affix receipt or invoice here for safe keeping]