

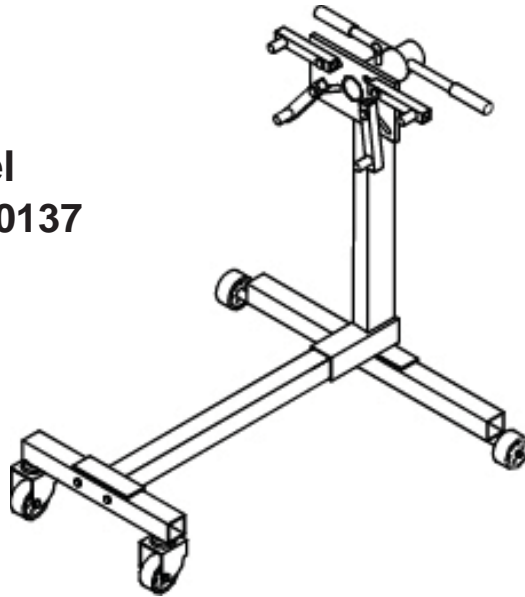

Engine Stand Owner's Manual

Model
ATD-10137



Capacity
750 lb.



This is the safety alert symbol. It is used to alert you to potential personal injury hazards. Obey all safety messages that follow this symbol to avoid possible injury or death.

ADVERTENCIA

- Leer, comprender, y seguir las instrucciones antes de utilizar el aparato.
- El manual de instrucciones y la información de seguridad deben estar comunicados en lengua del operador antes del uso.
- No seguir estas indicaciones puede causar daños personales o materiales.

WARNING

To avoid **crushing and related injuries**:



NEVER work on, under or around a load supported only by engine crane.
ALWAYS use adequately rated engine stand.

Read this manual and follow all the Safety Rules and Operating Instructions before using this product.

WARNING

WARNING: This product may contain chemicals, including lead, known to the State of California to cause cancer, birth defects or other reproductive harm. *Wash hands after handling.*

SAFETY and GENERAL INFORMATION

Save these instructions. For your safety, read, understand, and follow the information provided with and on this engine stand before using. The owner and/or operator of this equipment shall have an understanding of engine stand and safe operating procedures before attempting to use. The owner and/or operator shall be aware that the use and repair of this product may require special skills and knowledge. Instructions and safety information shall be conveyed in the operator's native language before use of this engine stand is authorized. If any doubt exists as to the safe and proper use of this product, remove from service immediately.

Inspect before each use. Do not use if broken, bent, cracked, or damaged parts (including labels) are noted. Any engine stand that appears damaged in any way, operates abnormally or is missing parts, shall be removed from service immediately. If you suspect that the engine stand was subjected to a shock load (a load dropped suddenly, unexpectedly upon it), immediately discontinue use until it has been checked by a factory authorized service center (contact distributor or manufacturer for list of authorized service centers). It is recommended that an annual inspection be done by qualified personnel. Labels and owner's manuals are available from manufacturer.

PRODUCT DESCRIPTION

This Engine Stand is designed to safely support a rated capacity engine during that time that the engine is being rebuilt or repaired.

! *Do not use this device for any purpose other than that for which it is expressly intended.*

SPECIFICATIONS

Model	Capacity	Base Size (L x W)	Overall Height	Head Plate (L x H x Thickness)	Front/Rear Wheel Diameter	Weight
ATD-10137	750 lbs.	31-1/2" x 30-5/8"	35-3/4"	9-7/8" x 5" x 3/8"	3" / 3-1/2"	45 lbs.

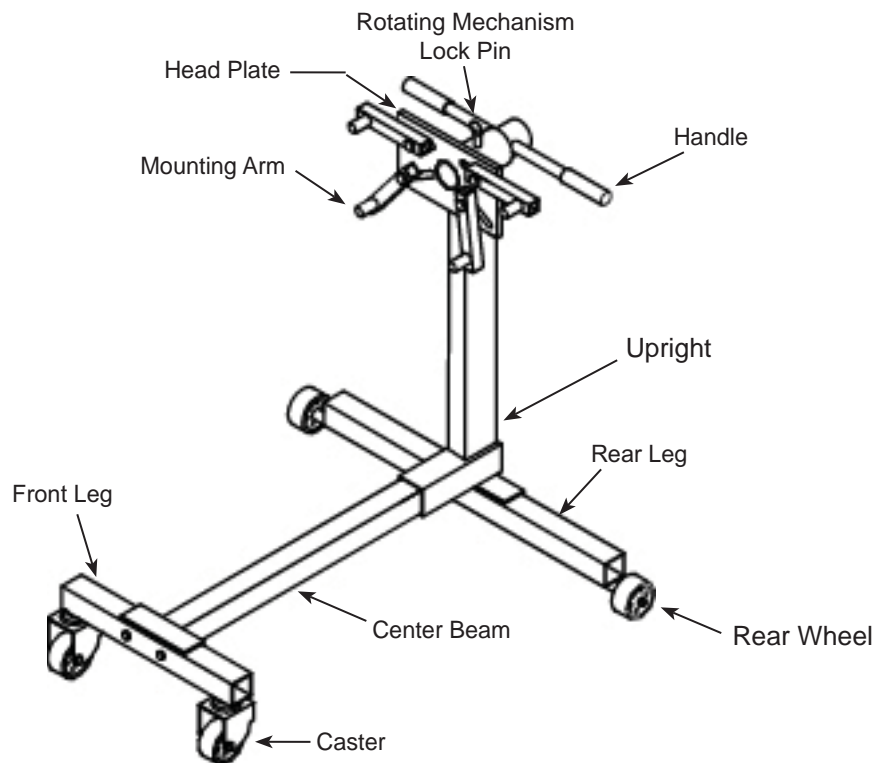

Figure 1 - ATD-10137 components

ASSEMBLY

Model ATD-10137:

1. Attach caster (#13) to front leg (#14) with bolts, washers & and nuts (#15, 16 & 17).
2. Attach wheels (#12) to rear leg (#22) with washers & E-ring (#11 & 10).
3. Attach front leg (#14) to center beam (#21) with bolts, washers & nuts (#18, 19 & 20).
4. Attach upright (#27) and center beam (#21) to rear leg (#22) with bolts, flat washers, lock washers & nuts (#23, 24, 25 & 26) up from the bottom.
5. Slide head plate assembly (#9) into collar at top of upright (#27). Align holes and slide in lock pin (#3).
6. Attach all four mounting arms (#8) to head plate (#9) with bolts, flat washers, lock washers & nuts (#7, 6, 5 & 4) as shown. Mounting arms can be adjusted to most engines.
7. Insert handle (#2) into hole in head plate.
8. Place handle grip (#1) on each end of handle.

Note: Check all fasteners for tightness, tighten where required.

Size of Hardware Kits		Qty
4 -Nut	M14	4
5 -Lock Washer	M14	4
6 -Flat Washer	M14	4
7 -Bolt	M14x60	4
10 -E-ring	M15	2
11 -Flat Washer	M20	4
15 -Bolt	M8x16	8
16 -Lock Washer	M8	8
17 -Nut	M8	8
18 -Bolt	M10x70	2
19 -Lock Washer	M10	2
20 -Nut	M10	2
23 -Bolt	M12x80	1
24 -Flat Washer	M12	1
25 -Lock Washer	M12	1
26 -Nut	M12	1

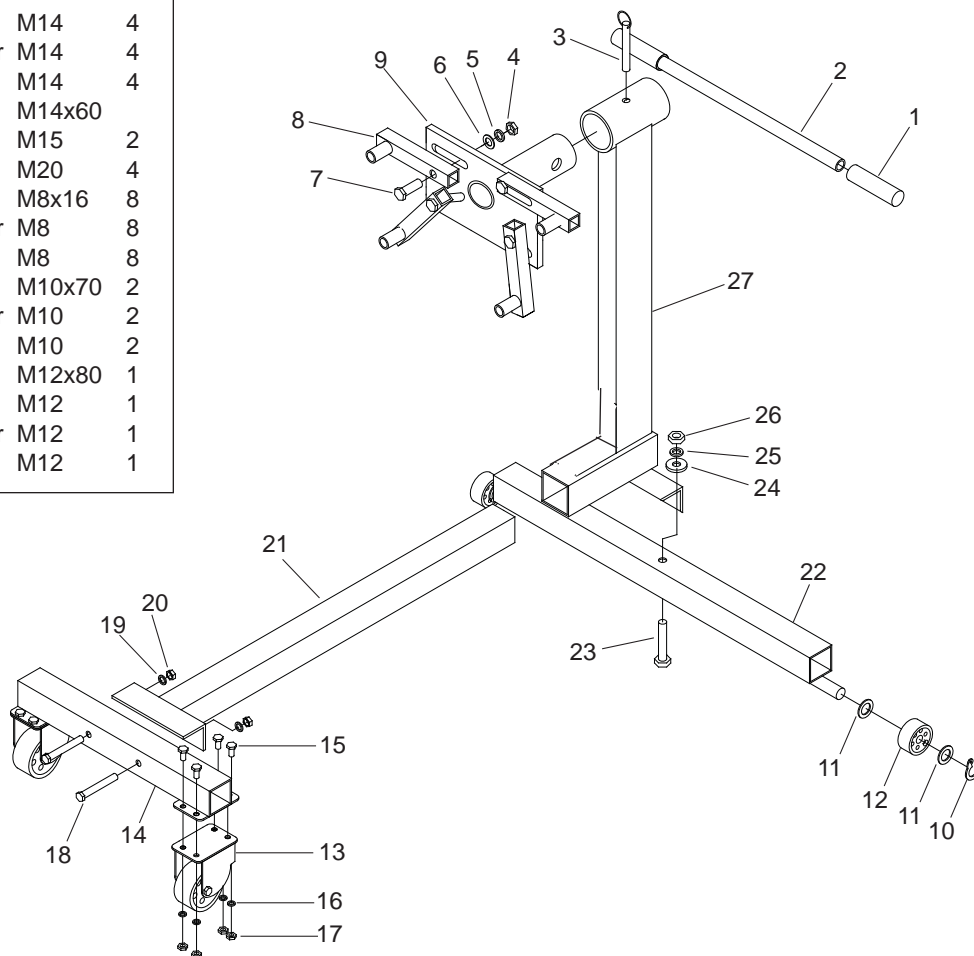

Figure 2 - Assembly illustration for model ATD-10137

BEFORE USE

1. Before using this product, read the owner's manual completely and familiarize yourself thoroughly with the product and the hazards associated with its improper use.
2. Verify that the product and the application are compatible, if in doubt call for technical assistance (888) 332-6419.
3. Inspect engine stand before each use. Do not use if there are bent, broken or cracked components (including labels).
4. Ensure that casters/ wheels and adapter plate rotate freely. Check for and tighten any loose assemblies.

WARNING

- **Study, understand, and follow all instructions** provided with/on this device **before use**.
- **Do not** exceed rated capacity.
- Use **only** on a hard, level surface.
- **Lock** head plate rotating mechanism **before applying load**.
- Use original engine mounting bolts or hardened, appropriate size bolts to secure engine to stand.
- Ensure engine is centered and secured to the head plate. Off-center loading may cause the engine to rotate unexpectedly and cause the loaded stand to tip over.
- Unlock and apply rotating mechanism slowly and carefully.
- Do not modify nor substitute hardware to this device.
- Only attachments and/or adapters supplied by the manufacturer shall be used.
- Do not use the device for any purpose other than that for which it is intended.
- Failure to heed these markings may result in personal injury and/or property damage.

WARNING

- The paint on this product contains lead, a chemical known in the State of California to cause cancer, birth defects and other reproductive harm.
- Do not ingest paint chips and keep product away from children.
- Wash hands after each use.

OPERATION

 **ALWAYS** verify that the product and the application are compatible. **NEVER** load the engine stand with an engine that extends beyond an imaginary line drawn connecting the centerlines of the front and rear wheel/ caster axles as show in Fig 3.

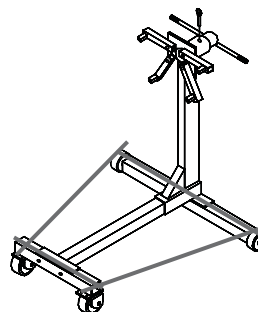



Figure 3 - Peripheral Loading Limit of Engine Stand

1. Ensure application is compatible with product.
2. Align engine with stand, then adjust mounting arms to match bell housing mounting bolt holes. Rotational lock must be secure before applying load.
3. Carefully secure engine so that load is centered on stand. Secure with high strength stud bolts and flat washers. Ensure threads are compatible with your engine, and use washers on both sides of head plate.
4. To rotate engine, slowly and carefully release locking mechanism. Use original handle to rotate, then secure by engaging locking mechanism (see Fig.1 & 2).
5. Check to ensure stand is secure before working on or around stand. Never work under loaded stand.

 Use **only** the handle provided by the manufacturer. The handle provided with this stand will safely engage and operate the head plate. If the handle is worn, bent, or otherwise damaged, **STOP**, discontinue use of the stand until a factory replacement handle assembly can be acquired.

MAINTENANCE

Periodically inspect each stand. Ensure all parts move freely. Lubricate the wheels and casters periodically. To help prevent rust, wipe clean after each use. If rust appears, cover with suitable utility paint.

 **Paint contains lead!**
DO NOT sand or grind painted surface!

Storage

Store the engine stand in clean, dry environment. This will help prevent rust and corrosion.

REPLACEMENT PARTS

Not all components of the jack are replacement items, but are illustrated as a convenient reference of location and position in the assembly sequence. When ordering parts, give model number, part number and description below. Call your distributor for current pricing.

Item	Part#	Description
1	T093-00002-000	Handle
2	T093-04000-000	Lock Pin
3	T093-03000-000	Head Plate
4	T093-05000-000	Mounting Arm
5	T093-00001-000	Wheel
6	T093-08000-000	Caster, 3"
-	T093-09000-000	Hardware Kit

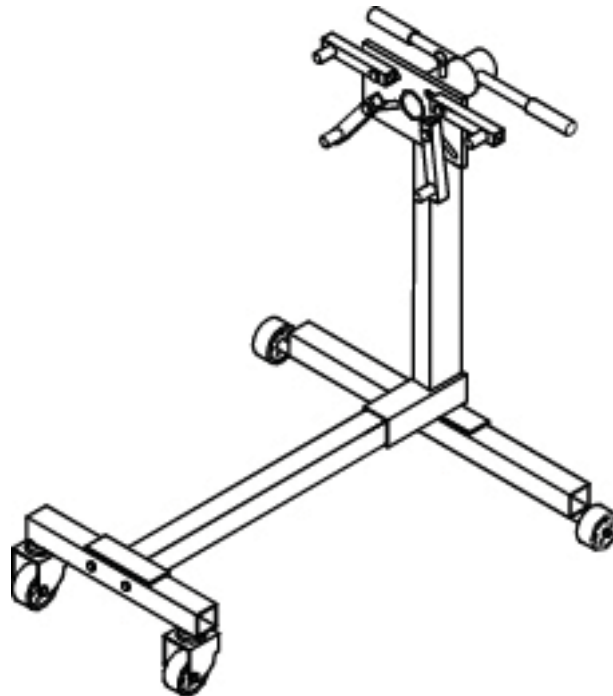

Figure 4 - Replacement Parts Illustration for model ATD-10137

ONE YEAR LIMITED WARRANTY

For a period of one (1) year from date of purchase, **ATD Tools, Inc.** will repair or replace, at its option, without charge, any of its products which fails due to a defect in material or workmanship, or which fails to conform to any implied warranty not excluded hereby.

Performance of any obligation under this warranty may be obtained by contacting your distributor or point of sale for further instructions. Please retain your proof of purchase, as it will be needed for any claim.

Except where such limitations and exclusions are specifically prohibited by applicable law, (1) the CONSUMER'S SOLE AND EXCLUSIVE REMEDY SHALL BE THE REPAIR OR REPLACEMENT OF DEFECTIVE PRODUCTS AS DESCRIBED ABOVE, and (2) **ATD Tools, Inc.** SHALL NOT BE LIABLE FOR ANY CONSEQUENTIAL OR INCIDENTAL DAMAGE OR LOSS WHATSOEVER, and (3) THE DURATION OF ANY AND ALL EXPRESSED AND IMPLIED WARRANTIES, INCLUDING WITHOUT LIMITATION, ANY WARRANTIES OF MERCHANTABILITY AND FITNESS FOR A PARTICULAR PURPOSE, IS LIMITED TO A PERIOD OF ONE (1) YEAR FROM DATE OF PURCHASE.

Some states do not allow limitations on how long an implied warranty lasts, so the above limitation may not apply to you. Some states do not allow the exclusion or limitation of incidental or consequential damages, so the above limitation or exclusion may not apply to you. This warranty gives you specific legal rights, and you may also have other rights which vary from state to state.

