



# ATD-8401

## 40 LBS. PRESSURE BLASTER

### INSTRUCTION MANUAL

ATD abrasive blasting equipment is designed for cleaning and removing rust, scale, paint and dirt. It is the ideal method for stripping, polishing and etching projects. This equipment can be used with abrasive powders and liquids. This model is equipped with the standard use ceramic nozzle.

#### **SAFETY WARNING & CAUTIONS:**



**WARNING: Airborne dust:** This is one of the most serious hazards associated with blasting operations. When evaluating this hazard, it's important to consider the concentration of dust and the size of particles. Larger particles, considered "nuisance" dust, are normally filtered out in the nose and throat. Smaller particles (10 microns or smaller) can bypass the lung's filtering system and penetrate deep into the respiratory system, where they may cause serious damage. Safeguards are needed when smaller particles are present in the working environment.

**Metal dust,** in addition to the abrasive being used, contributes to the generation of airborne dust. Metals such as lead, cadmium, and manganese, can be extremely toxic when inhaled. Many existing paints have a lead base. Regulations require special handling, trained personnel, and medical monitoring when lead is present. If in doubt, check it out. Don't guess.

**Silica sand:** This product is a potentially serious health hazard and should NOT be used as an abrasive. If silica containing (quartz) materials are selected for any reason, workers must wear a positive pressure or pressure demand respirator with an assigned protection factor (APF) of either 1000 or 2000. Silica must be contained and disposed of properly. Even if a wet blasting method is selected, silica that is allowed to migrate by either wind or water, will eventually become an airborne contaminant.

**Air supply:** Air-supplied respirators must be used (1) when working inside of blast cleaning rooms, (2) when using portable units in areas without enclosure, and (3) under any circumstances where the operator is not physically separated from the abrasive material by an exhausted enclosure. If airline respirators and compressors are used, make sure the intake hose is placed in an area that provides clean air. An attendant should be in the area at all times, monitoring breathing air and assuring the blaster's safety.

**Additional personal protective equipment:** Blasting operations create high noise levels, so hearing protection is a must--for both the operator and nearby workers! Operators should also use heavy canvas or leather gloves, aprons, or leggings when appropriate, as well as safety shoes.

**Handling and storing abrasives:** Dust is nearly always created at any point where abrasives are transferred, whether by hand or shovel. Therefore, all points of transfer must be properly exhausted and workers who handle abrasives manually should wear particulate filter respirators.

**⚠️ WARNING:** When using pneumatic equipment, basic safety precautions should always be followed to reduce the risk of personal injury and hazards due to over pressurization.

**⚠️ WARNING:** Some dust created by abrasive blasting, grinding, and other construction activities contains chemicals known to the State of California to cause cancer, birth defects, or other reproductive harm. Your risk from exposure varies, depending on how often you do this work. To reduce your exposure to these chemicals: work in a well-ventilated area, and with approved safety equipment, such as dust masks that are specifically designed to filter out microscopic particles.

**⚠️ WARNING:** Always wear eye protection that complies with a recognized standard (CSA or ANSI) when operating or performing maintenance on this tool. User and bystanders.

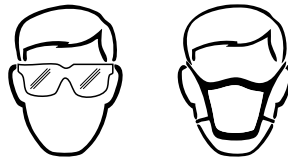

## **READ ALL INSTRUCTIONS BEFORE USING:**

1. Keep work area clean. Cluttered areas invite injuries.
2. Observe work area conditions. Do not use unit in damp, wet or poorly lit locations. Don't expose to rain. Keep work area well lit. Do not use electrically powered air compressors in the presence of flammable gases or liquids.
3. Keep children away. Children must never be allowed in the work area.
4. Do not use inappropriate attachments in an attempt to exceed the unit capacities.
5. Dress properly. Do not wear loose clothing or jewelry as they can be caught in moving parts. Non-skid footwear is recommended. Always wear the hood (included), a dust mask and heavy-duty canvas gloves.
6. Use eye and ear protection. Always wear ANSI approved chemical splash goggles when working with chemicals. Wear an ANSI approved dust mask or respirator when working around metal, wood and chemical dusts and mists.
7. Do not overreach. Keep proper footing and balance at all times. Do not reach over or across running machines.
8. Keep machine clean for better and safer performance. Follow the instructions for lubricating and changing accessories. Inspect compressors cord periodically and if damaged have it repaired by a qualified technician. Inspect all hoses for leak prior to use. The handle must be kept clean, dry and free from oil and grease at all times.
9. Be sure that keys and adjusting wrenches are removed from the unit or work surface before using.

10. Make sure the air pressure adjustment is set at "0 PSI" and the shut off valve is in the off position when not in use and before attaching the air compressor.
11. Do not operate the unit when tired or under the influence of alcohol or drugs.
12. Before using check for alignment and binding of moving parts, any broken parts or mounting fixtures and any other conditions that may affect proper operation. Do not use the unit if any switch does not turn on or off properly.
13. When servicing only use parts and accessories intended for use with this unit.
14. Drain water trapped in the air pressure adjuster periodically.
15. Do not allow pressure blaster to be pressurized while unattended or not in use.
16. Make sure all equipment is rated to the appropriate capacity. Make sure that regulator is set no higher than 125PSI.
17. Periodically check the abrasive medium delivery equipment. Valves, hoses and nozzles that carry the abrasive medium after it leaves the pressure tank are subjected to the abrasive blasting action and will wear out more quickly than other components.
18. Release the air pressure in the tank before opening. Open the shut off valve to release pressure. Make sure pressure gauge reads "0 PSI" before opening the tank. Do not attempt any repairs to the pressure blaster until the gauge reads "0 PSI".
19. Maintain correct air pressure whenever working. Do not allow pressure to exceed 125 PSI. If the safety valve does not release excess air pressure, stop all work and open the shut off valve to release pressure in the tank.

 **WARNING:** The warnings and cautions discussed in this instruction manual cannot cover all possible conditions and situations that may occur. It must be understood by the operator that common sense and caution are factors that cannot be built into this product but must be supplied by the operator.

## **ASSEMBLY:**

**NOTE:** Use Teflon pipe tape on all threaded joints. Make sure all joints are securely tightened.

### **Legs, Wheels and Handle Bar Assembly (Refer to Fig 1):**

1. Attach both the left leg (#7) and the right leg (#17) to the tank (#15) using the four screws & nuts. The bottom section of the two legs must point outward respectively and the holes in the bottom of the legs must be parallel to each other to accommodate the axle (#25).
2. Attach one of the wheels (#16) to the axle (#25) using one of the cotter pins (#14).
3. Slide the axle through the holes in the bottom of the two legs, using four cotter pins (#14) to fix the position of the axle.

4. Attach the other wheel (#16) to the axle (#25) using the remaining cotter pin (#14).
5. Slide the handle bar (#6) onto the left leg (#7) and the right leg (#17) and secure it with two self-tapping screws.
6. Slide the two end caps (#18) over the ends of the legs (# 7 & # 17)

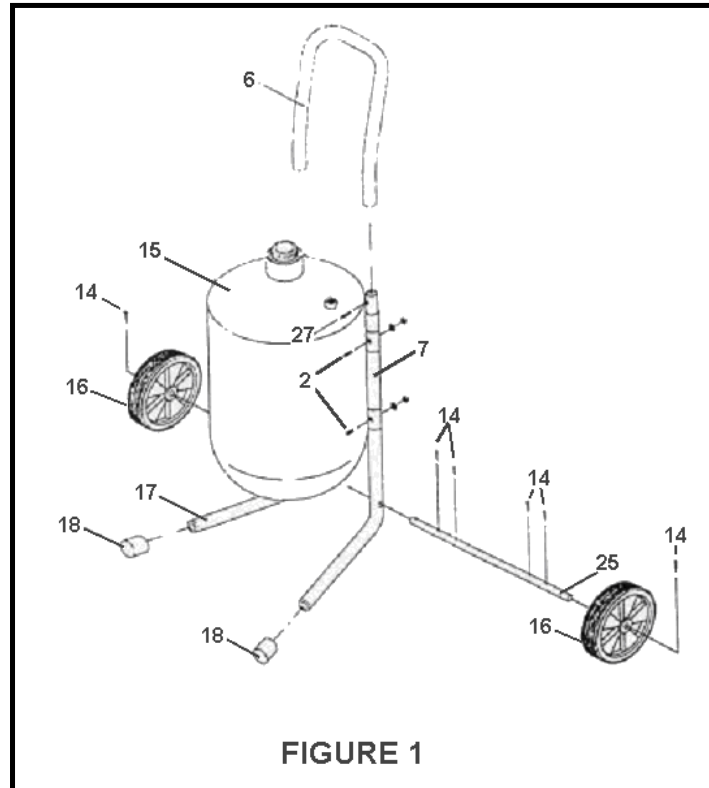

### **Abrasive Metering Valve and Abrasive Gun Assembly (Refer to Fig 2):**

1. Attach the abrasive metering valve (#26) to the side hole of the intake manifold (#12). Attach one of the elbow connectors(#13) and one of the hose adaptor (#23) to either remaining hole of the intake manifold (#12)
2. Attach the other side of the abrasive metering valve (#26) to the bottom of the tank.
3. Slide the hose clamp (#22) over either side of the abrasive hose (#21). Do not tighten yet.
4. Slide the two ends of the abrasive hose (#21) onto the abrasive gun (#24) respectively. Tighten the hose clamps (#22) very securely.

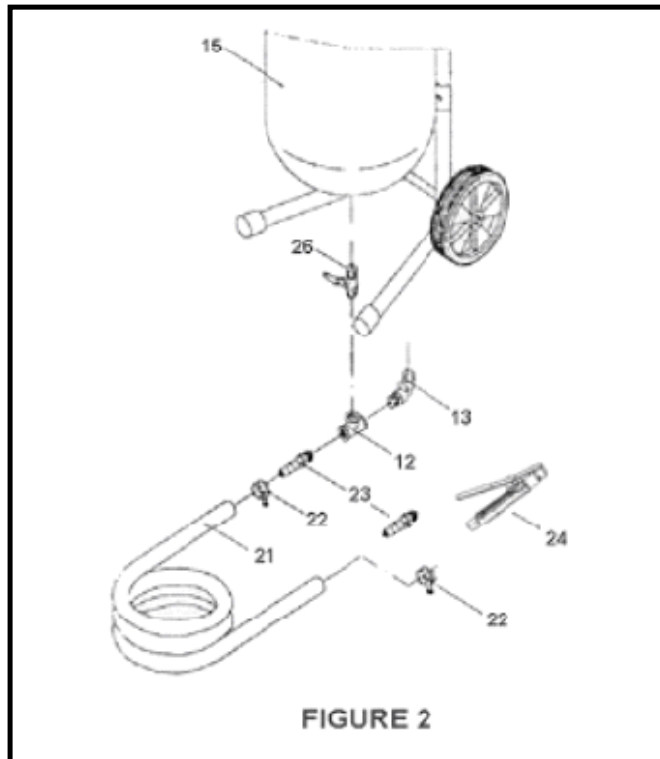

### **Air Pressure Adjuster and Safety Valve Assembly (Refer to Fig 3):**

**Use PTFE tape on all air fitting threads.**

1. Attach the connector (#8) to one of the side inlets of the air pressure adjuster (#9). Attach the intake manifold (#12) to the other side of the nipple connector (#11). Make sure the pressure gauge on the air pressure adjuster and the front inlet of the intake manifold face the same direction, as in figure 3.
2. Attach the joint pipe (#10) to the front intake of the intake manifold (#12). Attach the other side of the joint pipe to the threaded port on the top of the tank (#15).
3. Attach the safety valve (#5) onto the threaded port on top of the tank (#15).
4. Screw the tank filler cap (#4) onto the filler opening with o-ring (#3) in between to ensure an airtight seal.
5. Attach the elbow connector (#13) to the remaining side port of the intake manifold (#12). Make sure the other end of the elbow connector points to the other elbow connector in the bottom assembly (#13 from figure 2).
6. Attach the two ends of the air hose (#20) to the two elbow connectors (#13) in the top assembly and the bottom assembly respectively.

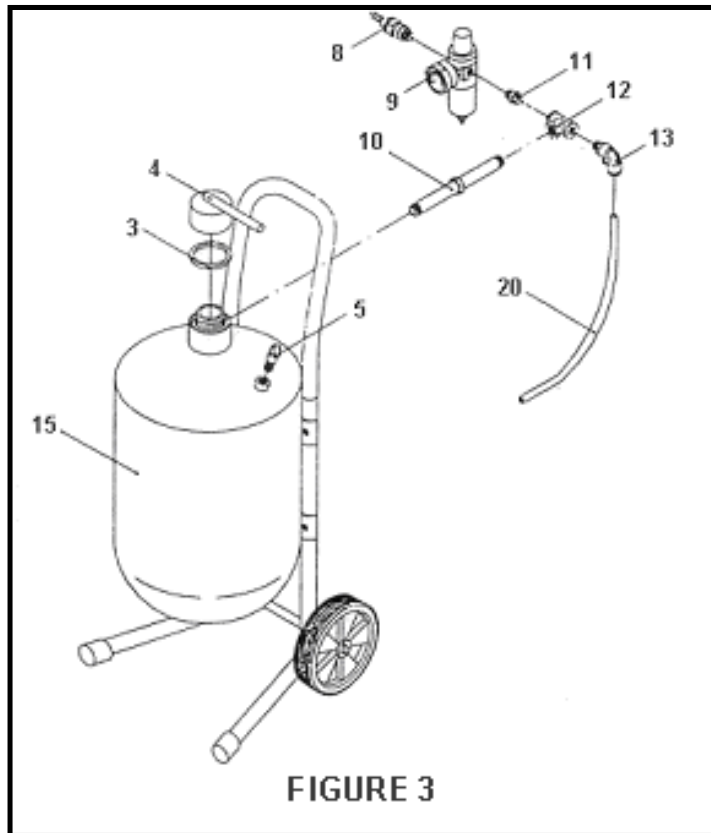

### OPERATION:

**⚠ WARNING: Always wear your hood, dust mask and heavy-duty canvas gloves when operating.**

1. Close the abrasive metering valve (#26), pour about 25 lbs of abrasive medium into the tank. Then close the tank filler cap (#4) securely, assuring that o-ring (#3) is in place.
2. Turn the air pressure adjuster (#9) counter-clockwise (lowest pressure) fully. With the air compressor off, attach the connector (#8) to an air supply hose coming from the air compressor. Tighten securely with a hose clamp.
3. Switch on power to start up the air compressor. Check for leaks at the tank filler cap (#4) and along all hoses and fittings as pressurization begins.
4. Turn the air pressure adjuster (#9) slowly clockwise until the pressure gauge reads a desired value.
5. Open the abrasive metering valve (#26) and push down the control level of the abrasive gun (#24) to an appropriate position to gain a desired abrasive flow.
6. To shut the unit down, close the abrasive metering valve (#26) and turn the air pressure adjuster (#9) counter-clockwise until the pressure gauge reads "0 PSI". Push down the control level of the abrasive gun (#24) to release any extra air, and to be sure that the air supply is off.
7. If there is too much water trapped in the air pressure adjuster (#9), open the bottom valve to drain the water.

## AIR/ABRASIVE SUPPLY REQUIREMENTS

Hose ID	Hose Length	Nozzle ID	Compressor HP	CFM @125PSI	ABRASIVE USE PER HOUR
3/8"	50ft	0.076"	2	6	30lbs
3/8"	25ft	0.098"	4	12	80lbs
1/2"	50ft	0.118"	7	20	120lbs
1/2"	25ft	0.132"	10	25	150lbs

We recommend that air pressure in the range of 65-125PSI will provide the best results

### MAINTENANCE:

1. Keep your pressure blaster clean and protect from damage.
2. Depressurize after using.
3. When initially pressurizing, check for leaks at the tank top and at all hoses and fittings. Leaking joints may be repaired by replacing worn or damaged Teflon tape at joints.
4. Check for worn abrasive hose and fittings. The abrasive metering valve, manifold and all parts after the abrasive is ejected from the tank are subject to rapid wear, due to the flow of abrasive. Watch especially for leaks, blistering bulging or thinness of the hose. Replace any parts which appear worn.

### ABRASIVE SELECTION:

The kind of abrasive you choose will greatly influence the amount of time needed to clean a given surface area. Abrasive materials include silicon carbide, alumina and many others.

Be sure that the abrasive you use is thoroughly dry. Damp abrasive can cause clogging of your pressure blaster.

While you may reuse abrasive, remember that the abrasive does wear out. After using, abrasive becomes smoother and rounder, thus reducing abrasive effectiveness.

Reusing abrasive may also cause clogging due to debris contained in the mixture from prior use.

### ABRASIVE FLOW ADJUSTMENT

Choose a larger nozzle for a broader spray pattern. Choose a smaller nozzle for more focused abrasive blasting.

Adjust air pressure with the air pressure adjuster (#9). Adjust abrasive flow with abrasive metering valve (#26).

Watch for abrasive clogging. Depressurize if necessary and replace the abrasive with drier or cleaner abrasive.

## SAFETY AND HEALTH CONSIDERATIONS

Before opening tank be sure that it is not pressurized. Be sure that the gauge reads "0 PSI". Depressurize the tank before opening it by exhausting pressure through the abrasive gun (#24).

Disconnect the air compressor before opening tank.

Protect yourself and those around you from "overspray". Remember that your portable abrasive blaster is shooting a powerful spray of abrasive material. Do not point it at yourself or anyone around you.

Wear a filter or mask over your mouth when using this unit. You will create a cloud of abrasive material and debris which is dangerous to inhale.

Remove cover or protect anything around you that might be damaged from direct or indirect contact with the abrasive spray or particles. Anything subject to contamination damage (computers, electronics, etc) or anything with a fine surface (automobiles, furniture, etc.) should NOT be near your pressure blaster.

### CAUTION:

1. Pay particular attention to the abrasive hose (#21), abrasive gun (#24) as they will wear out much more quickly than others pieces.
2. The abrasive hose needs replacing when its side walls develop leaks or show blisters in the surface. Do not use if any of these problem are present.

### SPECIFICATIONS:

Model:	ATD-8401
Tank Volume:	5 Gallon
Hose Length:	8 Feet
Working Pressure	60-125PSI
Air Consumption:	6-25CFM
Overall Dimensions:	L:18.89" x W: 11.42" x H:32.68"
Weight:	27lbs



## TROUBLESHOOTING

PROBLEM	REMEDY
<b>Surging of blast flow?</b> Air pressure too low Too much media	See "Lack of Air" Adjust media valve
<b>Excessive media consumption?</b> Media valve open too far Air pressure too low	Close slightly Check pressure gauge
<b>Clogging and plugging of blast flow?</b> Debris in media Media size too large Nozzle plugs Wet media	Purge & Screen Use smaller grit size Use large nozzle or Adjust media valve Dry media, drain water from air
<b>Moisture in abrasive media?</b> Wet media Water in air Water in tank	Change or use dry media Drain water from air lines Empty, dry out and refill
<b>Humid weather?</b> Moderate humidity Moderate humidity High humidity	Keep media dry as possible Use drier or moisture separator Avoid that period of use if possible
<b>Overtaxed compressor?</b> Compressor too small Nozzle size too large Too many leaks in air lines Holes in abrasive hose Air filter on compressor plugged	Restrict time used Use smaller size Seal & tighten air lines Replace hose Clean filter
<b>Lack of air pressure?</b> Compressor too small Supply valves not on full position Nozzle size too large Leaks in air lines Holes in abrasive hose Air filter on compressor plugged Urethane gasket worn or dirty	Use smaller nozzle Open valves Use smaller size Seal & tighten air lines Replace hose Clean filter Clean or replace gasket
<b>Lack of abrasive flow?</b> Blaster tank empty Moisture in media Not enough air pressure Abrasive hose kinked Debris in media	Fill tank Dry media Check system Straighten Clean or screen media



# ATD-8401

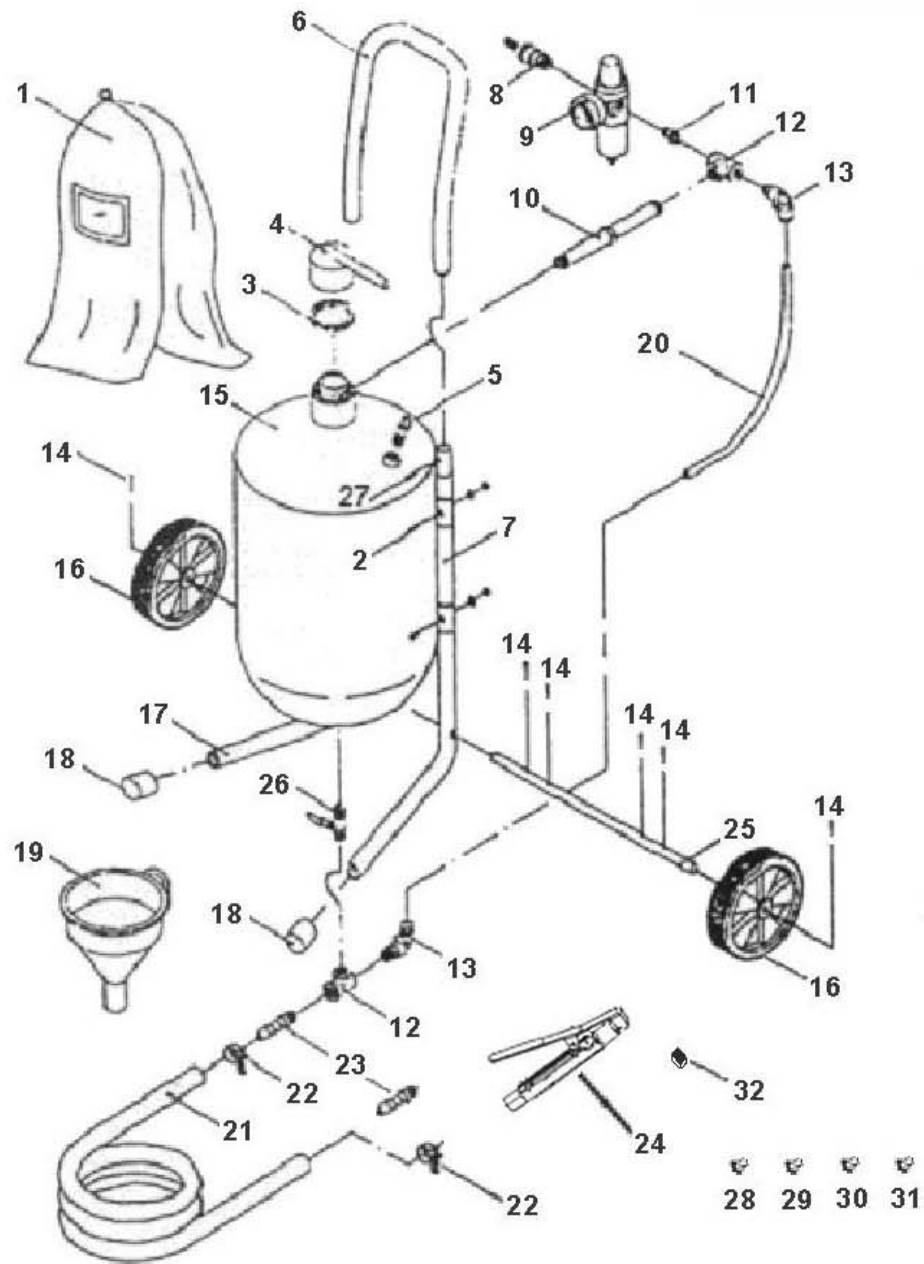

<b>ITEM#</b>	<b>ORDERING PART#</b>	<b>PART DESCRIPTION</b>
01	PRT8401-01	HOOD
02	PRT8401-02	SCREW
03	PRT8401-03	O-RING
04	PRT8401-04	TANK FILLER CAP
05	PRT8401-05	SAFETY VALVE
06	PRT8401-06	HANDLE BAR
07	PRT8401-07	LEFT LEG
08	PRT8401-08	CONNECTOR
09	PRT8401-09	AIR PRESSURE ADJUSTER
10	PRT8401-10	JOINT PIPE
11	PRT8401-11	NIPPLE CONNECTOR
12	PRT8401-12	INTAKE MANIFOLD
13	PRT8401-13	ELBOW CONNECTOR
14	PRT8401-14	COTTER PIN
15	PRT8401-15	TANK
16	PRT5200-21	WHEEL
17	PRT8401-17	RIGHT LEG
18	PRT8401-18	LEG END CAP
19	PRT8401-19	FUNNEL
20	PRT8401-20	AIR HOSE
21	PRT8401-21	ABRASIVE HOSE
22	PRT8401-22	HOSE CLAMP
23	PRT8401-23	HOSE ADAPTOR
24	PRT8401-24	ABRASIVE GUN
25	PRT8401-25	AXLE
26	PRT8401-26	ABRASIVE METERING VALVE
27	PRT8401-27	SELF-TAPPING SCREW
28	PRT8401-28	NOZZLE, 2.0mm
29	PRT8401-29	NOZZLE, 2.5mm
30	PRT8401-30	NOZZLE, 3.0mm
31	PRT8401-31	NOZZLE, 3.5mm
32	PRT8401-32	RUBBER PAD (SHUT OFF BLOCK)