



ATD-5835

HEAVY DUTY 13" HAND RIVETER



Features

- Patented structure increases power and reduces shock.
- Shortest long arm riveter that can operate up to 1/4" (6.4mm) stainless steel rivets.
- Shorter handle with double compound hinges that maximize leverage.
- Ideal for working in hard-to-reach areas.
- 3 piece, Cr-Mo steel jaws provides long lasting tool life
- One-piece collet case eliminates the need to adjust the tool when changing rivet diameters.
- Core collection bottle for safety and ease of disposal.
- Ergonomic grip for easy operation.

Specifications

- 5 Nosepieces: 1/8" (3.2mm), 5/32" (4.0mm), 3/16" (4.8mm), 7/32" (6.0mm) and 1/4" (6.4mm).
- Length: 12-9/16" (320mm)
- Weight: 2.5lbs (1.14kg)

Important Safety Instructions

1. Read all instructions before using this unit.
2. Always wear ANSI approved safety goggles when using this product.
3. Normal use of this product is likely to expose the user to dust and/or microscopic particles containing chemicals known to the State of California to cause cancer, birth defects or other reproductive harm
4. Always wear appropriate safety equipment and clothing when using this product. Study, understand, and follow all instructions provided with this product.

Warning: Wear safety glasses.

Instructions for Use:

1. Open tool handle fully and insert rivet mandrel all the way into tool nosepiece then insert rivet head completely into the prepared hole.
2. Squeeze tool handle until rivet mandrel breaks off. If more than one squeeze is required, open tool handle fully and squeeze again.
3. Finally, open tool handle fully to eject rivet mandrel from tool into the core collection bottle.

ATD

ATD-5835

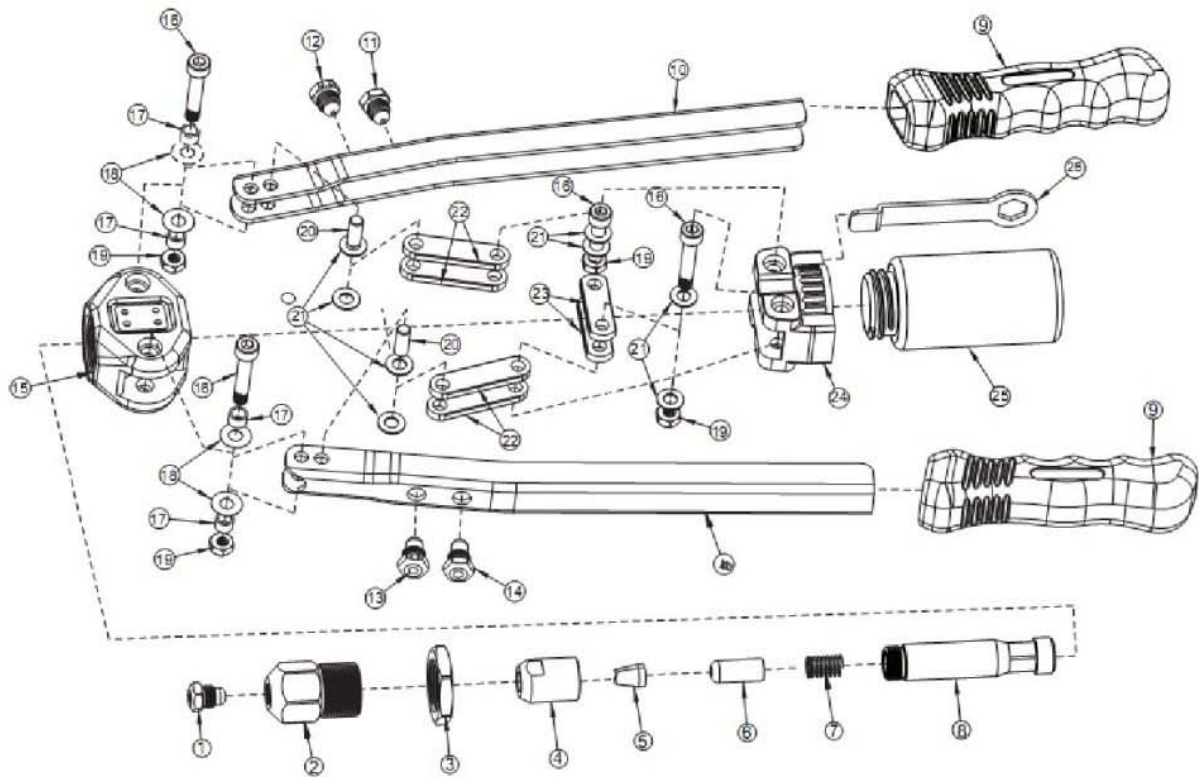

ITEM#	ORDERING PART#	PART DESCRIPTION
1	PRT5835-01*	NOSEPIECE 3/16"(4.8MM)
2	PRT5835-02*	OUTER CYLINDER
3	PRT5835-03*	LOCK NUT
4	PRT5835-04*	JAW CARRIER
5	PRT5835-05*	JAW
6	PRT5835-06*	JAW PUSHER
7	PRT5835-07*	SPRING
8	PRT5835-08*	PULLING BAR
9	PRT5835-09	GRIP
10	PRT5835-10	HANDLE
11	PRT5835-11*	NOSEPIECE 5/32"(4.0MM)
12	PRT5835-12*	NOSEPIECE 1/8"(3.2MM)
13	PRT5835-13*	NOSEPIECE 7/32"(6.0MM)

ITEM#	ORDERING PART#	PART DESCRIPTION
14	PRT5835-14*	NOSEPIECE 1/4"(6.4MM)
15	PRT5835-15	ALUMINUM BODY
16	PRT5835-16	SCREW
17	PRT5835-17	SCREW WASHER
18	PRT5835-18	STAINLESS WASHER
19	PRT5835-19	NUT
20	PRT5835-20	PIN
21	PRT5835-21	WASHER
22	PRT5835-22	LINKS
23	PRT5835-23	METAL FIXTURE
24	PRT5835-24	CORE COLLECTOR BASE
25	PRT5835-25*	CORE COLLECTOR BOTTLE
26	PRT5835-26*	WRENCH

Note: Only the parts with asterisk (*) are available for replacement.