



ATD-5578

# FUEL INJECTION TEST SET MANUAL



Made in China to ATD Tools, Inc. Specifications  
Visit us at [www.atdtools.com](http://www.atdtools.com)



## IMPORTANT PRE-TEST INFORMATION

### Safety Precautions

1. Do not smoke when working on fuel systems.
2. Never work on fuel systems where a flame or spark could be present. Keep a dry chemical fire extinguisher near you.
3. Wear safety glasses at all times.
4. Clean all connections, and keep dirt out of the system.
5. To avoid fuel spray, wrap a shop towel around the pressure tap fittings when connecting and disconnecting adapters.
6. Provide for proper ventilation of gasoline and exhaust fumes.
7. If a leak or spill develops, turn off ignition, disable fuel pump and clean up any spills immediately.
8. Operators must read and follow the operating instructions from a reliable shop manual for proper test procedures, access points, and pressure specifications.

### Pretest System Checks

#### 1. Fuel System

Look for broken or loose fuel lines

Check for water or other contaminants in the fuel, and make sure fuel tank has sufficient fuel for testing.

Check condition of fuel tank venting systems, fuel tank filler cap, and fuel systems related fuses.

#### 2. Electrical System

Check conditions of all electrical systems and other computer fault indicators.

If engine won't start, check for ignition spark using a test plug.

#### 3. Battery & Charging System

Check battery condition, make sure battery is fully charged

Check for loose or corroded battery cables.

#### 4. Miscellaneous

Check for loose or disconnected vacuum lines.

Check for water or oil leaks.

Check for any audible air leaks, unusual noises, fuel pump buzz, engine rattles or knocks.

Check valve timing and adjustment.



## BASIC FUEL PRESSURE DIAGNOSIS

Fuel injected engines require precise fuel pressure as well as adequate volume. Without the correct pressure and volume, performance and fuel economy can suffer. Always consult the correct repair manual for accurate specifications.

Fuel pressure problems generally fall into two categories: higher than normal and lower than normal operating pressures. When running tests, it may help to picture the fuel system as a circle. Fuel is pumped from the tank to the fuel regulator and injectors, and the unused fuel is then returned to the tank. The fuel regulator serves as a divider between the supply side and return side. A higher than normal pressure is generally caused by a malfunction in the return side, and a lower than normal pressure is generally caused by a problem in the supply side.

Higher than normal pressures can usually be attributed to faults such as:

1. Defective fuel pressure regulator
2. A damaged or restricted fuel line
3. Excessive tank pressure caused by a poor vent system

Lower than normal pressures can usually be attributed to faults such as:

1. Clogged fuel filter
2. A damaged or restricted fuel line
3. Defective fuel pump
4. Defective pressure regulator
5. Clogged fuel filter sock in tank
6. Low pressure in tank (vacuum) caused by improper venting

## Trouble Shooting Multi-port & TBI Systems

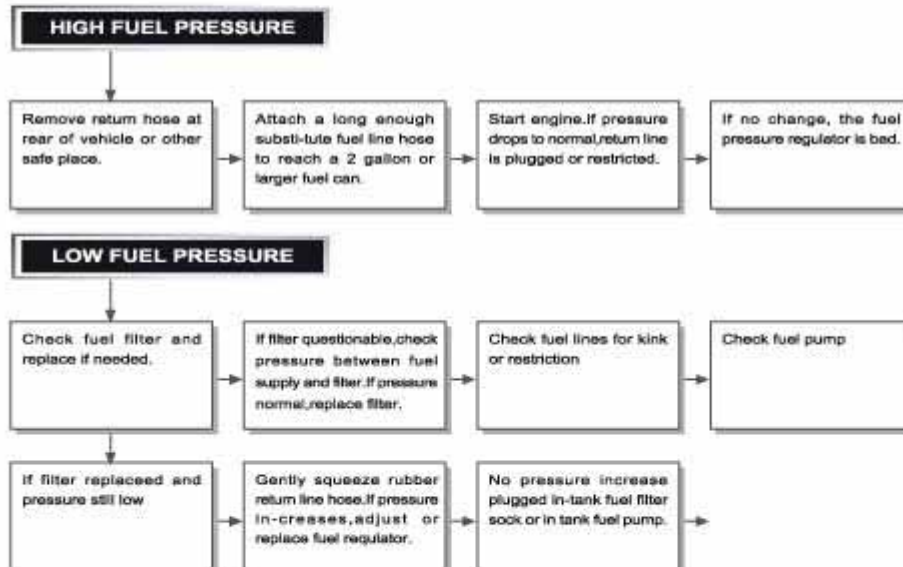



## FUEL INJECTION TEST SET MANUAL

### PROCEDURE TO RELIEVE FUEL SYSTEM PRESSURE

High fuel pressure may be present in fuel lines and components. Unless a Schrader Valve test port is available, most manufacturers require that you relieve the fuel pressure before entering or leaving the system. Follow the instructions below to relieve fuel system.

1. Remove gas cap with ignition off
2. Unplug or disconnect at fuel pumps. On some vehicles may have two fuel pumps, in tank and outside, make sure both are disabled. Also on some vehicles, such as Audi, BMW, Ford, GM, Mazda, and Mercedes-Benz, another disabling method must be used. (see Fuel Pressure Release Chart Below).
3. Turn the ignition key on and start the engine.
4. Run the engine until it stalls.
5. Crank starter for 3-5 seconds to remove remaining fuel from the fuel lines. For cars with inertia switch pressure relief, engage starter 15 seconds to relive fuel pressure.
6. Turn ignition key off

#### Fuel Pressure Release Unplug or disconnect at fuel pump(s)

Acura	Geo	Nissan/Datsun	Subaru
Alfa Romeo	Honda	Peugeot	Suzuki
AMC	Hyundai	Porsche*	Toyota
Chrysler	Isuzu	Renault	Triumph
Daihatsu	Jaguar	Saabr	Volkswagen*
Eagle	Jeep	Sterling	Volvo*
Fiat	Mitsubishi		

*\*some models have two fuel pumps, in tank and outside. Unplug both.*

#### Disable in other ways:

##### **Audi**

Coupe & Quattro : unplug fuel pump connector. All others : remove fuel pump relay.

##### **BMW**

Through 1990 : Disconnect negative terminal of fuel pump.  
1991:Unplug fuel pump connector.

##### **Ford**

Cars, vans, and utility vehicles except Explorer: Disconnect Inertia seitch.

Explorer: Unplug fuel pump connector.

Some Ford products have two fuel pumps. It is important that both fuel pumps are disabled.

##### **GM**

All except below:unplug fuel pump connector.

(a)1975-80 Cadillac: Disconnect one fuel pump in gas tank and second one on chassis, left front of tank;

(b)1986-89 Corvette: Remove fuel pump fuse if one fuel pump.If two fuel pumps, remove the correct 10 amp. fuse in both the main and auxiliary fuse blocks.

##### **Mazda**

MPV,MX-6,626,RX7,323,929, & Navajo: Unplug freil pump connector.

B2600,MX5, & Miata:Disconnect circuit opening relay connector.

##### **Mercedes-Benz**

Disconnect negative terminal of fuel pump connector.



## FUEL INJECTION TEST SET MANUAL

### TYPICAL FUEL INJECTION PRESSURE TEST

(For Bosch CIS & GM TBI, see additional instructions)

1. With engine off, locate fuel pressure port and simply connect the proper adapter to the gauge assembly, thread the adapter to the test port. If no pressure port is provided, the system must be opened. Residual pressure must be released before disconnecting any components. See **"PROCEDURE TO RELIEVE FUEL SYSTEM PRESSURE"** and follow instructions. Connect tester using the correct adapter and access point. Always wrap a shop towel around fitting before loosings.
2. With gauge connected into system using proper adapters, reactivate fuel pump, turn ignition on and engine off, and check for leaks. If no leaks are detected, observe gauge. Pressure should rise slightly above operating pressure and then stabilize at operating pressure.
3. Start engine. If an adjustable fuel pressure regulator is used, pressure should be maintained during running. If a compensating fuel pressure regulator is used, pressure should drop approximately 3-10 PSI, depending on manifold vacuum.
4. If the fuel pressure is not within specifications, refer to the **"BASIC FUEL PRESSURE DIAGNOSIS"** and **"TROUBLE SHOOTING CHART"**.
5. If pressures are acceptable, some manufacturers also require a flow test. If so, at this point open the fuel system into a graduated plastic container and observe flow rate.
6. Turn key off and observe residual pressure. Some manufacturers prescribe a minimum holding time.
7. In conjunction with an injector pulse tester, turn key on, observe pressure, pulse one injector, observe pressure drop, turn key off, continue with remaining injectors. Caution: Do not repeat this test more than manufacturer's recommendations. Flooding of engine may occur.
8. Deactivate fuel pump and relieve fuel system if necessary. With key off, put bleed-off tubing in a fuel can and press bleed-valve.
9. Remove tester and reconnect all lines
10. Start engine and check for leaks.

### Typical Multi-port Fuel Injection System With Schrader Valve

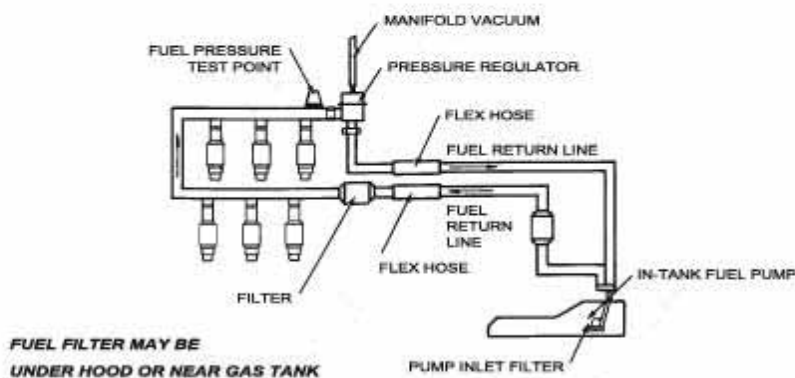



### ADDITIONAL INSTRUCTIONS GM TBI PRESSURE TEST

1. Relieve fuel system pressure, refer to the "PROCEDURE TO RELIEVE FUEL SYSTEM PRESSURE".
2. Remove the air cleaner assembly
3. Temporarily plug the thermal vacuum port on the throttle body. When removing fuel line, always use 2 wrenches to prevent damage. Install fuel pressure gauge and adapter in fuel between steel line and flexible hose.
4. Reactivate fuel pump, start the engine and check for leaks.
5. When fuel pressure has stabilized after a minute or so, gauge should read 9-13 PSI
6. If the fuel pressure is not within specifications, refer to the "BASIC FUEL PRESSURE DIAGNOSIS" and "TROUBLE SHOOTING CHART".
7. Deactivate fuel pump, and relieve fuel system pressure. With key off, put bleed-off tubing in a fuel can and press bleed-off valve.
8. Remove tester and reconnect all lines.
9. Start Engine and check for leaks.
10. Remove fuel from all tester hoses.

### Typical TBI Fuel Injection System

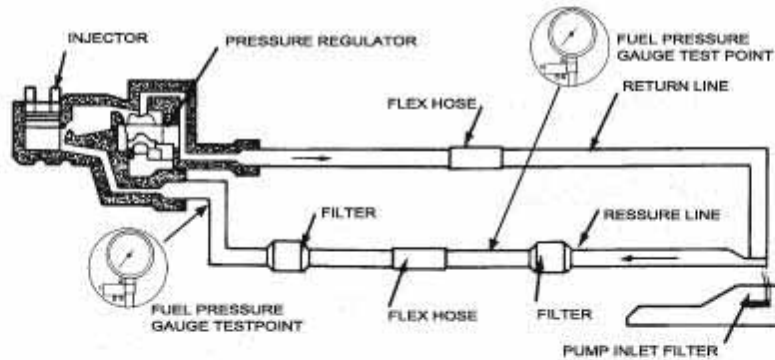

POSITION OF FILTER MAY VARY



## ADDITIONAL INSTRUCTIONS FOR BOSCH CIS PRESSURE TEST

Note: Control pressure is measured with valve open system pressure is measured with valve close.

1. Relieve fuel system pressure, refer to the "PROCEDURE TO RELIEVE FUEL SYSTEM PRESSURE".
2. Make sure fuel filter is not clogged. Replace if doubtful.
3. Clean dirt off the fuel distributor top
4. Install fuel pressure gauge and adapter between the fuel distributor test port and flow control valve. Ensure control lever is in the closed position. Bleed excess air from system by cycling control valve with gauge upside down.
5. Using a jumper wire, connect terminal No. 30 and 87 on fuel pump relay. Open fuel pressure gauge control lever. Fuel pressure should be within specification.
6. If fuel pressure is too low, perform fuel pump volume check. Also, there may be a blockage in the supply line or leakage in the return line. If fuel volume is okay, the fuel system pressure needs adjustment or replace fuel pressure regulator.
7. If fuel pressure is above specification, remove return hose from pressure regulator and repeat test. If fuel pressure is within specification, check for restricted fuel return line. If pressure is incorrect, the fuel system pressure needs adjustment or replace fuel pressure regulator.
8. Deactivate fuel pump, and relieve fuel system pressure. With key off, put bleed-off tubing in a fuel can and press bleed-off valve.
9. Remove tester and reconnect all lines.
10. Start Engine and check for leaks.
11. Remove fuel from all tester hoses.

### Typical C.I.S Pressure Testing Fuel Injection Hookup

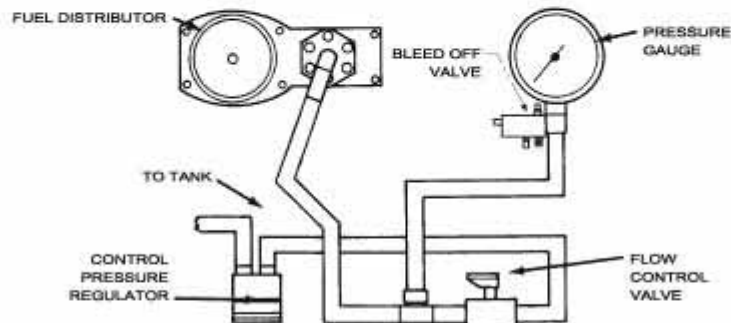



## FUEL INJECTION TEST SET MANUAL

### FUEL INJECTION PARTS & TEST PORT ADAPTERS



A— 3 1/2" Gauge Head with dual readings—0-145 psi & 0-1000 KPA(10Bar). Can be used for all tests.



AE— Low pressure 2-1/2" gauge with dual readings—0-15 psi & 0-1 kg/cm<sup>2</sup>(1 Bar). Use for tests where an accurate reading below 15 psi is required.



D— Gauge Hose assembly with blow-down valve. Can be used on all tests between the gauge and adapters. Provides a clean and convenient method of relieving pressure after testing, or for a retest. Can also be used for observing steadiness and volume of fuel. Simply put end of clear tubing into proper container and push the side button.



G— CIS/TBI Test Hose - use when testing CIS or TBI Systems where in line connections are needed. Includes shut-off valve for both control & primary system pressure checks. We recommend that the D Gauge Hose is used with CIS testing, as most manufacturers require that all air be purged from the tester when running tests.



C— Small schrader type test hose with .308 x32 thread. Common applications—Ford EFI.



B— Large schrader type test hose with 7/16 x20 thread. Common applications include Chrysler, Jeep, and GM Test Port.





## FUEL INJECTION TEST SET MANUAL

### FUEL INJECTION PARTS & TEST PORT ADAPTERS

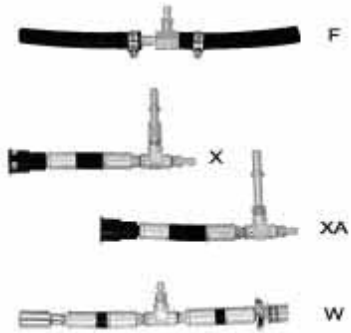

**F**— Double Ended Barb Fitting-Common Application-Where 5/16-3/8 fuel line hose can be entered for testing-AMC,Chrysler,w/TBI,Flat,GM w/Bosch L-Jetr,Jaguar,Mazda,Nissan,Puegot & Porsche w/Bosch L-Jetr,Rensault,Subaru,Triumph,and VW & Volvo w/Bosch L-Jetr.

**X**— Hair Pin Hose 5/16"-Common Application-Ford EFI

**XA**- Hair Pin Hose 3/8"-Common Application-GM Chrysler

**W**—Spring Lock Hose -Common Application-Ford EFI



**E**— Single End Hose Connection 1/4" X3/8"-Common Applications-older Port Systems with hose connection, and where rubber hose fuel lines from 1/4"-3/8" can be accessed.

**MCA** - 430 Male Quick Disconnect Fitting, Common Application - Mitsubishi, Chrysler

**MA**- 5/8" Male Quick Disconnect Fitting, Common Application - Mitsubishi

*Tbi In Line Testing Adapters,  
Common Applications  
- Gm Tbi Systems*



**V**— 5/8" x 18" Male fitting(2 pc.)

**U**— 16mm x 1.5 Male Tube nut(2)

**T**— 16mm x 1.5 Male Tube nut(2)

**UB**- 14mm x 1.5 Male Tube nut(2)

**UA**- 14mm x 1.5 Male Tube nut(2)

**UC**- 14mm x 1.5 Plug

**S**— Union-5/8" x18



## FUEL INJECTION TEST SET MANUAL

### FUEL INJECTION PARTS & TEST PORT ADAPTERS

*End Of Line Fuel Bolt Adapters,  
Common Applications-accura,  
Honda,Hyundai,  
Mazda,Suzuki,Toyota.*

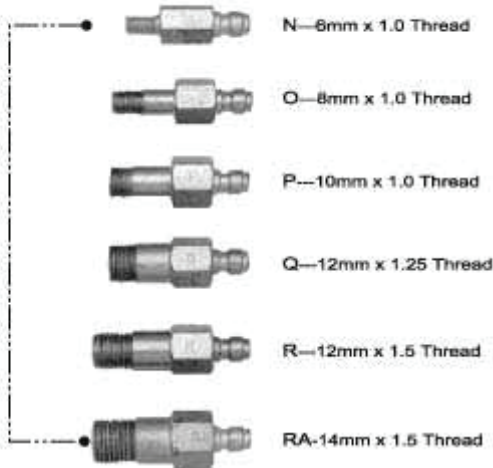

*In Line Testing Cis,  
Cise, & K-jetronic Adapters,  
Common Applications-audi,  
Bmw,Mercedes,Puegot,  
Porsche,Saab,Vw,  
Volvo W/Cis,Cise,  
Or K-jetronic Systems.*

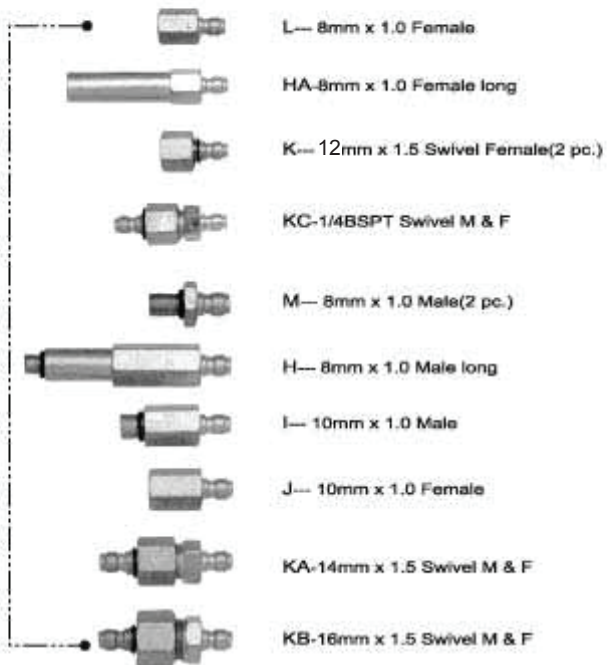

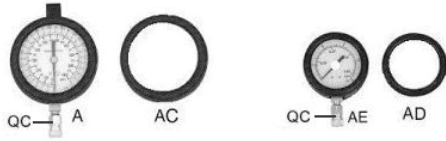

# ATD-5578

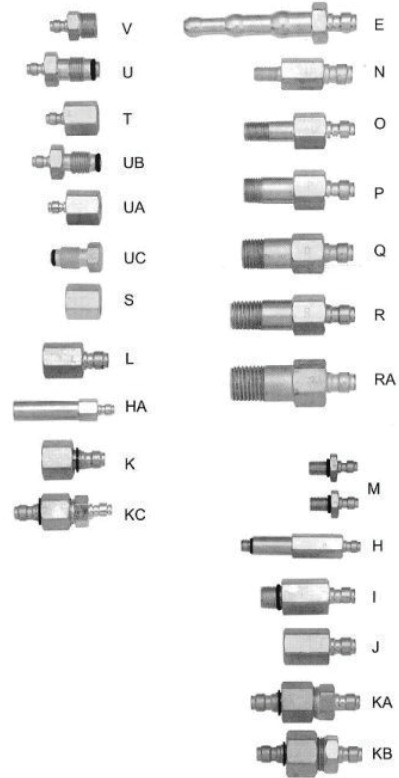
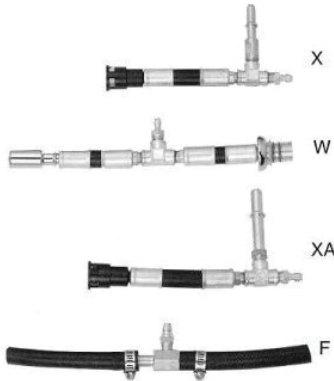
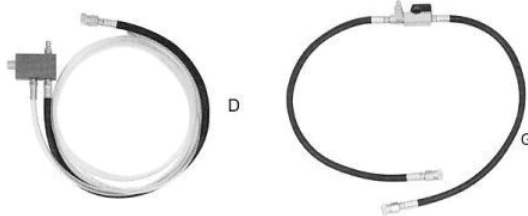

ITEM#	ORDERING PART#	PART DESCRIPTION
A	PRT5578-A	3.5" GAUGE W/QUICK COUPLER
AC	PRT5578-AC	3.5" GAUGE PROTECTOR
AD	PRT5578-AD	2.5" GAUGE PROTECTOR
AE	PRT5578-AE	2.5" GAUGE W/QUICK COUPLER
B	PRT5578-B	7/16" x 20 ADAPTER HOSE GM / CHRYSLER
N/S	PRT5578-B-HS	RED SEAL FOR "B" HOSE VALVE
C	PRT5578-C	308 x 32 ADAPTER HOSE FORD EFI
D	PRT5578-D	GAUGE HOSE WITH RELIEF VALVE
E	PRT5578-E	SINGLE END HOSE ADAPTER
F	PRT5578-F	DOUBLE END HOSE ADAPTER 5/16" - 3/8"
G	PRT5578-G	CIS/TBI HOSE ASSY W/VALVE
H	PRT5578-H	8MM x 1.0 MALE CIS FITTING (LONG)
HA	PRT5578-HA	8MM x 1.0 FEMALE CIS FITTING (LONG)
I	PRT5578-I	10MM x 1.0 MALE CIS FITTING
IM	PRT5578-IM	INSTRUCTION MANUAL
J	PRT5578-J	10MM x 1.0 FEMALE CIS FITTING
K	PRT5578-K	12MM x 1.5 FEMALE CIS SWIVEL FITTING
KA	PRT5578-KA	14MM x 1.5 SWIVEL FITTING MALE & FEMALE
KB	PRT5578-KB	16MM SWIVEL FITTING MALE & FEMALE
KC	PRT5578-KC	1/4" BSPT SWIVEL FITTING MALE & FEMALE
L	PRT5578-L	8MM x 1.0 FEMALE CIS FITTING

ITEM#	ORDERING PART#	PART DESCRIPTION
M	PRT5578-M	8MM x 1.0 MALE CIS FITTING
MA	PRT5578-MA	430 MALE QUICK DISCONNECT - MITS/CHRY
MCA	PRT5578-MCA	5/8" MALE QUICK DISCONNECT - MITSUBISHI
N	PRT5578-N	6MM x 1.0 BANJO FITTING
O	PRT5578-O	8MM x 1.0 BANJO FITTING
P	PRT5578-P	10MM x 1.0 BANJO FITTING
Q	PRT5578-Q	12MM x 1.25 BANJO FITTING
QC	PRT5578-QC	QUICK COUPLER FOR GAUGES
R	PRT5578-R	12MM x 1.5 BANJO FITTING
RA	PRT5578-RA	14MM x 1.5 BANJO FITTING
RK	PRT5578-RK	REPAIR KIT (RUBBER SEALS/BRASS)
S	PRT5578-S	5/8" x 18 UNION
T	PRT5578-T	16MM x 1.5 FEMALE TUBE ADAPTER
U	PRT5578-U	16MM x 1.5 MALE TUBE ADAPTER
UA	PRT5578-UA	14MM x 1.5 FEMALE TUBE ADAPTER
UB	PRT5578-UB	14MM x 1.5 MALE TUBE ADAPTER
UC	PRT5578-UC	14MM x 1.5 MALE PLUG
V	PRT5578-V	5/8" x 18 MALE FITTING
W	PRT5578-W	FORD SPRING LOCK HOSE
X	PRT5578-X	FORD HAIR PIN HOSE 5/16"
XA	PRT5578-XA	GM/CHRYSLER HAIR PIN HOSE 3/8"