



# ATD-5483 Master In-Line Flaring Tool Kit

## INSTRUCTIONS FOR IN LINE DOUBLE FLARING

1. Make sure tubing is cut off square and burrs removed.
2. Chamfer outside of tubing with either a file or grinding wheel.
3. Insert tubing through two sides of clamping base using included adapter as guide for proper length.
4. Alternate tightening the two cap screws of the clamping base to grip the tubing. Too loose a grip will allow the tubing to push through.
5. Insert stem of adapter into end of tubing. (See Diagram 1) Place hex yoke over flaring adapter and hand tighten on to clamping base. (Do not use wrench to tighten) (See Diagram 2)
6. Thread flaring screw into Hex yoke. Screw until tight and firm which will produce the first flare. This will form a bell shape in tubing. (See Diagram 3)
7. Un-thread screw until loose.
8. Un-thread Hex yoke completely and remove adapter. Check for proper bell shape.
9. Replace Hex yoke and tighten to base.
10. Thread screw into hex yoke again until completely tight. This should complete the double flare.

## INSTRUCTIONS FOR IN LINE BUBBLE FLARING

1. Make sure tubing is cut off square and burrs removed.
2. Chamfer outside of tubing with either file or belt sander/grinding wheel.
3. Insert tubing through the two sides of the clamping base using included adapter as guide for proper length and position. (See diagram 1)
4. Alternate tightening the two cap screws of the clamping base to grip the tubing. Tighten sufficiently to hold tubing in place.
5. Insert stem of adapter into end of tubing. (Diagram 1). Place hex yoke over flaring adapter and hand tighten on to clamping base. (Do not use wrench to tighten). (See diagram 2)
6. Thread flaring screw into hex yoke. Screw until tight and firm which will produce the bubble flare. The flare should look like a bell shape. (Diagram 3)
7. Un-thread screw until loose. Remove hex yoke and adapter.
8. Un-tighten and remove the tubing, completing the bubble flare operation.

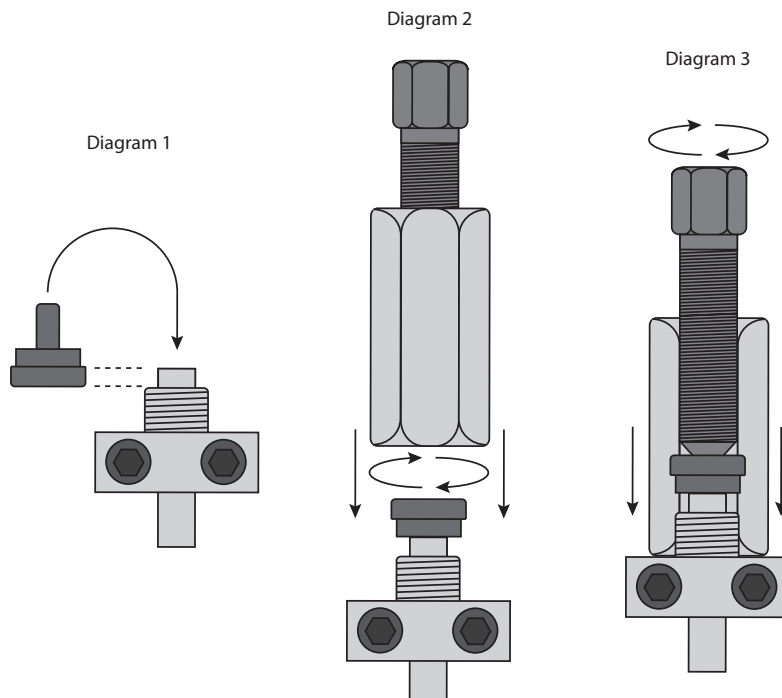



# ATD-5483

## MASTER IN-LINE FLARING TOOL KIT

### Parts Listing

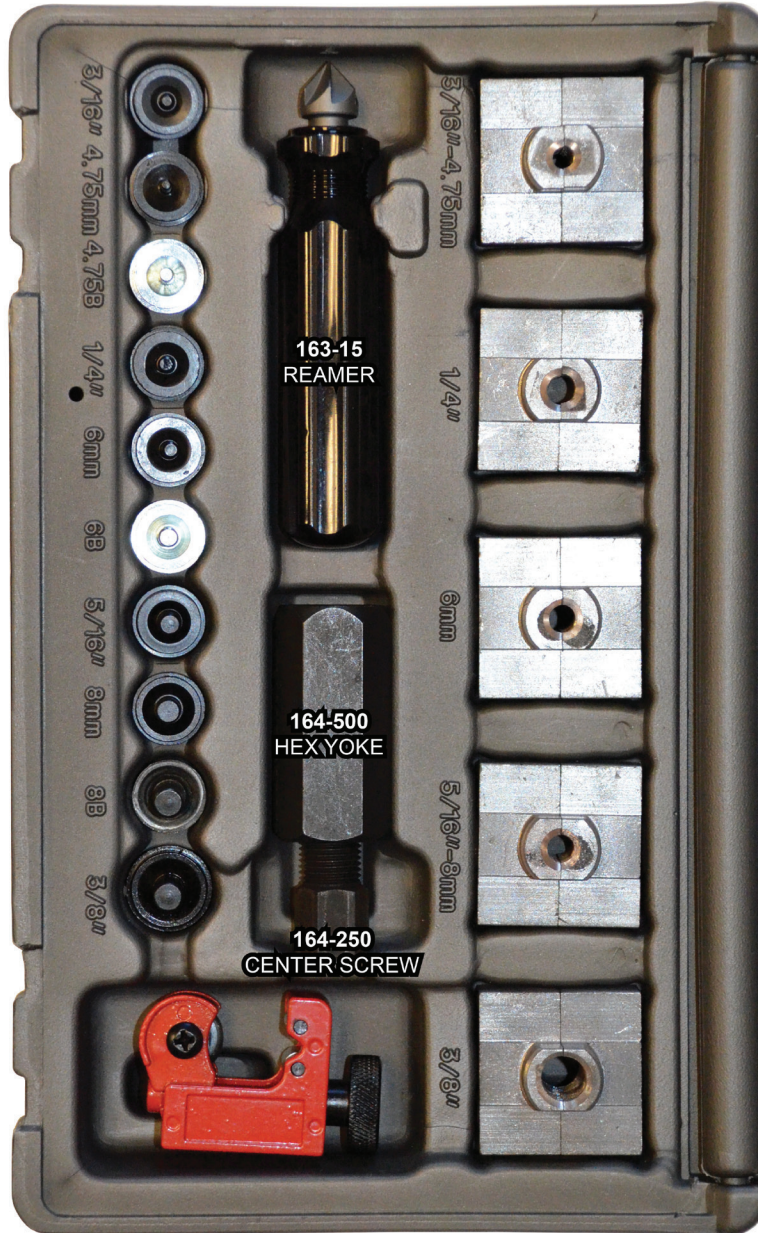

- 163-3A**  
3/16 ADAPTER
- 163-23**  
4.75MM ADAPTER
- 155-3**  
4.75MM INLINE BUBBLE ADAPTER
- 163-4A**  
1/4 ADAPTER
- 163-25**  
6MM ADAPTER
- 155-4**  
6MM INLINE BUBBLE ADAPTER
- 163-5**  
5/16" ADAPTER
- 163-26**  
8MM ADAPTER
- 155-5**  
8MM BUBBLE FLARE ADAPTER
- 163-8A**  
3/8" ADAPTER
- 151**  
Mini Tubing Cutter

- 164-100KIT**  
3/16" - 4.75MM FLARING BAR CLAMP
- 165-100KIT**  
1/4" FLARING BAR CLAMP
- 166-100KIT**  
6MM FLARING BAR CLAMP
- 168-100KIT**  
5/16" - 8MM FLARING BAR CLAMP
- 169-100KIT**  
3/8" FLARING BAR CLAMP