



ATD-3715 / ATD-3716 AUTO-DARKENING WELDING HELMET INSTRUCTIONS



ATD-3715



ATD-3716

Specifications:

- Viewing Field – 3.62" x 1.61" (92 x 41mm)
- Shade Control – Light States: DIN 4
Dark States: DIN 9 – 13 outside adjustment
- Switching Time – Light - Dark: 0.6 ms
- Delay Time - Dark - Light: 0.1 – 0.8 sec
- Sensitivity & Delay Time - Stepless adjustment
- UV/IR Protection - Up to Shade DIN16
- Operating Temperature – 23°F to 131°F (-5°C to + 55°C)
- Power Supply - Solar Cells & Integral Lithium Batteries
- Lens Control - Auto-on, Auto-off 15 minutes (when not on welding)
- Standards - CE : EN379:2009; EN175:1997
- Helmet Material - PP (Fireproofing)
- Total Weight – 1.05 lbs. (480g)

General Safety Warnings:

 **WARNING:** The instructions and warnings contained in this manual should be read and understood before using or operating this tool. Do not allow anyone to use or operate this helmet until they have read this manual and have developed a thorough understanding of how this helmet works. Failure to observe any of the following instructions could result in severe personal injury to tool user and bystanders, or cause damage to the helmet and/or property. Keep this manual for future reference.





Note: The warnings and cautions discussed in this instruction manual cannot cover all possible conditions and situations that may occur. It must be understood by the operator that common sense and caution are factors which cannot be built into this product, but must be supplied by the operator.

 **WARNING:** DO NOT USE the welding helmet if the lens is cracked, if the lens or sensors are dirty, or if the lens or retaining frames are loose.

 **WARNING:** Use safety equipment. When welding, users and bystanders should wear ANSI-approved impact safety goggles under the welding helmet. Wear a NIOSH-approved respirator and hearing protection when welding. Use an ANSI approved dust mask or respirator when working around metal, wood, and chemical dusts and mists. This applies to all persons in the work area. Also use non-skid safety shoes, hardhat, gloves, dust collection systems, and hearing protection when appropriate.

 **WARNING:** Keep bystanders and children out of the work area while operating this tool.

 **WARNING:** Always keep your work area clean, uncluttered, and well lit. Cluttered or dark areas invite accidents and injuries. DO NOT work on floor surfaces that are slippery.

 **WARNING:** Do not operate this tool if you are tired or under the influence of alcohol, drugs, or medications that could affect your ability to use the tool properly.

 **WARNING:** Dress properly. Do not wear loose clothing or jewelry as they can be caught in moving parts. Wear restrictive hair covering to contain long hair.

 **WARNING:** Do not reach over or across running machines. Keep proper footing and balance at all times. Non-skid footwear is recommended when working.

 **WARNING:** Check for damaged parts. When servicing, use only identical ATD replacement parts. Use of any other parts can render helmet ineffective, possibly causing eye damage, and will void the warranty.

ASSEMBLY INSTRUCTIONS:

1. Parts included in this package include the following:
 - Welding Shield with auto-darkening lens
 - Headgear assembly
 - Instructions

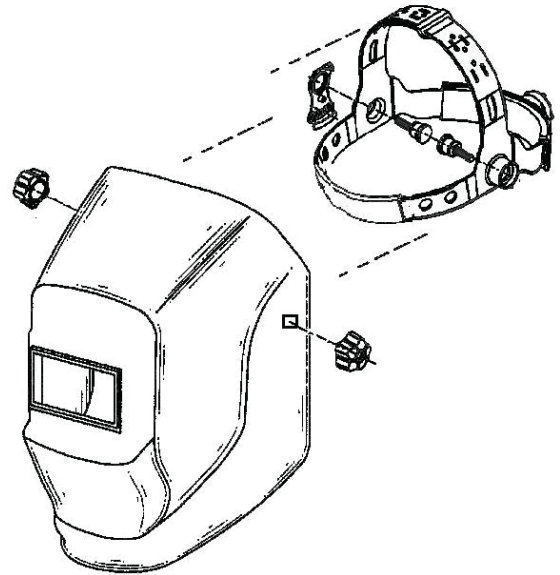

2. Install headgear by removing threaded knobs (one at a time) and fasten again after placing each threaded stud through the larger holes on the sides of the helmet. Push in and rotate the adjustment knob at the rear of the headgear assembly to fit the users head.

WARNING:

- Welding Helmets do not provide unlimited eye, ear and face protection.
- This Auto-Darkening Helmet is not suitable for laser or oxyacetylene welding.
- Do not use this welding helmet while working with or around explosive or corrosive liquids.
- Never place this Helmet and Auto-Darkening filter on a hot surface.
- Inspect the auto-lens frequently. Immediately replace any scratched, cracked, or pitted cover lenses or auto-lenses.

REPLACING THE PROTECTION LENS:

- Ensure that the helmet is always fitted with an outer and inner protection lens
- These protection lenses must be replaced if broken, damaged or covered with welding spatter to the extent that vision is impaired.
- Outer and inner protection lenses are consumables and must be replaced regularly with genuine certified spare parts.

OPERATING INSTRUCTIONS:

1. Before using this welding helmet for the first time the protective film that covers the protection lenses must be removed from both sides of the lens.
2. Before welding, the window will be in light DIN 4 state and you can see the work piece. The lens will automatically darken when an arc is struck. **BEFORE STRIKING AN ARC ON THE WORK PIECE, TEST THE LENS BY STRIKING A MATCH OR A LIGHTER. DO NOT USE IF THE LENS IS NOT OPERATING PROPERLY.**

3. Change dark shade between 9 and 13 as desired by using the variable adjustment knob. Refer to Table 1 below if necessary.



4. Adjust the Sensitivity and Delay Time as desired by using the variable adjustment Knob



5. When helmet is not used for 15 minutes the power will automatically shut-off. There is no OFF switch.

SHADE GUIDE TABLE

(as per EN 169 and BS 379)

Welding Process	Arc Current (Amperes)																		
	10	20	30	40	60	80	100	125	150	175	200	225	250	275	300	350	400	450	500
SMAW		9			10		11			12			13			14			
MIG (heavy)					10		11		12			13			14				
MIG (light)					10		11		12		13		14		15				
TIG, GTAW	9	10	11		12		13		14										
MAG/CO2				10		11	12	13			14		15						
SAW								10	11	12	13	14	15						
PAC					11			12		13									
PAW	9	10	11	12		13			14			15							

NOTE:

- SMAW – Shielded Metal Arc Welding
- SAW – Shielded Semi – Automatic Welding
- MIG (heavy) – MIG on heavy metals
- PAC – Plasma Arc Cutting
- MIG (light) – MIG on light alloys
- PAW – Plasma Arc Welding
- TIG, GTAG – Tungsten Arc Welding (GTAW, TIG)

TROUBLESHOOTING

1. Not Darkening – Auto lens stays light and will not darken when welding. **Stop welding immediately:** Review the sensitivity recommendations and adjust sensitivity. Clean lens cover and sensors of any obstructions. **Note:** Make sure the sensors are clean and facing the arc; angles of 45° or more will not allow the arc light to reach the sensors.
2. Not Lightening – Auto lens stays dark after the weld arc is extinguished, or the auto-lens stays dark when no arc is present. Fine-tune the sensitivity setting by making small adjustments to the control by turning it toward the 'LO' setting. In extreme light conditions, it may be necessary to reduce the surrounding light levels.
3. During test or use or in case of any malfunction, stop use immediately.

CARE AND MAINTENANCE:

1. The filter lens should be cleaned when the inner or outer cover lenses are replaced.
2. Use only clean water with a clean cloth or paper towel to clean your helmet. **DO NOT APPLY WATER DIRECTLY TO THE FILTER LENS. DO NOT USE ALCOHOL OR OTHER CLEANERS TO CLEAN.**
3. Wipe with clean, dry cloth.
4. Use genuine ATD replacement parts only.

CERTIFICATION:

The welding filters are tested for eye protection by the following notified body: DIN Prüf-und Zertifizierungsstelle für Augenschutz, Alboinstr. 56, D-12103 Berlin, notified body 0196, that provides approval and continual quality system under the control of the European Commission, the German Ministry for Work and the Central Office of the Provinces.

We are therefore allowed to use the following marks:



European conformity mark (fulfils the requirement of the directive 89/686/EWG).



ATD-3715 ATD-3716

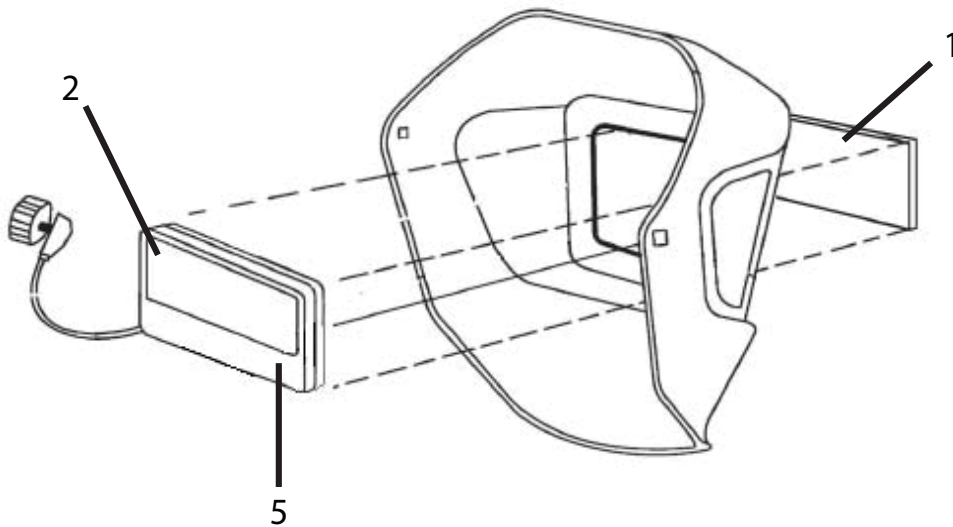
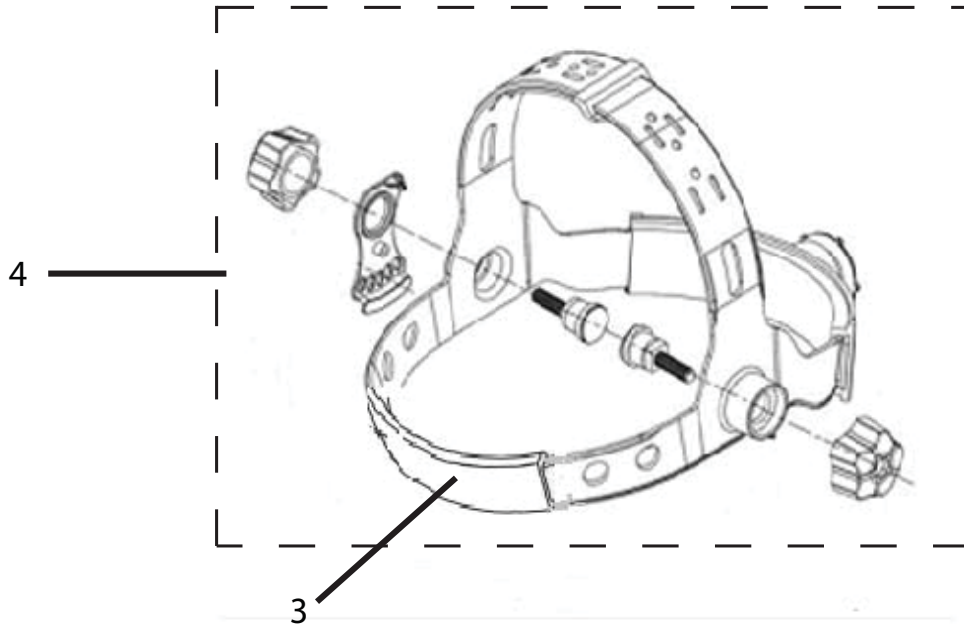

ITEM#	ORDERING PART#	PART DESCRIPTION
1	PRT3715-01	OUTER PROTECTIVE LENS
2	PRT3715-02	INNER PROTECTIVE LENS
3	PRT3715-03	SWEAT BAND
4	PRT3715-04	HEADGEAR ASSEMBLY (Includes headgear, screws, washers & sweat band)
5	PRT3715-05	AUTO DARKENING LENS