



Owner's Manual

Engine Crane

Model Number
ATD-10141

Capacity
2 Ton

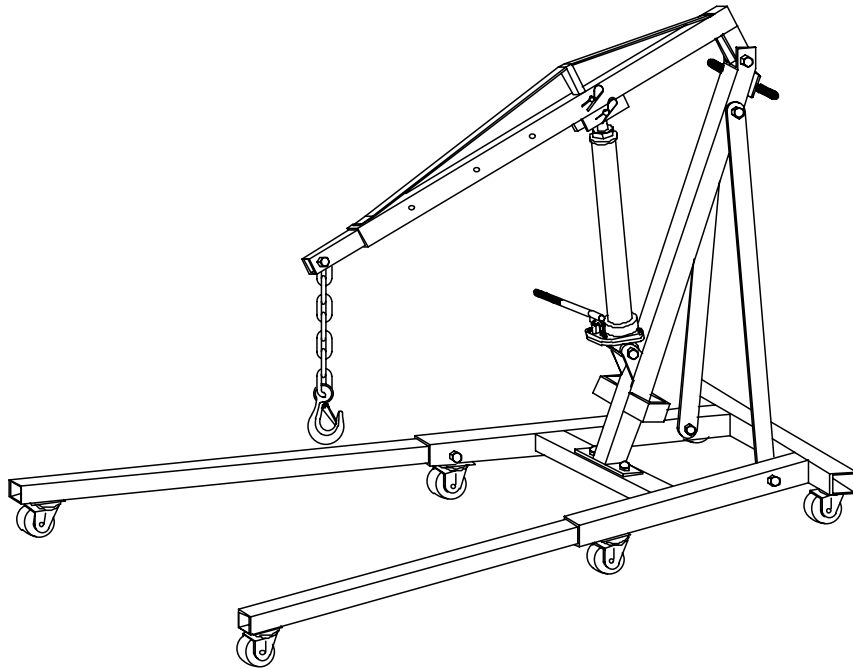

Atd Tools Inc.
160 Enterprise Drive, Wentzville, MO 63385

Printed in China
RHO10141-M1 rev 05/08

Save these instructions. For your safety, read, understand, and follow the information provided with and on this jack. The owner and operator of this equipment shall have an understanding of this engine crane and safe operating procedures before attempting to use. The owner and operator shall be aware that use and repair of this product may require special skills and knowledge. Instructions and safety information shall be conveyed in the operator's native language before use of this jack is authorized. If any doubt exists as to the safe and proper use of this product, remove from service immediately. **Inspect before each use.** Do not use if broken, bent, cracked or damaged parts are noted. Any crane that appears damaged in any way, or operates abnormally shall be removed from service immediately. If the engine crane has been or suspected to have been subjected to a shock load (a load dropped suddenly, unexpectedly), immediately discontinue use until product has been checked by an authorized service center. It is recommended that an annual inspection be done by qualified personnel. Labels and Owners Manuals are available from manufacturer.

PRODUCT DESCRIPTION

ATD Engine Crane is designed to safely lift and lower rated capacity engines. Welded steel tube construction, heavy duty chain and safety hook, steel casters and wheels ensure safety, strength and stability.

SPECIFICATIONS

Model	Boom Position	Capacity	Min. Hook Height	Max. Hook Height	Boom Length
ATD-10141	1	2 Ton	18-1/2"	77-1/4"	52 3/4"
	2	1 1/2 Ton	14-1/8"	80-3/4"	59-1/2"
	3	1 Ton	10"	84-1/2"	66-1/8"
	4	1/2 Ton	5-7/8"	88-1/4"	72-7/8"

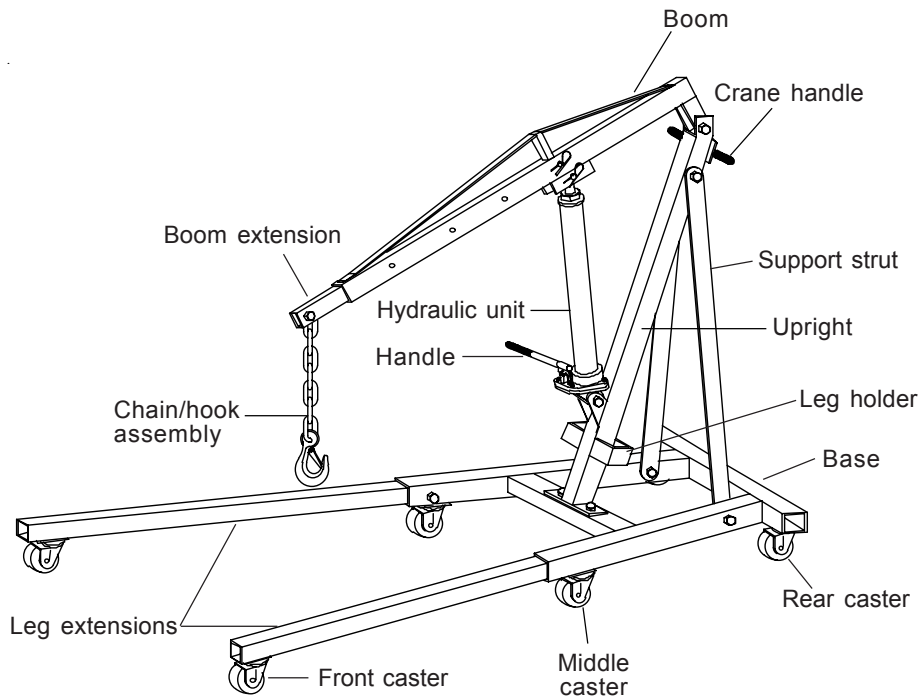

Figure 1 - Engine Crane Nomenclature

ASSEMBLY

1. Attach two front casters (#1) to legs (#3) with M8x12 bolts (#2).
2. Attach two middle casters (#6) and two rear casters (#1) to base (#4) with M8x12 bolts (#2).
3. Slide two legs (#3) into the base (#4) and secure with M14x30 bolts (#8).
4. Attach upright (#7) to base (#4) with M14x100 bolts (#9), washers (#10) and nuts (#11).
5. Attach two strut supports (#12) to base (#4) and upright (#7) with M16x100 bolts (#13), washers (#14), and nuts (#15).
6. Place hydraulic unit (#16) on upright's support bracket and secure with M16 x 90 bolt (#17), washer (#18) and nut (#19).
7. Attach boom (#20) to upright (#7) with M20x100 bolt (#21), washer (#22), and nut (#23).
8. Pump jack until ram is extended approximately 2".
9. Align the hole on the hydraulic ram with the mounting hole of boom and secure with the lock pin (#24) and retainer clip (#25).
10. Slide boom extension (#26) into boom (#20) and secure with the lock pin (#24) and retainer clip (#25).
11. Attach chain/hook assembly (#30) to boom extension (#26) with M14x80 bolt (#27), washer (#28) and nut (#29).
12. Attach handle to upright with four M8x12 bolts (#31).

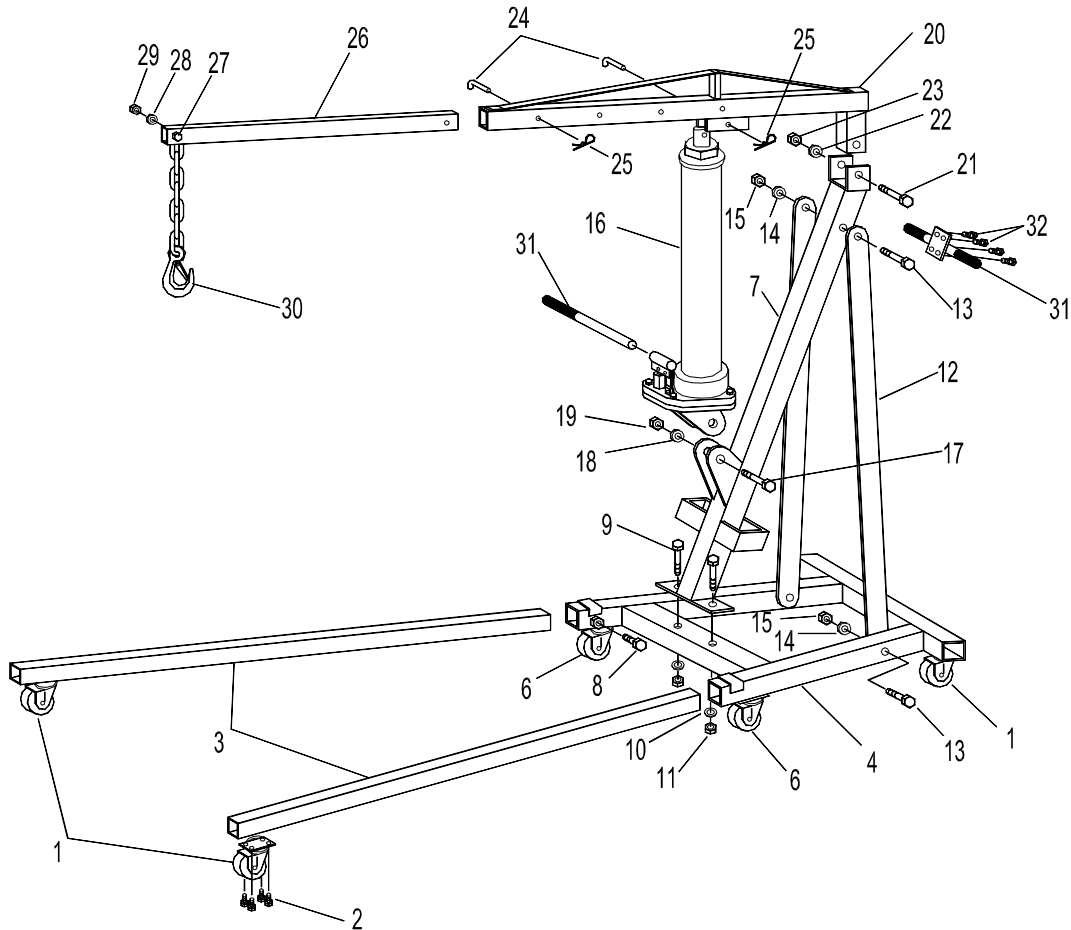

Figure 2 - Assembly Illustration for Model ATD-10141

BEFORE USE

1. Inspect crane before each use. Do not use if bent, broken or cracked components are noted. Ensure that casters/wheels and boom move freely. Check for and tighten any loose assemblies.
2. Verify that the product and the application are compatible.
3. Before using this product, read the owner's manual completely and familiarize yourself thoroughly with the product and the hazards associated with its improper use.

WARNING

- Study, understand, and follow all instructions provided with and on this device before operating this device.
- Do not exceed rated capacity for each boom position.
- Use the device only on a hard, level surface.
- These engine cranes are intended to be used to lift and lower rated capacity automotive and light truck engines. It is an aid in the removal and installation of automotive and light truck engines.
- Only use chains and slings with a capacity equal to or greater than that of the crane.
- If loaded crane must be moved, make certain that load is stable, is in lowest possible position and is moved over a smooth, hard level surface.
- Avoid shock loads caused by the rapid opening and closing of release valve.
- Shock loads may cause the load to swing, causing the crane to flip violently, bend or break.
- Ensure the boom is fully lowered before checking or adding fluid to the hydraulic unit.
- Never extend boom extension beyond furthest distance of leg extension.
- Do not stand over loaded boom nor in its intended line of travel.
- Do not use adapters or accessories that are not provided initially.
- Do not use the device for any purpose other than that for which it is intended.
- Do not modify this device.
- Failure to heed these markings may result in personal injury and/or property damage.

OPERATION

! SAFETY MESSAGE !

- Lift only on areas of the engine as specified by the vehicle manufacturer.
- Be sure all tools and personnel are clear before lowering load.

1. Load capacity should be coordinated with boom extension and legs extension. Do not extend boom extension beyond the marking that coordinate with the legs extension.
2. Ensure application is compatible with product.
3. Secure engine to chain/sling hook assembly, ensuring load is centered.
4. Follow vehicle service manual recommendations to remove engine. When ready to remove engine, turn release valve clockwise until firm. Pump handle until load is high enough to clear vehicle.
5. Immediately upon removal and when clear of the vehicle, lower the load to the lowest practical position by turning the release valve lever counter-clockwise slowly and carefully.

Note: Avoid rolling the loaded engine crane. To help position an engine stand if necessary, move only across smooth, level, seamless surfaces.

Before moving ensure the load:

- a. is lowered to the lowest practical position, but always below the center of gravity.
 - b. is prevented from swinging and inadvertent shifting.
5. Position a suitable engine stand near the removed engine, then immediately transfer the load to appropriate engine support device (engine stand).
 6. Check to ensure stand is secure before working on or around.

WARNING



To avoid crushing and related injuries:
NEVER work on, under or around a load supported only by a crane.
Immediately transfer the load to an appropriately rated engine stand.

MAINTENANCE

Important: Use only a good grade hydraulic jack oil. Avoid mixing different types of fluid and NEVER use brake fluid, turbine oil, transmission fluid, motor oil or glycerin. Improper fluid can cause failure of the jack and the potential for sudden and immediate loss of load. We recommend Mobil 13M or equivalent.

Adding oil

1. Carefully remove hydraulic jack from crane.
2. With ram fully lowered and pump piston fully depressed, set jack in its upright, level position. Remove oil filler plug.
3. Fill with oil until just below the rim of the oil filler plug hole. Reinstall the oil filler plug.

Changing oil

For best performance and longest life, replace the complete fluid supply annually.

1. Carefully remove hydraulic jack from crane.
2. With ram fully lowered and pump piston fully depressed, set jack in its upright, level position. Remove oil filler plug.
3. Lay the jack on its side and drain the fluid into a suitable container.

Note: Dispose of hydraulic fluid in accordance with local regulations.

4. Set jack in its level upright position.
5. Fill with oil until just below the rim of the oil filler plug hole. Reinstall the oil filler plug.

Lubrication

A periodic coating of light lubricating oil to pivot points, axles and hinges will help to prevent rust and assure that wheels, casters, and pump assemblies move freely.

Cleaning

Periodically check the pump piston and ram for signs of rust or corrosion. Clean as needed and wipe with an oily cloth.

Note: Never use sandpaper or abrasive material on these surfaces !

Storage

1. When not in use, store the jack with pump piston and ram fully retracted.
2. To transform the crane into storage position:
 - a. Remove lock pin (#24 on figure 2) from boom.
 - b. Lean hydraulic unit back against upright and slowly lower the boom to rest against hydraulic unit.
 - c. Remove bolts (#8 on figure 2) of left and right legs of the crane.
 - d. Remove legs from crane and keep it in the leg holder at each side of upright.

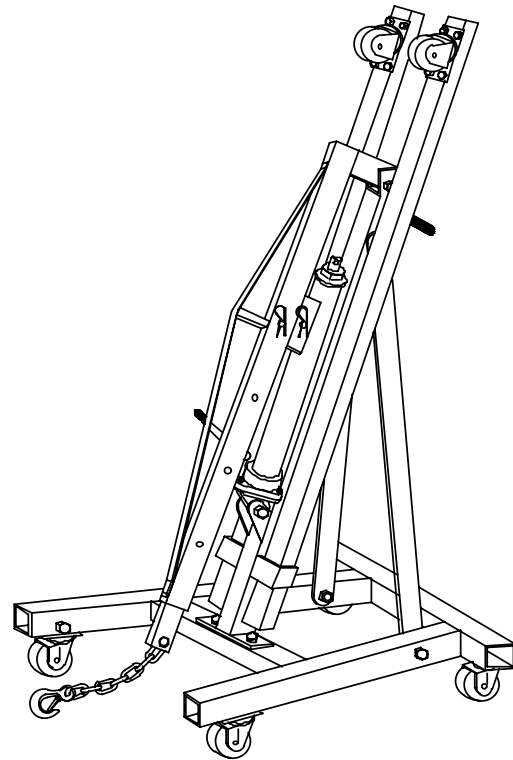

Figure 3 - Engine Crane Storage Position

TROUBLESHOOTING

Symptom	Possible Causes	Corrective Action
Jack will not lift load	<ul style="list-style-type: none"> • Release valve not tightly closed • Overload condition 	<ul style="list-style-type: none"> • Ensure release valve tightly closed • Remedy overload condition
Jack *bleeds off after lift	<ul style="list-style-type: none"> • Release valve not tightly closed • Overload condition • Hydraulic unit malfunction 	<ul style="list-style-type: none"> • Ensure release valve tightly closed • Remedy overload condition • Replace hydraulic unit
Jack will not lower after unloading	<ul style="list-style-type: none"> • Reservoir overfilled 	<ul style="list-style-type: none"> • Drain fluid to proper level
Poor lift performance	<ul style="list-style-type: none"> • Fluid level low • Air trapped in system 	<ul style="list-style-type: none"> • Ensure proper fluid level • With ram fully retracted, remove oil filler plug to let pressurized air escape, then reinstall oil filler plug.
Jack will not lift to full extension	<ul style="list-style-type: none"> • Fluid level low 	<ul style="list-style-type: none"> • Ensure proper fluid level

* "Bleeding off" means that jack begins to slowly lower rather than keep load at height.

REPLACEMENT PARTS

Not all components of the crane are replacement items, but are illustrated as a convenient reference of location and position in the assembly sequence. When ordering parts, give the model number, serial number and parts description.

Model ATD-10141

<u>Item</u>	<u>Description</u>	<u>Quantity</u>
01	Boom	1
02	Boom extension	1
03	Chain and hook assembly	1
04	Crane Handle	1
05	Support strut	2
06	Upright	1
07	Base	1
08	Leg	2
09	Middle caster	2
10	Rear caster	2
11	Front caster	2
12	Hydraulic unit	1
-	Hardware kit	all bolts & nuts
-	Label(s)	-
-	Manual	-

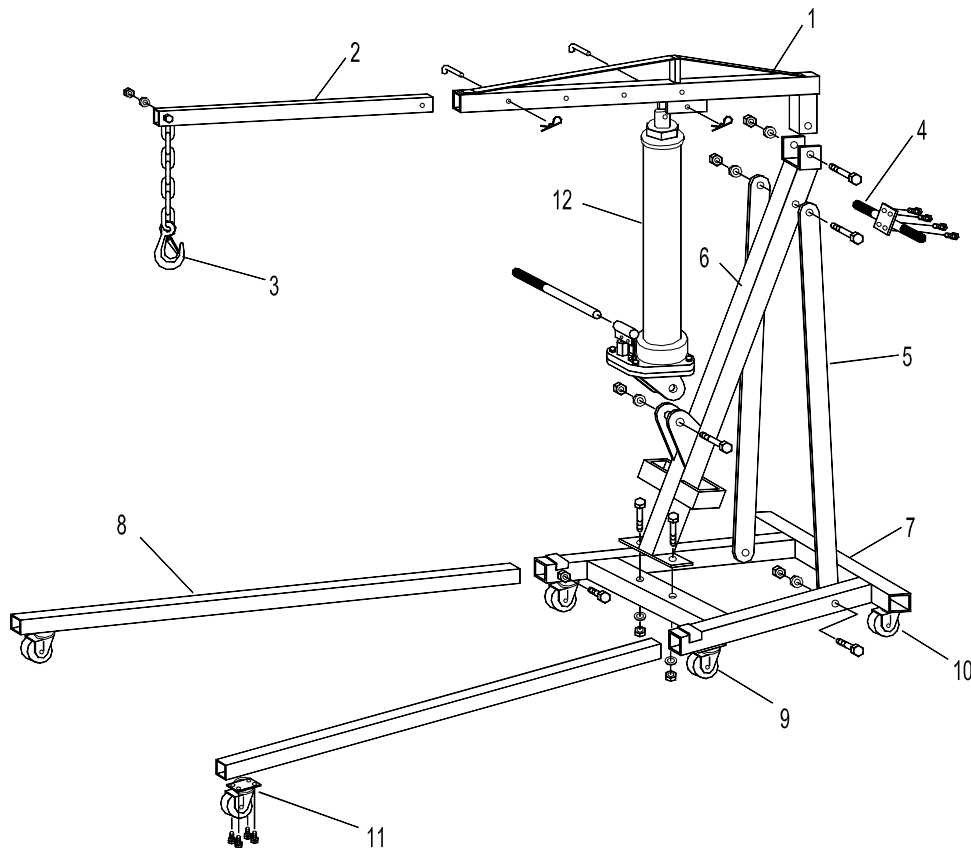

Figure 4 - Replacement Parts Illustration for Model ATD-10141

ONE YEAR LIMITED WARRANTY

For a period of one (1) year from date of purchase, **Atd Tools Inc.** will repair or replace, at its option, without charge, any of its products which fails due to a defect in material or workmanship, or which fails to conform to any implied warranty not excluded hereby.

Performance of any obligation under this warranty may be obtained by contacting your point of sale and obtaining return or repair information from your supplier.

Except where such limitations and exclusions are specifically prohibited by applicable law, (1) the CONSUMER'S SOLE AND EXCLUSIVE REMEDY SHALL BE THE REPAIR OR REPLACEMENT OF DEFECTIVE PRODUCTS AS DESCRIBED ABOVE, and (2) **Atd Tools Inc.** SHALL NOT BE LIABLE FOR ANY CONSEQUENTIAL OR INCIDENTAL DAMAGE OR LOSS WHATSOEVER, and (3) THE DURATION OF ANY AND ALL EXPRESSED AND IMPLIED WARRANTIES, INCLUDING WITHOUT LIMITATION, ANY WARRANTIES OF MERCHANTABILITY AND FITNESS FOR A PARTICULAR PURPOSE, IS LIMITED TO A PERIOD OF ONE (1) YEAR FROM DATE OF PURCHASE.

Some states do not allow limitations on how long an implied warranty lasts, so the above limitation may not apply to you. Some states do not allow the exclusion or limitation of incidental or consequential damages, so the above limitation or exclusion may not apply to you. This warranty gives you specific legal rights, and you may also have other rights which vary from state to state.



Atd Tools Inc.
160 Enterprise Drive,
Wentzville MO 63385
636-327-9050